

DOBBELTVIRKENDE SYLINDER

Type KMI-DVLG

Sfærisk opplagring/Gjenget stempelstang

Trykk 220 bar

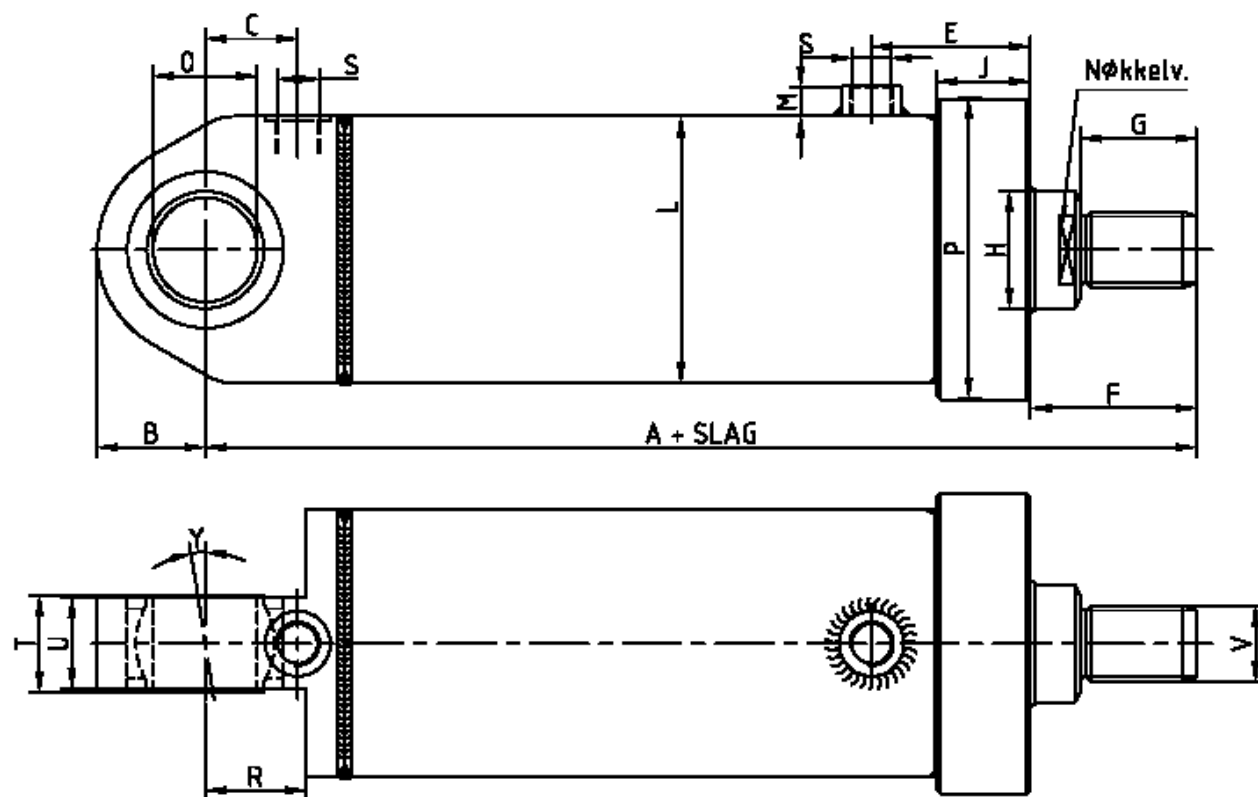

Mål i mm

Syl. Ø	50			65			80		90		100		
Stang Ø	25	30	35	30	35	40	40	50	45	60	50	60	70
A	193			209			231		255		265		
B	30			35			40		50		53		
C	27			28			30		38		38		
E	62			67			62		70		72		
F	45			50			65		70		78		
G	25			30			40		45		48		
H	ø25	ø30	ø35	ø30	ø35	ø40	ø40	ø50	ø45	ø60	ø50	ø60	ø70
J	43			43			37		-		47		
L	ø60			ø75			ø90		ø105		ø115		
M	14			14			19		19		19		
O	ø25(-0.01)			ø30(-0.01)			ø35(-0.01)		ø45(-0.01)		ø50(-0.012)		
P	ø70			ø85			ø100		ø105		ø130		
R	30			33			39		44		47		
S	3/8"RG			3/8"RG			1/2"RG		1/2"RG		3/4"RG		
T	29			30			35		40		43		
U	24			28			32		38		40		
V	M20x1.5			M27x2			M33x2		M33x2		M42x2		
Y	3°			3°			3°		3°		3°		
NV.	19	24	29	24	29	32	32	41	36	55	41	55	60

Forbehold om trykkfeil og rett til endring av mål.

DOBBELTVIRKENDE SYLINDER



Type KMI-DVLG

Sfærisk opplagring/Gjenget stempelstang

Trykk 220 bar

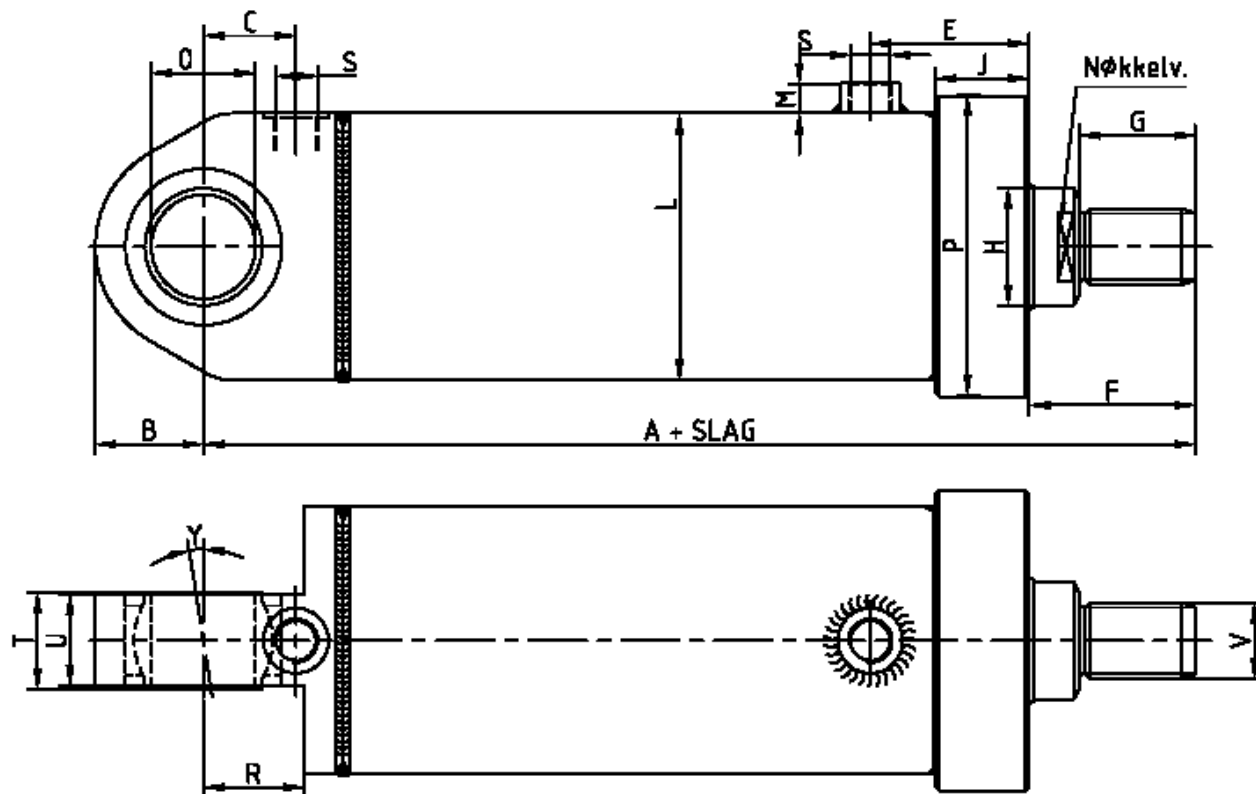

Mål i mm

Syl. Ø	125			140		160		180		200	
Stang Ø	60	70	80	70	80	80	90	90	100	100	125
A	319			354		398		432		458	
B	65			73		80		83		90	
C	49			60		62		71		81	
E	82			99.5		114		122		122	
F	95			100		120		125		140	
G	65			70		85		90		105	
H	ø60	ø70	ø80	ø70	ø80	ø80	ø90	ø90	ø100	ø100	ø125
J	52			65		65		72		72	
L	ø145			ø160		ø180		ø205		ø225	
M	19			19		24		24		24	
O	ø60(-0.015)			ø70(-0.015)		ø80(-0.015)		ø80(-0.015)		ø90(-0.02)	
P	ø169			ø190		ø210		ø230		ø250	
R	54			68		75		77		85	
S	3/4"RG			3/4"RG		1"RG		1"RG		1"RG	
T	54			65		74		74		60	
U	50			60		70		70		80	
V	M48x2			M56x2		M64x3		M64x3		M72x3	
Y	3°			3°		3°		3°		4°	
NV.	55	60	70	60	70	70	80	80	90	90	100

Forbehold om trykkfeil og rett til endring av mål.