



# SUBMERSIBLE PUMPS





## PRORIL

PRORIL was established in 1979, starting from a small motor factory where it has transformed itself into a global size submersible pump manufacturer. Its perseverance and dedication of making high quality products and maintaining a strong working etiquette are mere images of the founder's belief and philosophy that contribute to the success of PRORIL.

PRORIL specializes in submersible pump manufacturing service, and continues investing in the fluid dynamics design, motor efficiency enhancement, and R&D of various metal alloys. The integration of upstream and downstream suppliers has completed the manufacturing chain that PRORIL proudly offers to its customers. PRORIL goes through stringent quality procedures where its quality management system conforms to the global standards.

Today, PRORIL has developed a complete product line that covers dewatering pumps, sewage pumps, slurry pumps, and others. They are applicable in general drainage, construction, industrial sites, wastewater treatment, sludge removal, and so on. Furthermore, PRORIL's professional R&D team continuously improves the product performance to meet various needs in tough dewatering applications.

PRORIL Pumps Europe is based in the Netherlands and carries an extensive stock of pumps and parts which is complemented by a modern workshop and testing facilities. Decades of pump experience ensures that you will receive the best service possible.



# CONTENTS

## DEWATERING PUMPS

6 - 15



<b>TANK</b>	215 315	10
	222 322 422	10
	237 337 437	11
	355 455	11
	475 675	11
	3110 4110 6110	12
	4150 6150	12
	4220 6220 8220	12
<b>TANK</b>	6370 8370	13
	6450 8450	13
<b>TANK SLIM</b>	230 330	15
	380	15

## SLURRY & SAND PUMPS

16 - 23



<b>STORMY</b>	337 437	20
	355 455	20
	475	22
	4110 6110	22
	6150 6150L	22
	6220 8220	22

## SEWAGE PUMPS

24 - 35



<b>GOCUT</b>	208	28
	215 315	28
	322 337 437	28
<b>GOMAX</b>	337 437	30
	455 655	30
	475 675	30
	4110 6110	31
	4150 6150	31
	4220 6220	31
<b>GOVOX</b>	204	32
	208 315	32
<b>GOVOX-G</b>	322 337 437	32
	455 475	33
<b>GOVOX-U</b>	322 337	33
	455 475	33
<b>GOVOX-S</b>	322 337	33
<b>GUIDE RAIL SYSTEM</b>		34

## HANDY & RESIDUE PUMPS

36 - 45



<b>SMART</b>	400 750	39
	1500	39
<b>SMART BASE</b>	400	39
<b>SMART LITE</b>	400	40
	750	40
<b>SMART LITE BASE</b>	400	41
<b>SAVVY</b>	150	43
	300 600	44
<b>SAVVY JUMBO</b>	300 600	44
<b>SAVVY BASE</b>	300 600	44

## STAINLESS STEEL PUMPS

46 - 49



<b>X-SMART</b>	400 750	49
	215 315	49
<b>X-VOX</b>	208 215	49

## ACCESSORIES

50 - 51



<b>PROTECTOR PLUGS</b>	50
<b>FLOAT SWITCH</b>	50
<b>GUIDE RAIL SYSTEM</b>	51

## TECHNICAL INFORMATION

52 - 55

<b>INSTALLATION</b>	52
<b>FRICTION LOSS CALCULATION</b>	53
<b>CONVERSION CHARTS</b>	54
<b>IMPELLER TYPES</b>	55

# DEWATERING PUMPS

Our dewatering pumps are engineered for professional use in tough dewatering applications in construction, industrial sites, and mines. With a compact, slim design and our patented ACrS technology, these wear-resistant portable dewatering pumps provide economical solutions.



# TANK SERIES

## HIGH CHROME DEWATERING PUMP

Designed for continuous operations, excellent performance and easy maintenance, PRORIL Tank series pumps have proven their reliability and durability in demanding areas like construction, mining, tunneling, quarries, industries and rental applications.

### FEATURES

#### 1 Watertight Cable Entry

The cable entry employs an anti-wicking block where each conductor is stripped and encapsulated in epoxy. This feature effectively prevents water from penetrating the motor chamber when the cable end is submerged or the cable sheath is damaged.

#### 2 Multi-Direction BSP Discharge Coupling

Discharge can be converted between vertical and horizontal directions. In pumps 7,5 kW and larger, a vertical discharge connection is supplied as standard.

#### 3 Motor Protector

The motor incorporates a circle thermal protector which protects against overheating and dry-run.

#### 4 Top Discharge and Double Housing Design

Designed to construct a water jacket that provides maximum motor cooling effect for continuous operation at low water level, this feature forms the cylindrical and slim shape of the pump and enables the pump to be installed in confined spaces.

#### 5 Submersible Motor

Air filled motor, housed in a watertight casing, conforms to Class F insulation.

#### 6 C3 Ball Bearings and Hardened SS Shaft

High quality of C3 ball bearings and the well-balanced, hardened stainless steel shaft enhance stability during continuous pumping operations.

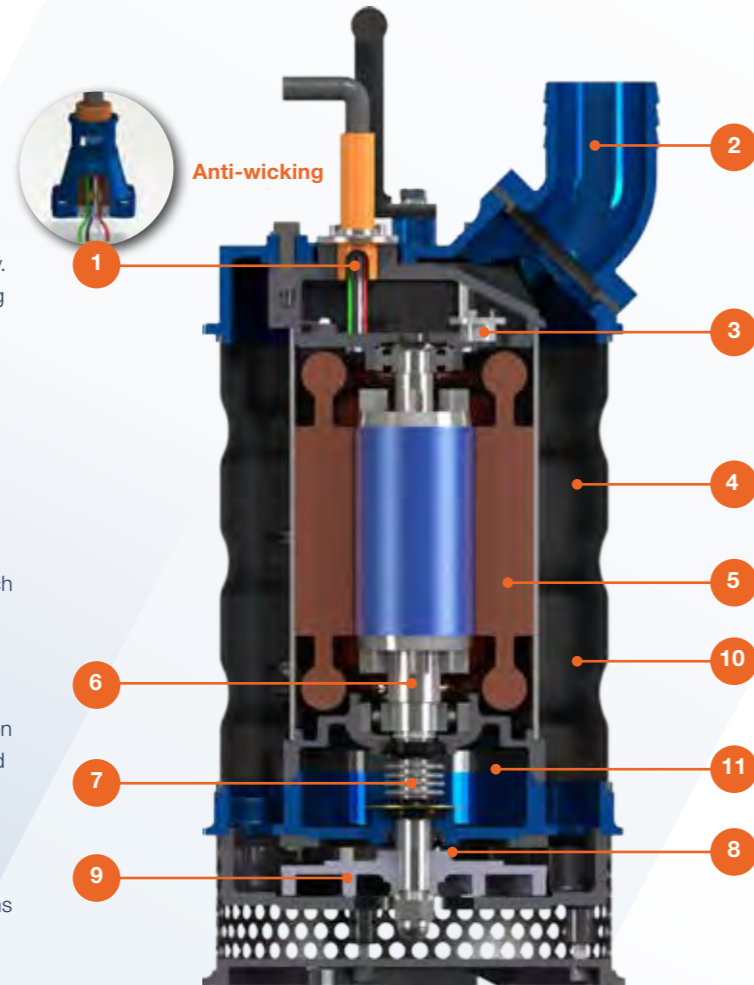

#### 7 EagleBurgmann® Double Mechanical Seals

Located in the oil chamber, the device is made of quality materials with highly wear-resistant silicon carbide in lower side that provides extra protection against leakage and dry-run.

#### 8 Extra Protection for Mechanical Seals and Shaft

Lip seals and shaft sleeves are utilized for additional protection against wear.

#### 9 High Chrome Steel Impeller

PRORIL patent formula, ACrS Tech is applied to all high chrome steel impellers. This technology increases wear resistance to particle abrasion.

#### 10 Durable Outer Jacket and Strainer

Corrugated Outer Jacket and strainer made from 304 stainless steel provide impact resistance to harsh handling and conditions. In pumps 7,5 kW and larger, flat 304 stainless steel outer casing is provided as standard.

#### 11 Food Grade Lubricant

PRORIL adopts eco-friendly lubricant to minimize environmental impacts.



### Advanced Chromium Steel Tech Material

Designed for high wear resistance and superb corrosion resistance, ACrS Tech is applied to all our TANK series impellers to tackle tough challenging applications. The use of ACrS Tech chromium steel material significantly reduces operational costs.



### Heavy Duty PUR Cable

As rugged as our pumps. Provides an ultra-solid solution to the weak spot of every submersible pump. Increases safety on the construction site with maximum visibility.



### Adjustable BSP Discharge Coupling

The discharge coupling can be adjusted to vertical or horizontal directions. In 7,5 kW and larger pumps, a vertical discharge connection is standard.



### Watertight Cable Entry

The cable entry features an anti-wicking block where each conductor is stripped and encased in epoxy. In doing so, water is effectively prevented from entering the motor chamber when the cable end is submerged or should the cable sheath become damaged.

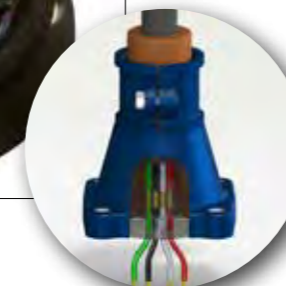



**TANK 237 337 437**



TANK	237	337	437
Outlet	2" (BSP)	3" (BSP)	4" (BSP)
Rated Output	3.7 kW	3.7 kW	3.7 kW
Shaft Speed	2850 rpm	2850 rpm	2850 rpm
Solid Passage	10 mm	10 mm	10 mm
Height	625 mm	630 mm	630 mm
Diameter	Ø 291 mm	Ø 269 mm	Ø 284 mm
Weight	61 kg	42 kg	42 kg

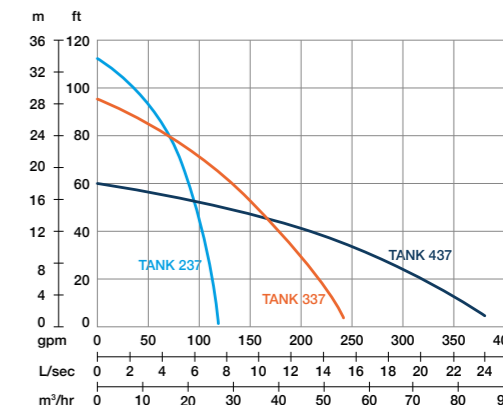

**TANK 215 315**



TANK	215	315
Outlet	2" (BSP)	3" (BSP)
Rated Output	1.5 kW	1.5 kW
Shaft Speed	2850 rpm	2850 rpm
Solid Passage	9 mm	9 mm
Height	568 mm	568 mm
Diameter	Ø 253 mm	Ø 267 mm
Weight	33 kg	33 kg

Also available in 230 Volt (S)

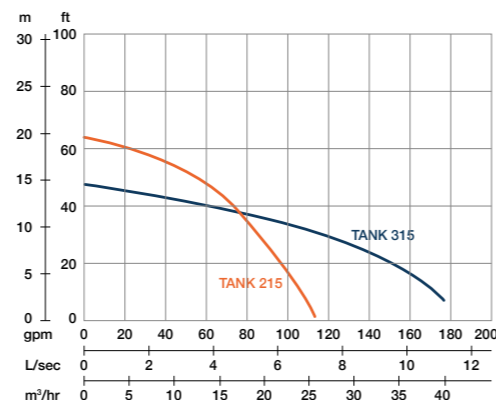

**TANK 355 455**



TANK	355	455
Outlet	3" (BSP)	4" (BSP)
Rated Output	5.5 kW	5.5 kW
Shaft Speed	2850 rpm	2850 rpm
Solid Passage	10 mm	10 mm
Height	656 mm	656 mm
Diameter	Ø 306 mm	Ø 320 mm
Weight	60 kg	60 kg

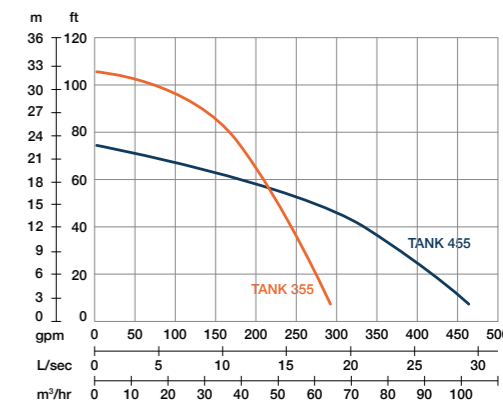

**TANK 222 322 422**



TANK	222	322	422
Outlet	2" (BSP)	3" (BSP)	4" (BSP)
Rated Output	2.2 kW	2.2 kW	2.2 kW
Shaft Speed	2850 rpm	2850 rpm	2850 rpm
Solid Passage	9 mm	9 mm	9 mm
Height	598 mm	598 mm	630 mm
Diameter	Ø 253 mm	Ø 267 mm	Ø 284 mm
Weight	35 kg	35 kg	43 kg

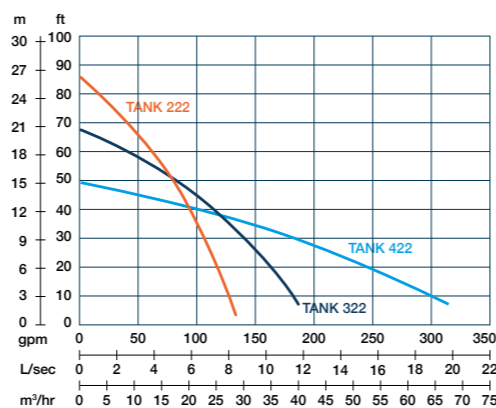

**TANK 475 675**



TANK	475	675
Outlet	4" (BSP)	6" (BSP)
Rated Output	7.5 kW	7.5 kW
Shaft Speed	2850 rpm	2850 rpm
Solid Passage	15 mm	15 mm
Height	801 mm	826 mm
Diameter	Ø 317 mm	Ø 317 mm
Weight	93 kg	97 kg

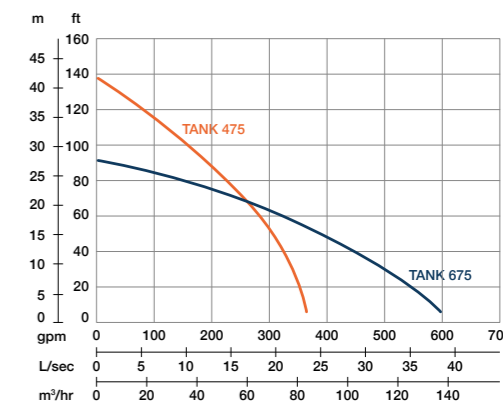

**TANK** | 3110 4110 6110



TANK	3110	4110	6110
Outlet	3" (BSP)	4" (BSP)	6" (BSP)
Rated Output	11 kW	11 kW	11 kW
Shaft Speed	2850 rpm	2850 rpm	2850 rpm
Solid Passage	12 mm	15 mm	15 mm
Height	863 mm	858 mm	870 mm
Diameter	Ø 354 mm	Ø 354 mm	Ø 354 mm
Weight	135 kg	135 kg	137 kg

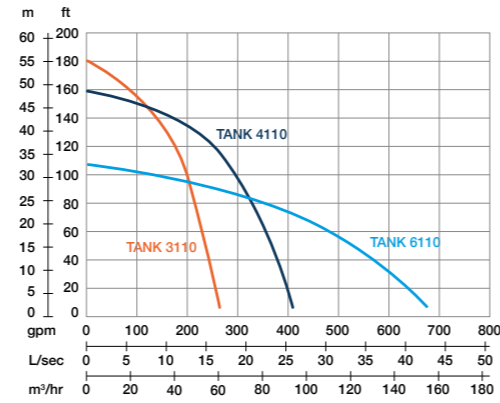

**TANK** | 6370 8370



TANK	6370	8370
Outlet	6" (BSP)	8" (BSP)
Rated Output	37 kW	37 kW
Shaft Speed	2850 rpm	2850 rpm
Solid Passage	10 mm	20 mm
Height	1294 mm	1256 mm
Diameter	Ø 532 mm	Ø 532 mm
Weight	510 kg	510 kg

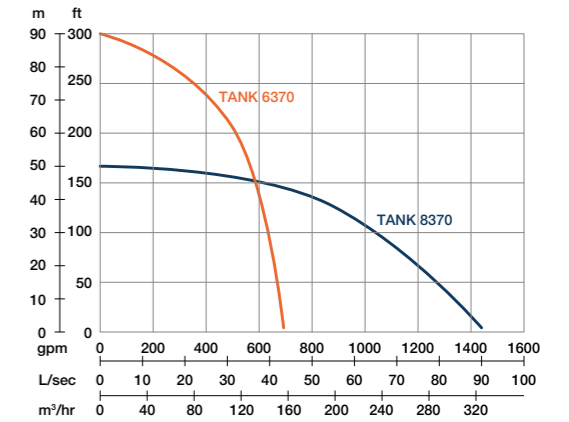

**TANK** | 4150 6150



TANK	4150	6150
Outlet	4" (BSP)	6" (BSP)
Rated Output	15 kW	15 kW
Shaft Speed	2850 rpm	2850 rpm
Solid Passage	15 mm	15 mm
Height	887 mm	899 mm
Diameter	Ø 354 mm	Ø 354 mm
Weight	141 kg	142 kg

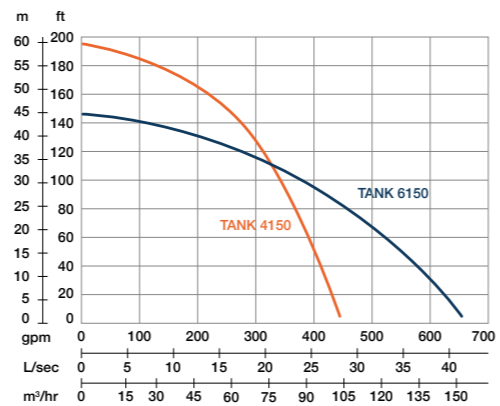

**TANK** | 6450 8450



TANK	6450	8450
Outlet	6" (BSP)	8" (BSP)
Rated Output	45 kW	45 kW
Shaft Speed	2850 rpm	2850 rpm
Solid Passage	10 mm	20 mm
Height	1294 mm	1256 mm
Diameter	Ø 532 mm	Ø 532 mm
Weight	530 kg	530 kg

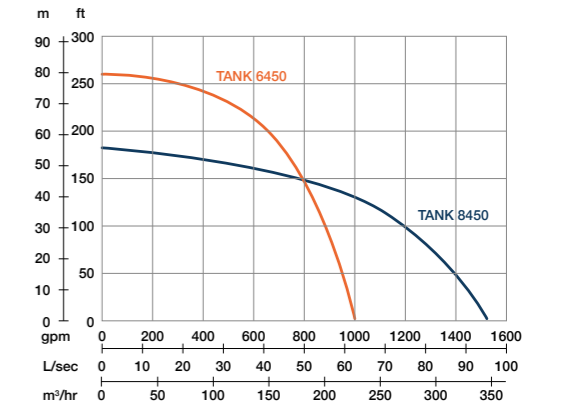

**TANK** | 4220 6220 8220



TANK	4220	6220	8220
Outlet	4" (BSP)	6" (BSP)	8" (BSP)
Rated Output	22 kW	22 kW	22 kW
Shaft Speed	2850 rpm	2850 rpm	2850 rpm
Solid Passage	15 mm	20 mm	20 mm
Height	1085 mm	1099 mm	1154 mm
Diameter	Ø 424 mm	Ø 424 mm	Ø 424 mm
Weight	256 kg	259 kg	264 kg

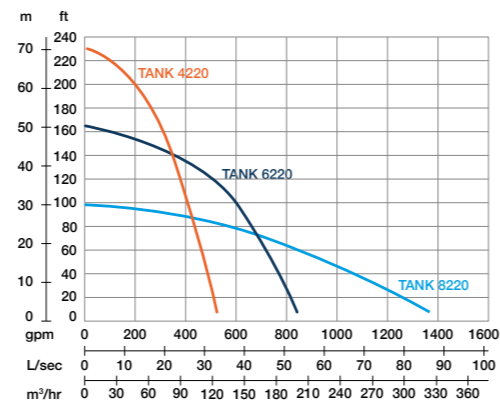



**TANK SLIM | 230 330**



TANK SLIM	230	330
Outlet	2" (BSP)	3" (BSP)
Rated Output	3 kW	3 kW
Shaft Speed	2850 rpm	2850 rpm
Solid Passage	7 mm	7 mm
Height	659 mm	629 mm
Diameter	Ø 188 mm	Ø 188 mm
Weight	45 kg	38 kg

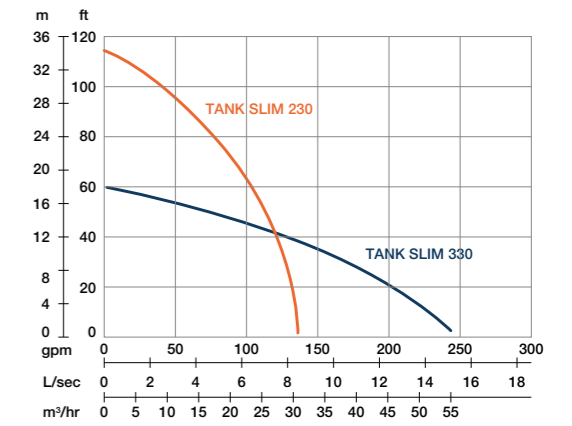

**TANK SLIM | 380**



TANK SLIM	380
Outlet	3" (BSP)
Rated Output	8 kW
Shaft Speed	2850 rpm
Solid Passage	8 mm
Height	798 mm
Diameter	Ø 283 mm
Weight	92 kg

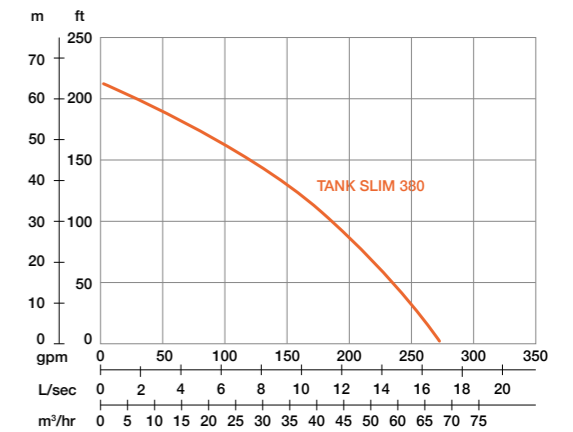



# SLURRY & SAND PUMPS

Serving a wide range of slurry transport applications, PRORIL's slurry pumps are designed for long wear life, low energy consumption, excellent performance, and easy maintenance. With our patented ACrS Tech and rugged construction, these abrasion and corrosion resistant slurry pumps provide economical solutions for challenging slurry transportation.

# STORMY SERIES

## OPEN STAND AND AGITATOR, STRAINER AND AGITATOR

Rugged, reliable and cost effective, the Stormy series pumps come complete with patented high chrome impellers, agitators, and wear plates to withstand tough slurry transportation. STORMY pumps are designed with two different types of pump stands, the open stand and the strainer. Our slurry pumps serve a wide range of slurry transport applications like mining, quarrying, construction sites, and other demanding industries.

### FEATURES

#### 1 Watertight Cable Entry

The cable entry employs an anti-wicking block where each conductor is stripped and encapsulated in epoxy. This feature effectively prevents water from penetrating the motor chamber when the cable end is submerged or the cable sheath is damaged.

#### 2 Top Discharge and Side Flow Design

Designed to cool the motor with pumped water even at low water level, this feature forms the cylindrical and slim shape of the pump and enables the pump to be installed in confined spaces.

#### 3 Motor Protector

The motor incorporates a circle thermal protector which protects against overheating and dry-run.

#### 4 Submersible 4-Pole Motor

Air filled motor, housed in a watertight casing, conforms to Class F insulation. The 4-pole motor helps reducing impeller wears.

#### 5 C3 Ball Bearings and Hardened SS Shaft

High quality of C3 ball bearings and the well-balanced, hardened stainless steel shaft enhance stability during continuous pumping operations.

#### 6 EagleBurgmann® Double Mechanical Seals

Located in the oil chamber, the device is made of quality materials with highly wear-resistant silicon carbide in lower side that provides extra protection against leakage and dry-run.

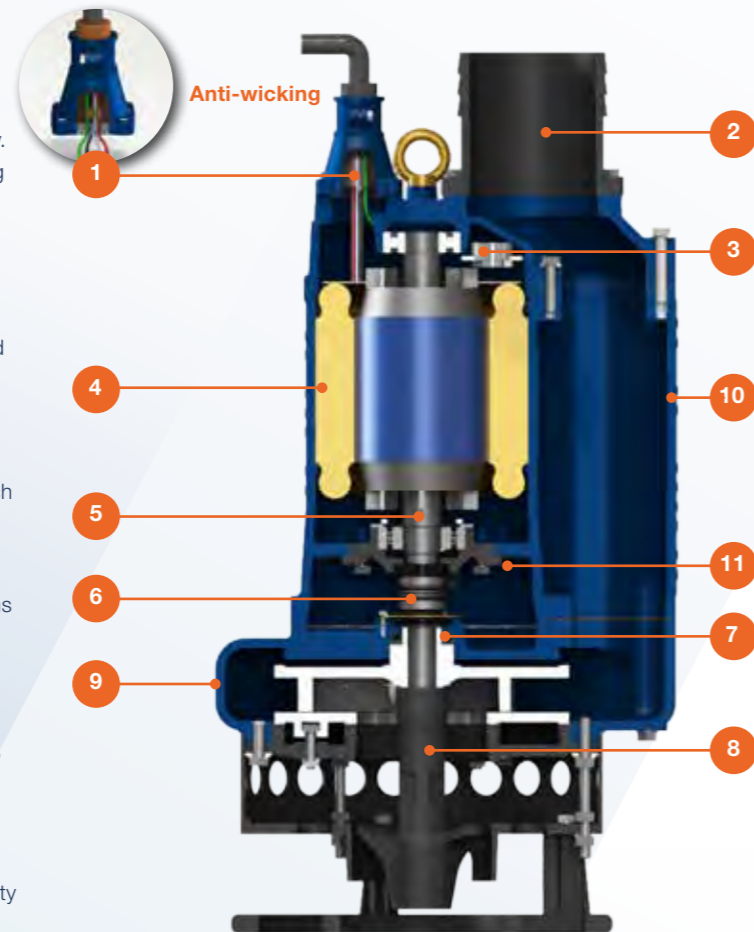

#### 7 Extra Protection for Mechanical Seals and Shaft

Lip seals and shaft sleeves are utilized for additional protection against wear.

#### 8 High Chrome Steel Impeller, Agitator, and Wear plate

PRORIL patent formula, ACRS Tech is applied to all high chrome steel components, including impellers, agitators, and wear plates. This technology increases wear resistance to particle abrasion.

#### 9 Hardened Pump Volute

The pump volute is made from hardened cast ductile iron. This technology enhances the hardness and wear life of the pump casing.

#### 10 Rugged Cast Iron Construction

The whole cast iron pump features a simple, robust structure that provides durability and impact resistance to rough conditions.

#### 11 Food Grade Lubricant

PRORIL adopts eco-friendly lubricant to minimize environmental impacts.



### How the agitator works

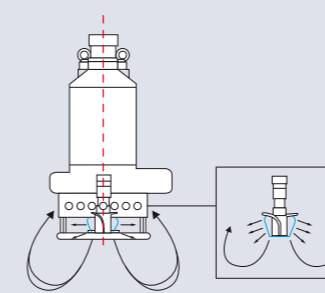

The rigid agitator delivers kinetic energy (energy of motion) to stir solids surrounding the pump intake, re-suspending them into a fluid state for easy pumping.

### Agitator fastening

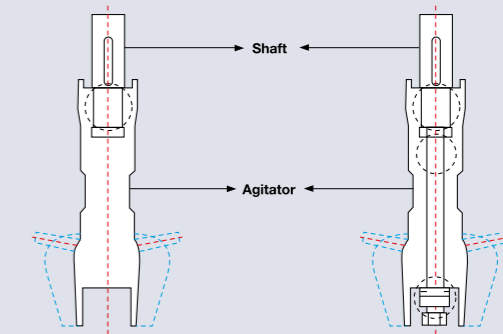

#### Conventional:

The agitator is simply attached onto the end of the pump shaft. As the agitator is only fastened at a single point, the agitator can loosen itself or come off during use.

#### PRORIL Pump's design:

By using a prolonged pump shaft, the agitator is fastened at three separate points, ensuring that the agitator cannot loosen itself.



### High Chrome Steel Impeller, Agitator and Wear plate

Designed for high wear resistance and superb corrosion resistance, ACRS Tech is applied to all our STORMY series impellers, agitators and wear plates to tackle tough challenging applications. The use of ACRS Tech chromium steel material significantly reduces operational costs.



### Heavy Duty PUR Cable

As rugged as our pumps. Provides an ultra solid solution to the weak spot of every submersible pump. Extra safety on the construction site and maximum visibility.



### Watertight Cable Entry

The cable entry employs an anti-wicking block where each conductor is stripped and encapsulated in epoxy. This feature effectively prevents water from penetrating the motor chamber when the cable end is submerged or the cable sheath is damaged.

**STORMY**

**337 437**



Ⓟ

Ⓢ

STORMY	337	437
Outlet	3" (BSP)	4" (BSP)
Rated Output	3.7 kW	3.7 kW
Shaft Speed	1450 rpm	1450 rpm
Solid Passage	25 mm	25 mm
Height Ⓟ	762 mm	783 mm
Height Ⓢ	793 mm	814 mm
Diameter Ⓟ	Ø 385 mm	Ø 385 mm
Diameter Ⓢ	Ø 382 mm	Ø 382 mm
Weight Ⓟ	110 kg	110 kg
Weight Ⓢ	115 kg	115 kg

Ⓟ = open stand Ⓢ = strainer

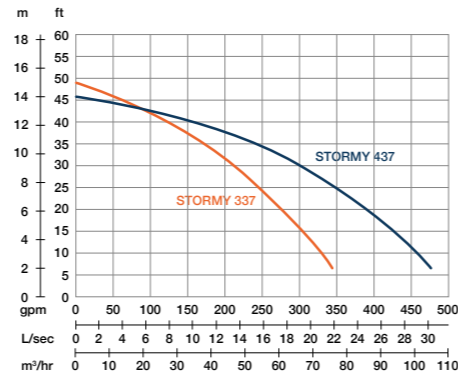

**STORMY**

**355 455**



Ⓟ

Ⓢ

STORMY	355	455
Outlet	3" (BSP)	4" (BSP)
Rated Output	5.5 kW	5.5 kW
Shaft Speed	1450 rpm	1450 rpm
Solid Passage	25 mm	25 mm
Height Ⓟ	806 mm	826 mm
Height Ⓢ	806 mm	826 mm
Diameter Ⓟ	Ø 420 mm	Ø 420 mm
Diameter Ⓢ	Ø 412 mm	Ø 412 mm
Weight Ⓟ	123 kg	124 kg
Weight Ⓢ	131 kg	132 kg

Ⓟ = open stand Ⓢ = strainer

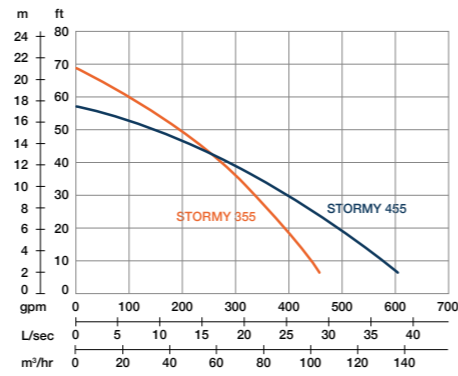

**STORMY 475**



(P) (S)

STORMY 475	
Outlet	4" (BSP)
Rated Output	7.5 kW
Shaft Speed	1450 rpm
Solid Passage	25 mm
Height (P)	826 mm
Height (S)	826 mm
Diameter (P)	Ø 420 mm
Diameter (S)	Ø 412 mm
Weight (P)	124 kg
Weight (S)	132 kg

(P) = open stand (S) = strainer

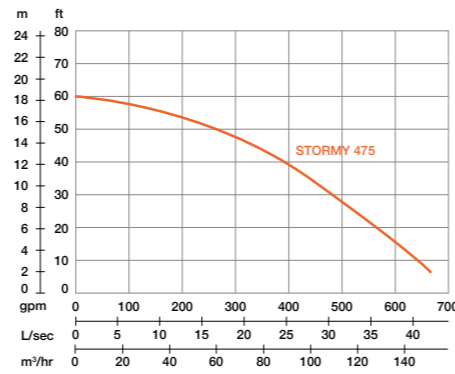

**STORMY 4110 6110**



(P) (S)

STORMY 4110		6110	
Outlet	4" (BSP)	6" (BSP)	6" (BSP)
Rated Output	11 kW	11 kW	11 kW
Shaft Speed	1450 rpm	1450 rpm	1450 rpm
Solid Passage	25 mm	35 mm	35 mm
Height (P)	901 mm	913 mm	913 mm
Height (S)	910 mm	922 mm	922 mm
Diameter (P)	Ø 479 mm	Ø 479 mm	Ø 479 mm
Diameter (S)	Ø 479 mm	Ø 479 mm	Ø 479 mm
Weight (P)	191 kg	192 kg	192 kg
Weight (S)	199 kg	200 kg	200 kg

(P) = open stand (S) = strainer

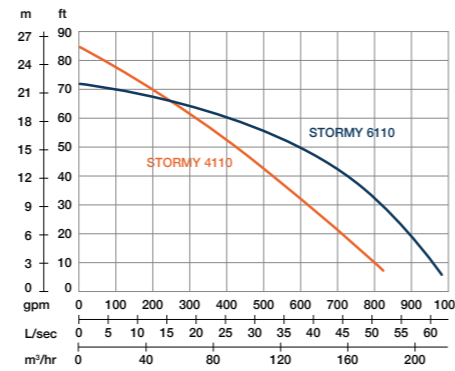

**STORMY 6150 6150L**



(P) (S)

STORMY 6150		6150L	
Outlet	6" (BSP)	6" (BSP)	6" (BSP)
Rated Output	15 kW	15 kW	15 kW
Shaft Speed	1450 rpm	1450 rpm	1450 rpm
Solid Passage	35 mm	35 mm	35 mm
Height (P)	913 mm	913 mm	913 mm
Height (S)	922 mm	922 mm	922 mm
Diameter (P)	Ø 479 mm	Ø 479 mm	Ø 479 mm
Diameter (S)	Ø 479 mm	Ø 479 mm	Ø 479 mm
Weight (P)	201 kg	201 kg	201 kg
Weight (S)	208 kg	208 kg	208 kg

(P) = open stand (S) = strainer

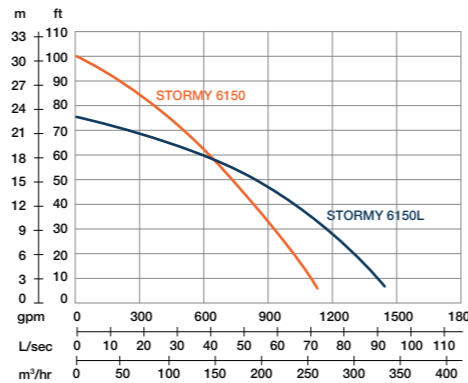

**STORMY 6220 8220**



(P) (S)

STORMY 6220		8220	
Outlet	6" (BSP)	8" (BSP)	8" (BSP)
Rated Output	22 kW	22 kW	22 kW
Shaft Speed	1450 rpm	1450 rpm	1450 rpm
Solid Passage	30 mm	40 mm	40 mm
Height (P)	1204 mm	1166 mm	1166 mm
Height (S)	1210 mm	1172 mm	1172 mm
Diameter (P)	Ø 592 mm	Ø 592 mm	Ø 592 mm
Diameter (S)	Ø 592 mm	Ø 592 mm	Ø 592 mm
Weight (P)	345 kg	355 kg	355 kg
Weight (S)	357 kg	367 kg	367 kg

(P) = open stand (S) = strainer

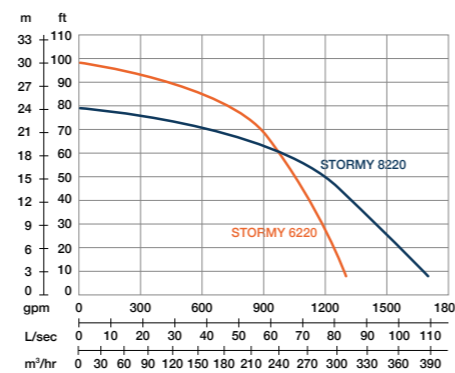

# SUBMERSIBLE SEWAGE PUMPS

- CUTTER PUMPS
- SINGLE CHANNEL PUMPS
- VORTEX SEWAGE PUMPS
- VORTEX & AGITATOR PUMPS

## Robust Design, Real Quality

Designed for excellent performance, low energy consumption, and easy maintenance, PRORIL submersible sewage pumps serve a wide range of sewage transport applications. They are ideal for residential, commercial, industrial sewage transferring, wastewater treatment plant, site drainage, etc.



# SEWAGE PUMPS

## COMMON FEATURES

### 1 Watertight Cable Entry

The cable entry employs an anti-wicking block where each conductor is stripped and encapsulated in epoxy. This feature effectively prevents water from penetrating the motor chamber when the cable end is submerged or the cable sheath is damaged.

### 2 Motor Protector

The motor incorporates a motor protection device which protects against overheating and dry-run. Pumps with a capacitor-run or direct-on line starting motor are equipped with a circle thermal protector. Pumps with a start-delta starting motor are equipped with miniature thermal protectors in each phase.

### 3 Submersible Motor

Air filled motor, housed in a watertight casing, conforms to Class F insulation.

### 4 C3 Ball Bearings and Hardened SS Shaft

High quality of C3 ball bearings and the well-balanced, hardened stainless steel shaft enhance stability during continuous pumping operations.

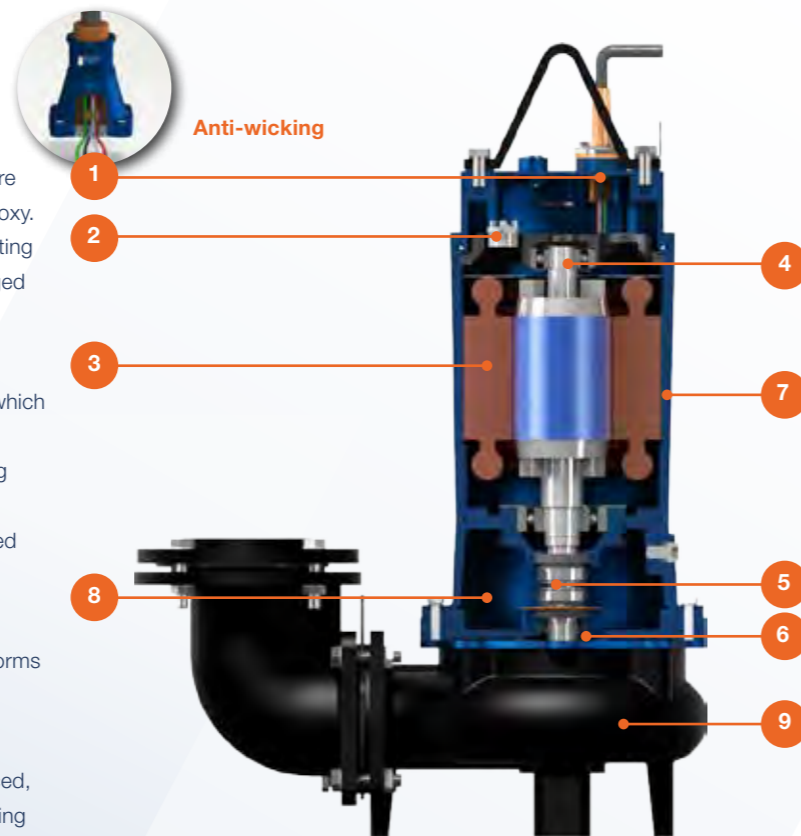

### 5 EagleBurgmann® Double Mechanical Seals

Located in the oil chamber, the device is made of quality materials with highly wear-resistant silicon carbide in lower side that provides extra protection against leakage and dry-run.

### 6 Extra Protection for Mechanical Seals and Shaft

Lip seals and shaft sleeves are utilized for additional protection against wear.

### 7 Rugged Cast Iron Design

The whole cast iron pump features a simple, robust structure that provides durability and impact resistance to rough conditions.

### 8 Food Grade Lubricant

PRORIL adopts eco-friendly lubricant to minimize environmental impacts.



### 9 Impellers and Volutes

Types of impellers and volutes are varied with pump models, cultivated through years of experience in the pump manufacturing industry. They include single channel impellers, vortex impellers, semi-open impellers, grinders, and agitators.

## GOCUT SERIES CUTTER PUMPS

**Discharge Bore :** 50 - 100 mm

**Motor :** 0.4 ~ 3.7 kW, 2-Pole Motor

**Impeller Type :** Semi-Open Channel Cutter impeller

**Features :** Utilizing a cutter mechanism and tungsten carbide alloy to cut fibrous matters and to prevent clogging.

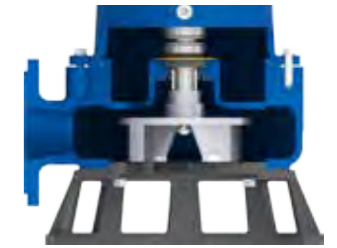

## GOMAX SERIES SINGLE CHANNEL PUMPS

**Discharge Bore :** 80 - 150 mm

**Motor :** 3.7 ~ 22 kW, 4-Pole Motor

**Impeller Type :** Single Channel impeller

**Features :** Passing 76mm diameter solids without clogging.



## GOVOX SERIES VORTEX PUMPS

**Discharge Bore :** 50 - 100 mm

**Motor :** 0.4 ~ 7.5 kW, 2-Pole Motor

**Impeller Type :** Vortex impeller

**Features :** A whirling action enables large solids and fibrous matters to be pumped out without obstruction.



## GOVOX-S SERIES VORTEX & AGITATOR PUMPS

**Discharge Bore :** 80 - 100 mm

**Motor :** 2.2 ~ 3.7 kW, 2-Pole Motor

**Impeller Type :** Vortex impeller

**Features :** Coupled with an agitator, which significantly and efficiently improves solids handling.

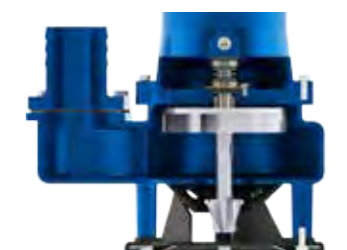

# GOCUT SERIES

## CUTTER PUMPS

- GOCUT Series pumps are designed for handling raw sewages and various wastewater treatments.
- The cutting mechanism shreds fibrous materials into small pieces to prevent from clogging that would happen on a common pump.
- The cutting mechanism consists of a chopper plate and a tungsten carbide alloy tip onto each vane of the semi-open channel impeller.
- Guide rail fittings are available on request.



### GOCUT 208



GOCUT	208
Outlet	2" (50 mm)
Rated Output	0.75 kW
Shaft Speed	2850 rpm
Solid Passage	26 mm
Height	434 mm
Diameter	Ø 301 mm
Weight	21.5 kg

Also available with float switch (A).

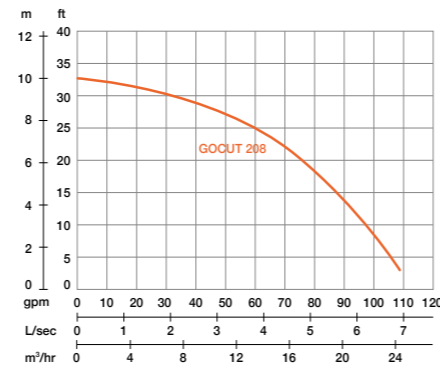

### GOCUT 215 315



GOCUT	215	315
Outlet	2" (50 mm)	3" (80 mm)
Rated Output	1.5 kW	1.5 kW
Shaft Speed	2850 rpm	2850 rpm
Solid Passage	27 mm	27 mm
Height	463 mm	463 mm
Diameter	Ø 301 mm	Ø 301 mm
Weight	26.5 kg	26.5 kg

Also available in 230 Volt (S)

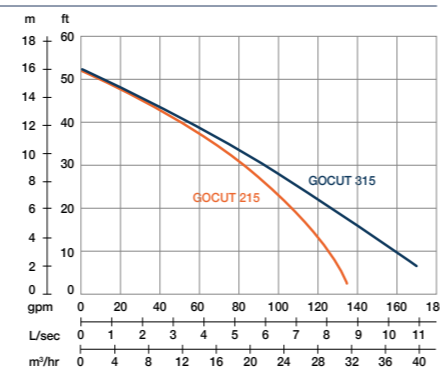

### GOCUT 322 337 437



GOCUT	322	337	437
Outlet	3" (80 mm)	3" (80 mm)	4" (100 mm)
Rated Output	2.2 kW	3.7 kW	3.7 kW
Shaft Speed	2850 rpm	2850 rpm	2850 rpm
Solid Passage	27 mm	37 mm	37 mm
Height	642 mm	642 mm	642 mm
Diameter	Ø 482 mm	Ø 482 mm	Ø 482 mm
Weight	55 kg	59.5 kg	59.5 kg

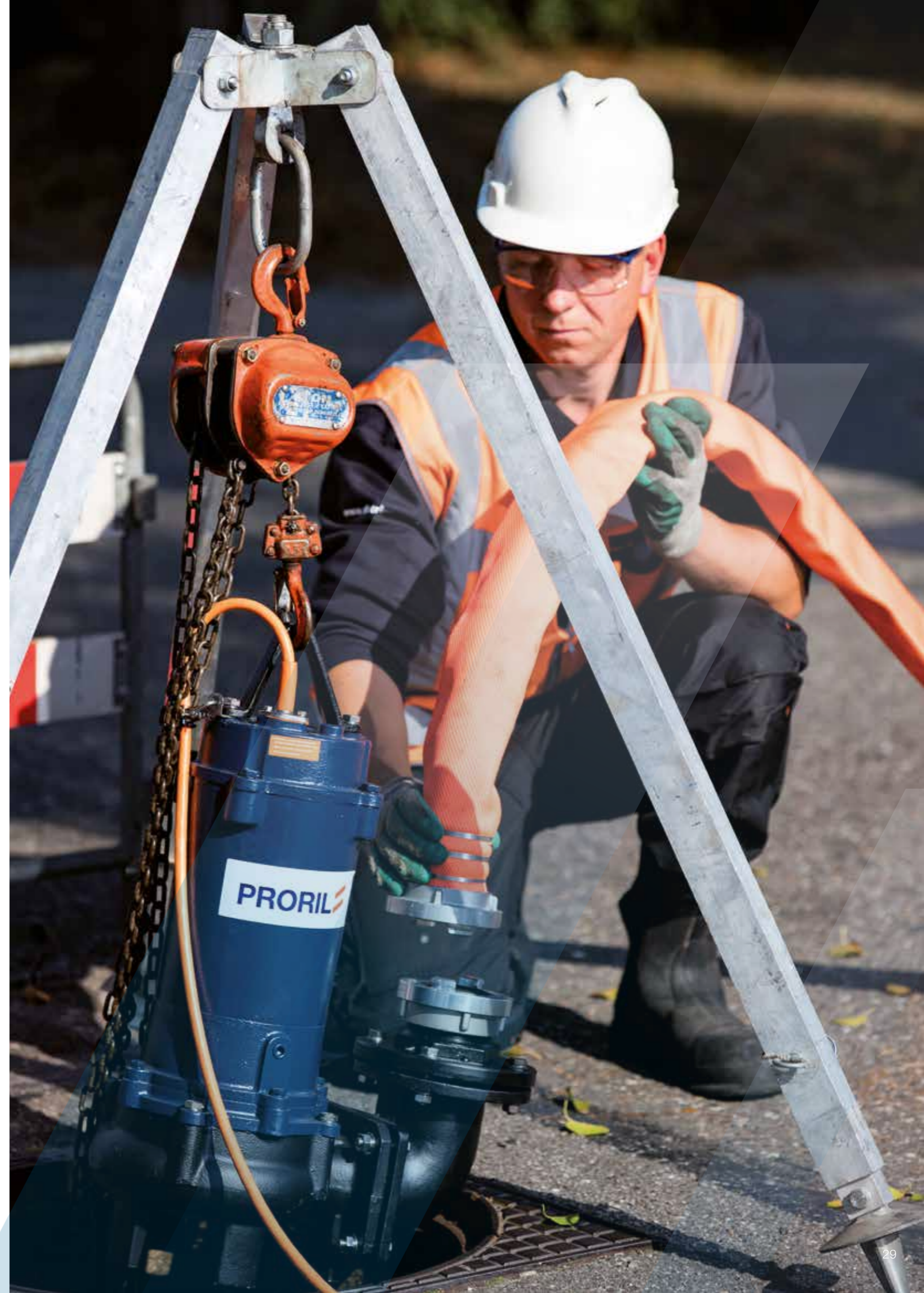
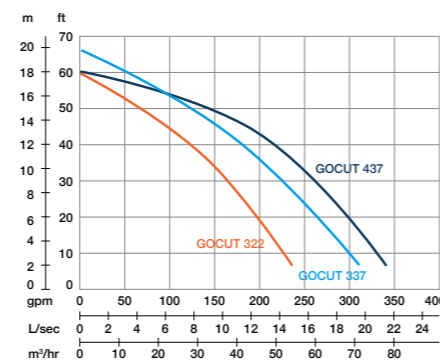

# GOMAX SERIES

## SINGLE CHANNEL PUMPS

- Designed for passing 76mm diameter solids without clogging, GOMAX series employ a single-channel enclosed impeller to efficiently and reliably transfer raw sewage.
- GOMAX series featured high efficiency, non-clogging, long life, and energy saving.
- The design of air release valve in pump casing prevents air lock.
- GOMAX series are suitable for commercial and industrial wastewater applications.
- Guide rail fittings are available on request.



### GOMAX 337 437



GOMAX	337	437
Outlet	3" (80 mm)	4" (100 mm)
Rated Output	3.7 kW	3.7 kW
Shaft Speed	1450 rpm	1450 rpm
Solid Passage	76 mm	76 mm
Height	673 mm	673 mm
Diameter	Ø 580 mm	Ø 589 mm
Weight	94 kg	97 kg

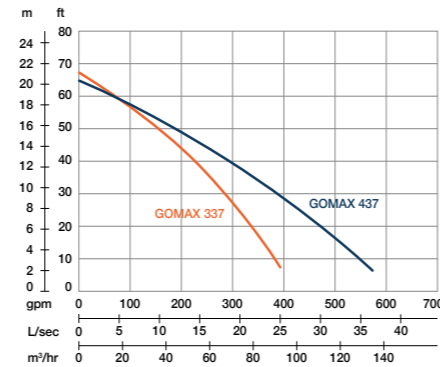

### GOMAX 4110 6110



GOMAX	4110	6110
Outlet	4" (100 mm)	6" (150 mm)
Rated Output	11 kW	11 kW
Shaft Speed	1450 rpm	1450 rpm
Solid Passage	76 mm	76 mm
Height	803 mm	803 mm
Diameter	Ø 753 mm	Ø 813 mm
Weight	167 kg	175 kg

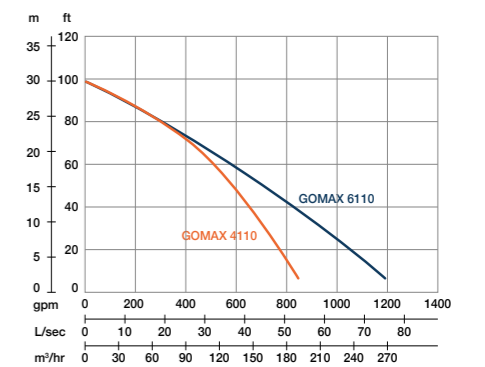

### GOMAX 455 655



GOMAX	455	655
Outlet	4" (100 mm)	6" (150 mm)
Rated Output	5.5 kW	5.5 kW
Shaft Speed	1450 rpm	1450 rpm
Solid Passage	76 mm	76 mm
Height	810 mm	810 mm
Diameter	Ø 693 mm	Ø 752 mm
Weight	132 kg	138 kg

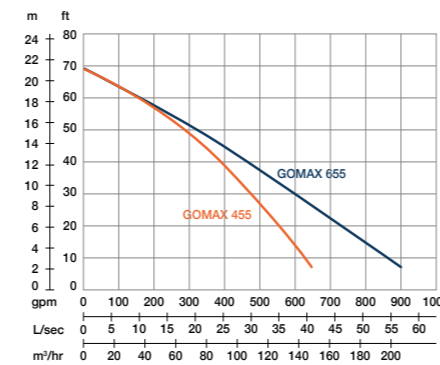

### GOMAX 4150 6150



GOMAX	4150	6150
Outlet	4" (100 mm)	6" (150 mm)
Rated Output	15 kW	15 kW
Shaft Speed	1450 rpm	1450 rpm
Solid Passage	76 mm	76 mm
Height	803 mm	803 mm
Diameter	Ø 753 mm	Ø 813 mm
Weight	178 kg	186 kg

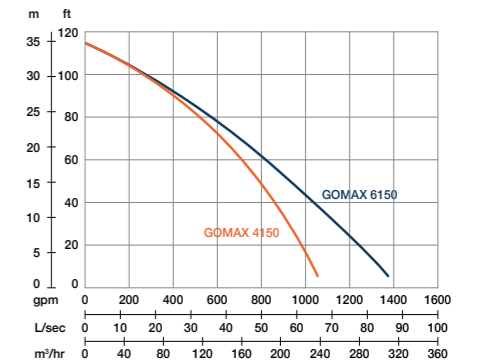

### GOMAX 475 675



GOMAX	475	675
Outlet	4" (100 mm)	6" (150 mm)
Rated Output	7.5 kW	7.5 kW
Shaft Speed	1450 rpm	1450 rpm
Solid Passage	76 mm	76 mm
Height	810 mm	810 mm
Diameter	Ø 693 mm	Ø 752 mm
Weight	142 kg	148 kg

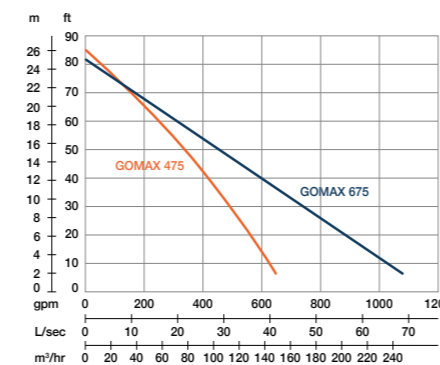

### GOMAX 4220 6220



GOMAX	4220	6220
Outlet	4" (100 mm)	6" (150 mm)
Rated Output	22 kW	22 kW
Shaft Speed	1450 rpm	1450 rpm
Solid Passage	76 mm	76 mm
Height	1007 mm	1007 mm
Diameter	Ø 808 mm	Ø 867 mm
Weight	256 kg	262 kg

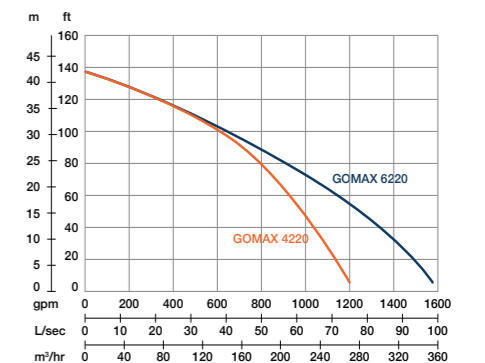



# GOVOX SERIES

## VORTEX SEWAGE PUMPS

- GOVOX series features its vortex impeller coupled with a wide pump casing. The rotation of the impeller produces a whirling, centrifugal action between the impeller and pump casing. The action enables large solids and fibrous matters to be pumped out without obstruction, leading to less impeller wear and longer pump life.
- Guide rail fittings are available on request.

### GOVOX 204



GOVOX	204
Outlet	2" (50 mm)
Rated Output	0.4 kW
Shaft Speed	2850 rpm
Solid Passage	32 mm
Height	395 mm
Diameter	Ø 243 mm
Weight	13.5 kg

Also available with float switch (A).

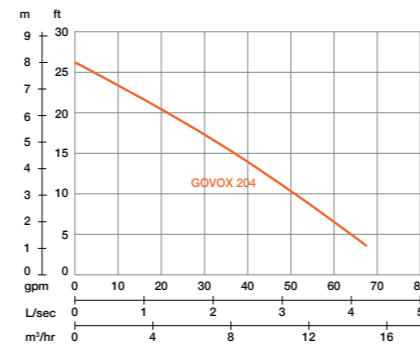

### GOVOX 208 315



GOVOX	208	315
Outlet	2" (50 mm)	3" (80 mm)
Rated Output	0.75 kW	1.5 kW
Shaft Speed	2850 rpm	2850 rpm
Solid Passage	37 mm	50 mm
Height	473 mm	501 mm
Diameter	Ø 243 mm	Ø 302 mm
Weight	19.5 kg	24 kg

GOVOX 315 also available in 230 Volt (S).  
Also available with float switch (A).

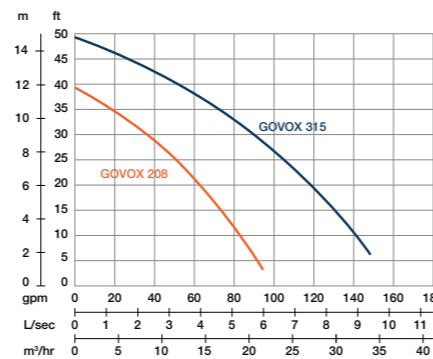

### GOVOX-G 322 337 437



GOVOX-G	322	337	437
Outlet	3" (80 mm)	3" (80 mm)	4" (100 mm)
Rated Output	2.2 kW	3.7 kW	3.7 kW
Shaft Speed	2850 rpm	2850 rpm	2850 rpm
Solid Passage	47 mm	52 mm	52 mm
Height	643 mm	643 mm	643 mm
Diameter	Ø 464 mm	Ø 464 mm	Ø 464 mm
Weight	59.5 kg	64 kg	64 kg

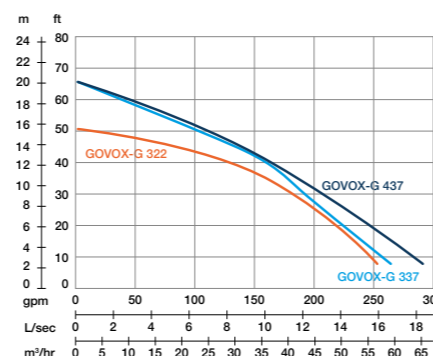

### GOVOX-G 455 475



GOVOX-G	455	475
Outlet	4" (100 mm)	4" (100 mm)
Rated Output	5.5 kW	7.5 kW
Shaft Speed	2850 rpm	2850 rpm
Solid Passage	52 mm	52 mm
Height	695 mm	717 mm
Diameter	Ø 464 mm	Ø 464 mm
Weight	72.5 kg	75 kg

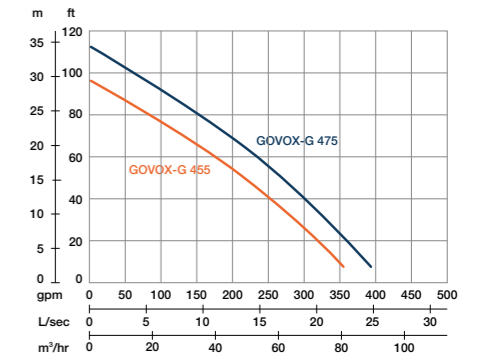

### GOVOX-U 322 337



GOVOX-U	322	337
Outlet	3" (BSP)	3" (BSP)
Rated Output	2.2 kW	3.7 kW
Shaft Speed	2850 rpm	2850 rpm
Solid Passage	55 mm	55 mm
Height	655 mm	712 mm
Diameter	Ø 366 mm	Ø 376 mm
Weight	40 kg	49 kg

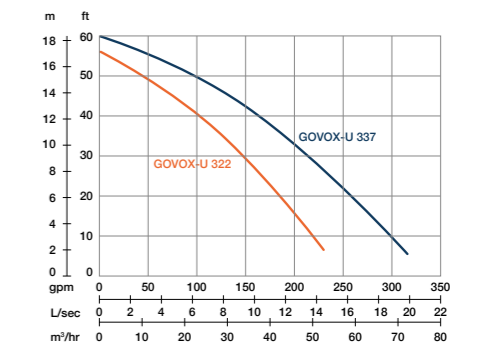

### GOVOX-U 455 475



GOVOX-U	455	475
Outlet	4" (BSP)	4" (BSP)
Rated Output	5.5 kW	7.5 kW
Shaft Speed	2850 rpm	2850 rpm
Solid Passage	55 mm	55 mm
Height	720 mm	754 mm
Diameter	Ø 376 mm	Ø 389 mm
Weight	60 kg	67 kg

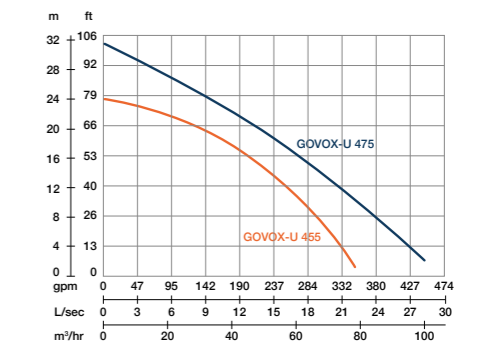

## GOVOX-S SERIES VORTEX & AGITATOR PUMPS

- GOVOX-S series pumps are equipped with an agitator, which forcibly agitates the fluid for easy and efficient transmission of sludge, sand, mud, and debris.
- The agitator prevents air lock that tends to take place on vortex pumps.

### GOVOX-S 322 337



GOVOX-S	322	337
Outlet	3" (BSP)	3" (BSP)
Rated Output	2.2kW	3.7kW
Shaft Speed	2850 rpm	2850 rpm
Solid Passage	13mm	13mm
Height	603mm	660mm
Diameter	Ø373mm	Ø383mm
Weight	43kg	57kg

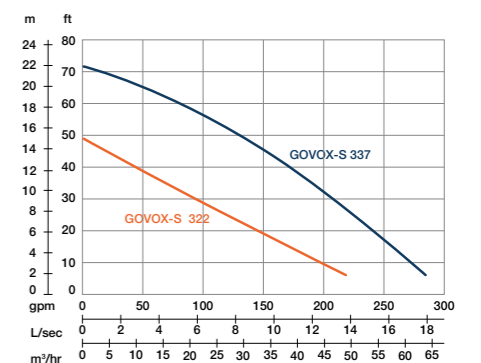

# GUIDE RAIL FITTING SYSTEMS

The guide rail fitting system connects the pump to and from the piping simply just by lowering and elevating the pump. The mechanism allows easy maintenance and inspection without the need to enter the sump.

Pump models used in combination with the guide rail fitting system can be identified by the following index and reference.

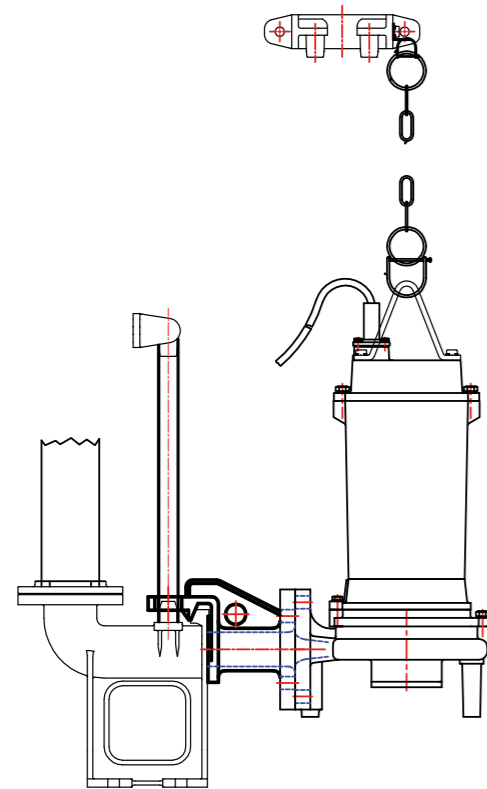

Guide rail system includes:

- Cast iron upper holder.
- 5 meter stainless steel chain.
- Required fixtures.

Guide Rail Type	Applicable Models
GRL-02	GOVOX 204/208
	X-VOX 208/215
GRL-02F	GOCUT 208/215
GRL-03F	GOCUT 315
	GOVOX 315
GRF-03	GOCUT 322/337
	GOVOX-G 322/337
GRF-04	GOCUT 437
	GOVOX-G 437/455/475
GRN-03	GOMAX 322/337/437
	GOMAX 455/655/475/675
GRN-04	GOMAX 475/675
	GOMAX 4110/6110
	GOMAX 4150/6150
	GOMAX 4220/6220
	GOMAX 4220/6220





# HANDY & RESIDUE PUMPS

Simple Structure, Real Quality

Designed for light weight, excellent performance, low energy consumption, and easy maintenance, PRORIL's submersible handy and residue pumps serve a wide range of pumping applications on utility, construction, industrial, and municipal job sites.



# SMART SERIES

## HANDY & RESIDUE PUMPS

Compact, lightweight and easy to use, the SMART series pumps deliver high performance for their size. These small but effective dewatering pumps are easily maintained and perfect for a variety of applications, such as small construction sites, rental industries, and municipal jobs.

### FEATURES

#### 1 Watertight Cable Entry

The cable entry employs an anti-wicking block where each conductor is stripped and encapsulated in epoxy. This feature effectively prevents water from penetrating the motor chamber when the cable end is submerged or the cable sheath is damaged.

#### 2 Top Discharge and Double Housing Design

Designed to construct a water jacket that provides maximum motor cooling effect for continuous operation at low water level, this feature forms the cylindrical and slim shape of the pump and enables the pump to be installed in confined spaces.

#### 3 Motor Protector

The motor incorporates a circle thermal protector which protects against overheating and dry-run.

#### 4 Submersible Motor

Air filled motor, housed in a watertight casing, conforms to Class F insulation.

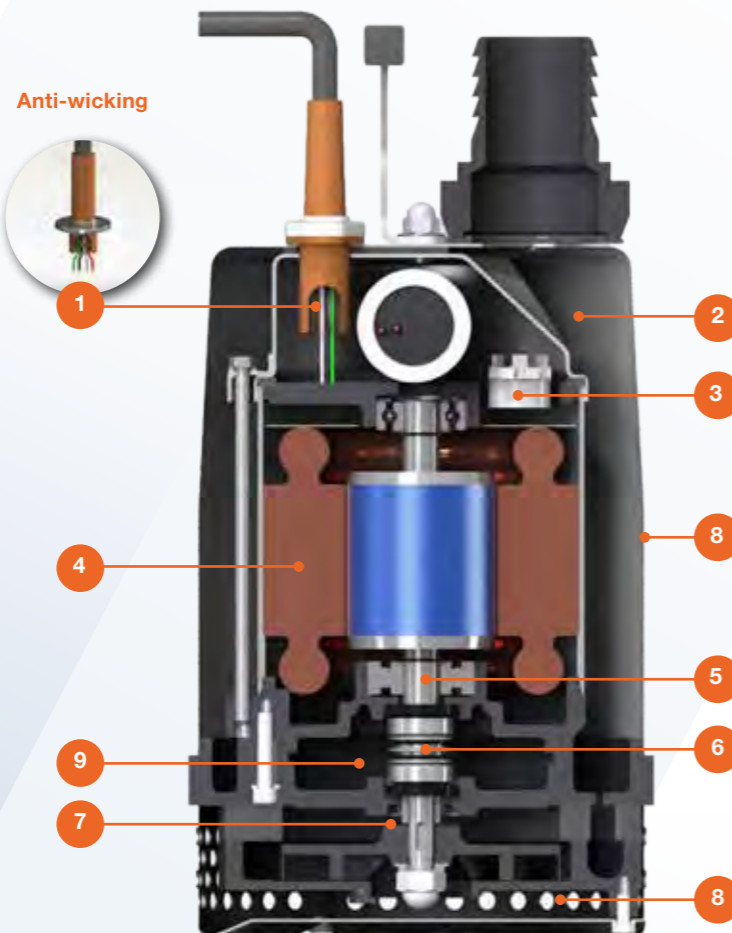

Anti-wicking

1

2

3

4

5

6

9

7

8

#### 5 C3 Ball Bearings and Hardened SS Shaft

High quality of C3 ball bearings and the well-balanced, hardened stainless steel shaft enhance stability during continuous pumping operations.

#### 6 EagleBurgmann® Double Mechanical Seals

Located in the oil chamber, the device is made of quality materials with highly wear-resistant silicon carbide in lower side that provides extra protection against leakage and dry-run.

#### 7 Extra Protection for Mechanical Seals and Shaft

Lip seals and shaft sleeves are utilized for additional protection against wear.

#### 8 Durable Outer Jacket and Strainer

The outer housing and strainer made of 304 stainless steel provide impact resistant to harsh handling and conditions.

#### 9 Food Grade Lubricant

PRORIL adopts eco-friendly lubricant to minimize environmental impacts.



### SMART

### 400 750



SMART	400	750
Outlet	2" (BSP)	2" (BSP)
Rated Output	0.4 kW	0.75 kW
Shaft Speed	2850 rpm	2850 rpm
Solid Passage	5.5 mm	7 mm
Height	333 mm	361 mm
Diameter	Ø 184 mm	Ø 184 mm
Weight	12.5 kg	14 kg

Also available with float switch (A).

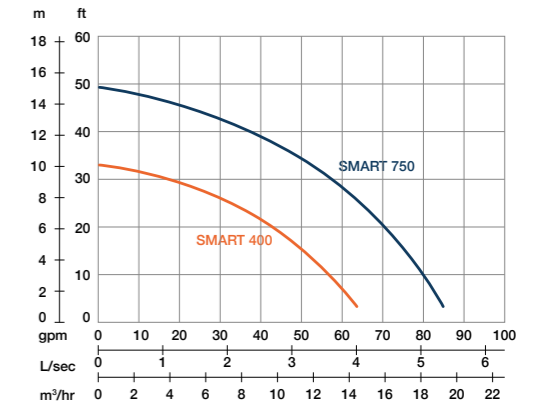

### SMART

### 1500



SMART	1500
Outlet	2" (BSP)
Rated Output	1.5 kW
Shaft Speed	2850 rpm
Solid Passage	9 mm
Height	433 mm
Diameter	Ø 225 mm
Weight	23.5 kg

Also available in 230 Volt (S).

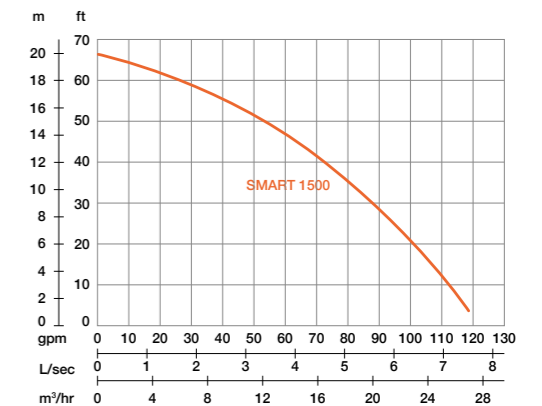

### SMART BASE

### 400



SMART BASE	400
Outlet	1" (BSP) 2" (BSP)
Rated Output	0.4 kW
Shaft Speed	2850 rpm
Solid Passage	2 mm
Height	336 mm
Diameter	Ø 206 mm
Weight	14 kg

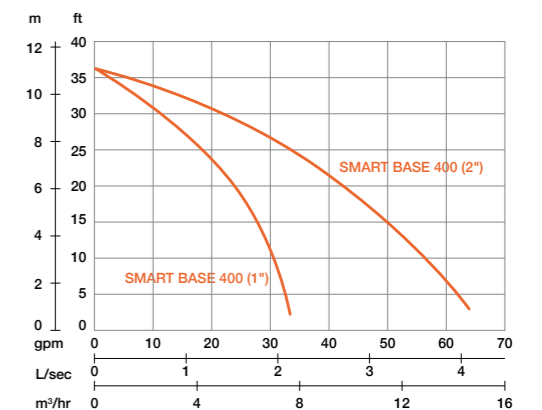

# SMART LITE

Small, lightweight and cost-effective, the SMART LITE pumps perform an excellent job for their size. These small but effective dewatering pumps are easily maintained and perfect for a variety of applications, such as small construction sites, rental industries, and municipal jobs.

## FEATURES

- **Watertight cable entry** prevents water incursion from the capillary wicking.
- **Multi-Direction Discharge** can be changed between vertical and horizontal ways.
- **Slim line design** allows access into limited space.
- **Double housing** forms a water jacket to greatly cool the motor.
- **A thermal protector** is used on the motor to protect against overheating and dry-run.
- **Air filled motor**, housed in a watertight casing, conforms to Class F insulation.
- **C3 Ball Bearings and Hardened SS Shaft** enhance stability during operation.
- **Mechanical Sic Seal** in lower side provides extra protection against leakage and dry-run.
- **A Lip Seal** works as an extra protection for mechanical seal from wear.
- **PU Impeller** is adopted for easy maintenance.
- **Food Grade Lubricant** helps minimizing environmental impacts.

## SMART LITE BASE 400



SMART LITE BASE	400
Outlet	1" (BSP) 2" (BSP)
Rated Output	0.4 kW
Shaft Speed	2850 rpm
Solid Passage	2 mm
Height	304 mm
Diameter	Ø 215 mm
Weight	10,5 kg

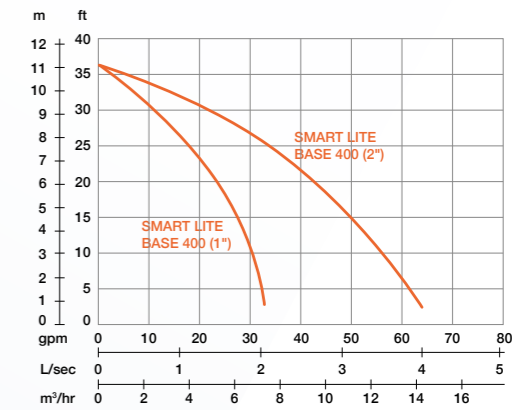

## SMART LITE 400



SMART LITE	400
Outlet	2" (BSP)
Rated Output	0.4 kW
Shaft Speed	2850 rpm
Solid Passage	5.5 mm
Height	303 mm
Diameter	Ø 205 mm
Weight	8 kg

Also available with float switch (A).

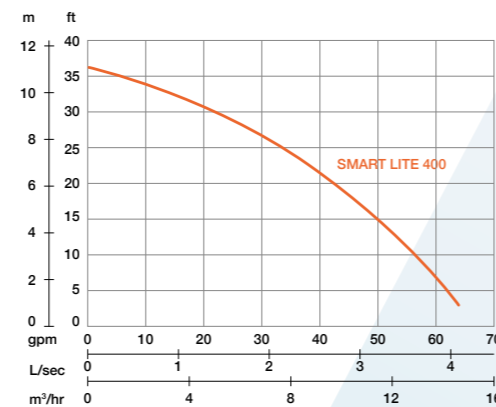

## SMART LITE 750



SMART LITE	750
Outlet	2" (BSP)
Rated Output	0.75 kW
Shaft Speed	2850 rpm
Solid Passage	7 mm
Height	343 mm
Diameter	Ø 205 mm
Weight	12.5 kg

Also available with float switch (A).

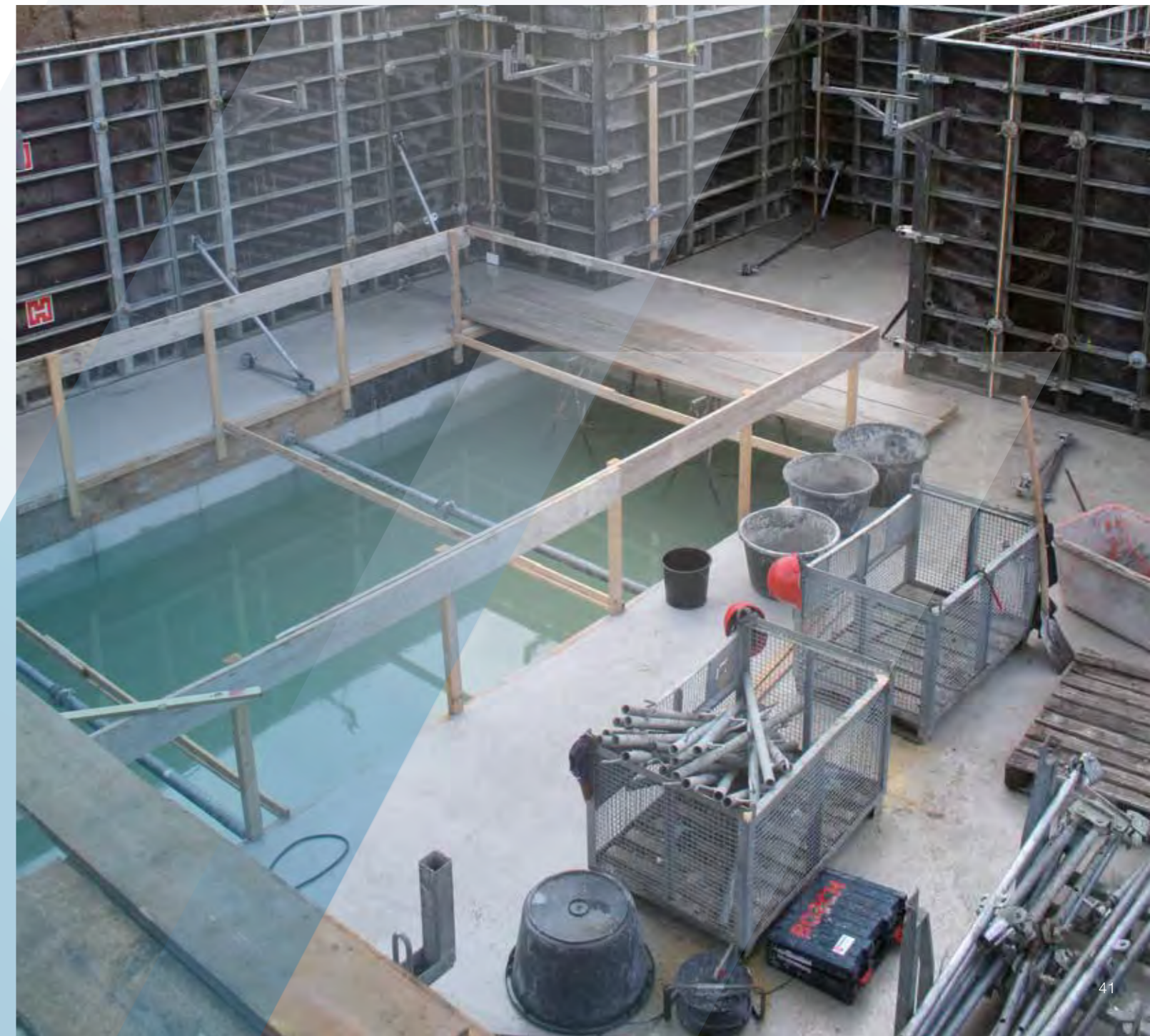
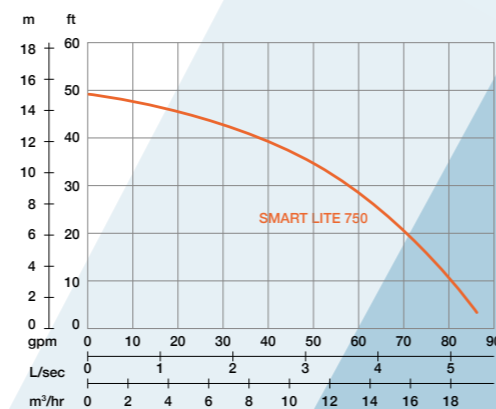

# SAVVY SERIES

## HANDY & RESIDUE PUMPS

The SAVVY series pumps are suitable for a variety of domestic applications, including draining basements and garages, emptying swimming pool and fountains, gardening, and hobby applications in general.

### FEATURES

#### 1 Watertight Cable Entry

Watertight cable entry prevents water incursion from the capillary wicking.

#### 2 Durable Outer Housing

The outer housing made of 304 stainless steel provides impact resistant to harsh handling and conditions.

#### 3 Motor Protector

The motor incorporates a miniature thermal protector which protects against overheating and dry-run.

#### 4 Submersible Motor

Air filled motor, housed in a watertight casing, conforms to Class F insulation.

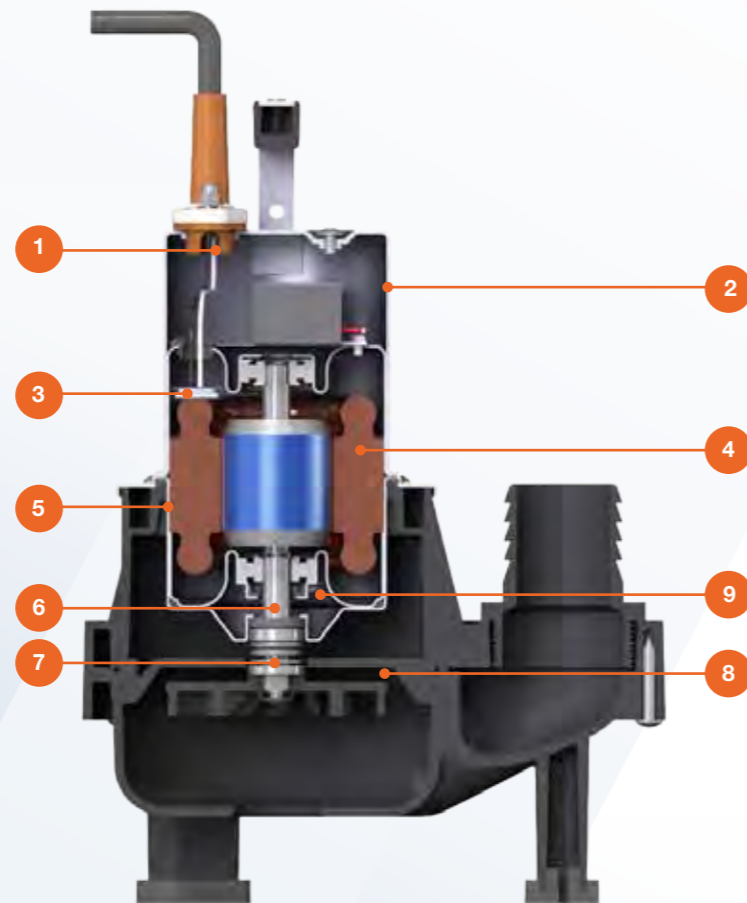

#### 5 Stainless Steel 304 Motor Housing

The material provides superior corrosion resistance.

#### 6 C3 Ball Bearings and Hardened SS Shaft

High quality of C3 ball bearings and the well-balanced, hardened stainless steel shaft enhance stability during continuous pumping operations.

#### 7 Mechanical Seal

The premium mechanical seal provides extra protection against leakage and longer life span.

#### 8 Impact-resistant Nylon pump casing and suction grid

Lightweight design and corrosion-resistance.

#### 9 Food Grade Lubricant

PRORIL adopts eco-friendly lubricant to minimize environmental impacts.



# SAVVY 150

## FEATURES

- Compact, lightweight, and easy-to-use design
- SAVVY 150 : Aluminum alloy outer case with lightweight top cover, impeller, and suction grids.
- Air filled motor with Class F insulation.
- Thermal protection on motor.
- Built-in high torque capacitor.
- Triple seals design.
- Removable filter screen for easy maintenance.

### SAVVY | 150



SAVVY	150
Outlet	1" (25 mm)
Rated Output	0.15 kW
Shaft Speed	2850 rpm
Solid Passage	6 mm
Height	273 mm
Diameter	Ø 158 mm
Weight	3.2 kg

Also available with float switch (A).

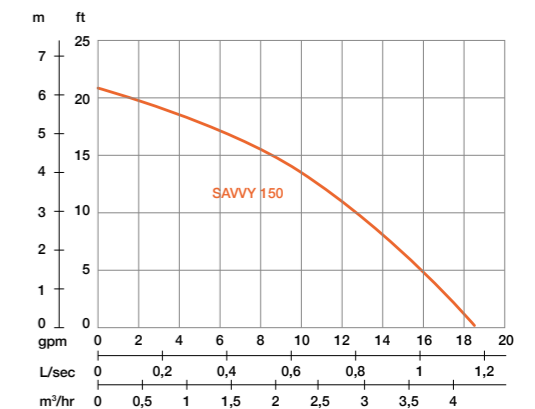

**SAVVY**

**300 600**



SAVVY	300	600
Outlet	2" (50 mm)	2" (50 mm)
Rated Output	0.25 kW	0.55 kW
Shaft Speed	2850 rpm	2850 rpm
Solid Passage	6 mm	6 mm
Height	306 mm	341 mm
Diameter	Ø 244 mm	Ø 244 mm
Weight	4 kg	6 kg

Also available with float switch (A).

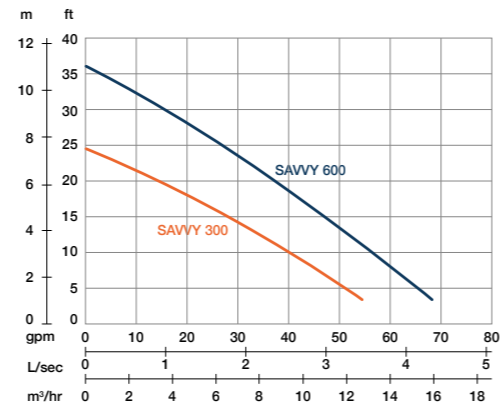

**SAVVY JUMBO**

**300 600**



SAVVY JUMBO	300	600
Outlet	2" (50 mm)	2" (50 mm)
Rated Output	0.25 kW	0.55 kW
Shaft Speed	2850 rpm	2850 rpm
Solid Passage	35 mm	35 mm
Height	337 mm	372 mm
Diameter	Ø 245 mm	Ø 245 mm
Weight	4.2 kg	6 kg

Also available with float switch (A).

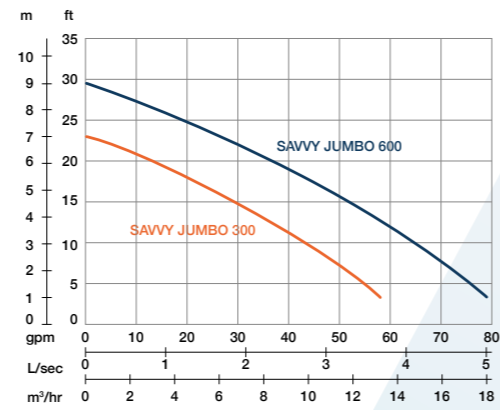

**SAVVY BASE**

**300 600**



SAVVY BASE	300	600
Outlet	1" (25 mm)	2" (50 mm)
Rated Output	0.25 kW	0.55 kW
Shaft Speed	2850 rpm	2850 rpm
Solid Passage	2 mm	5 mm
Height	304 mm	357 mm
Diameter	Ø 244 mm	Ø 244 mm
Weight	4 kg	6 kg

Also available with float switch (A).

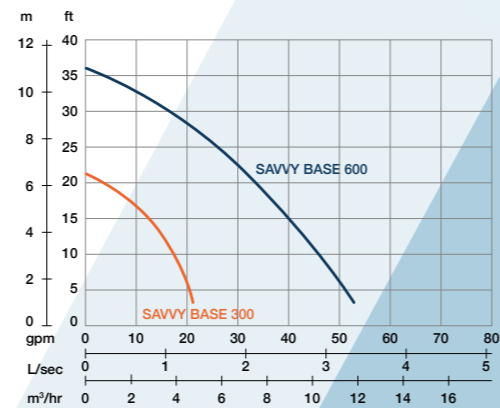



# STAINLESS STEEL PUMPS

PRORIL stainless steel pumps consist of four dewatering pumps and two sewage pumps. All components in contact with the liquid are made of 304 stainless steel.





# STAINLESS STEEL PUMPS

## DEWATERING & SEWAGE VORTEX

PRORIL stainless steel pumps consist of four dewatering pumps and two sewage pumps. All components in contact with the liquid are made of 304 stainless steel.

These pumps are designed for handling clean water or screened wastewater, also applicable to the aquaculture industry with the use of the food-grade lubricant.

### FEATURES

#### 1 Watertight Cable Entry

The cable entry employs an anti-wicking block where each conductor is stripped and encapsulated in epoxy. This feature effectively prevents water from penetrating the motor chamber when the cable end is submerged or the cable sheath is damaged.

#### 2 Top Discharge and Double Housing Design

Designed to construct a water jacket that provides maximum motor cooling effect for continuous operation at low water level, this feature forms the cylindrical and slim shape of the pump and enables the pump to be installed in confined spaces.

#### 3 Motor Protector

The motor incorporates a circle thermal protector which protects against overheating and dry-run.

#### 4 Submersible Motor

Air filled motor, housed in a watertight casing, conforms to Class F insulation.

#### 5 C3 Ball Bearings and Hardened SS Shaft

High quality of C3 ball bearings and the well-balanced, hardened stainless steel shaft enhance stability during continuous pumping operations.

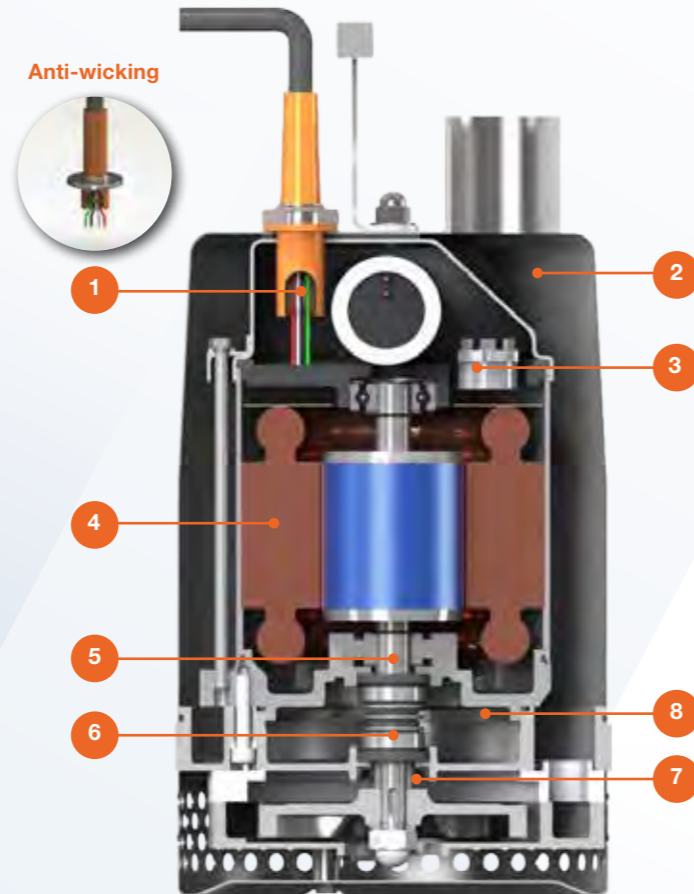

#### 6 EagleBurgmann® Double Mechanical Seals

Located in the oil chamber, the device is made of quality materials with highly wear-resistant silicon carbide in lower side that provides extra protection against leakage and dry-run.

#### 7 Extra Protection for Mechanical Seals and Shaft

Lip seals and shaft sleeves are utilized for additional protection against wear.

#### 8 Food Grade Lubricant

PRORIL adopts eco-friendly lubricant to minimize environmental impacts.



### X-SMART | 400 750



X-SMART	400	750
Outlet	2" (BSP)	2" (BSP)
Rated Output	0.4 kW	0.75 kW
Shaft Speed	2850 rpm	2850 rpm
Solid Passage	5.5 mm	7 mm
Height	333 mm	361 mm
Diameter	Ø 180 mm	Ø 180 mm
Weight	13 kg	14 kg

Also available with float switch (A).

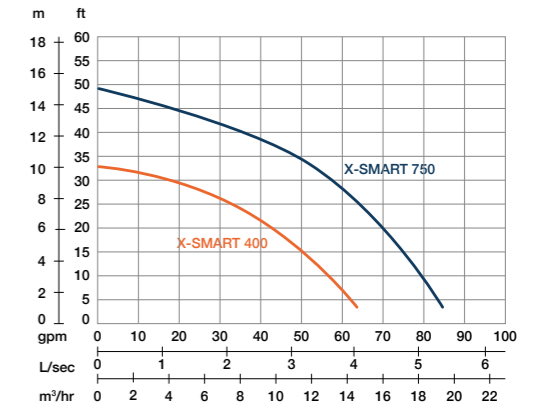

### X-SMART | 215 315



X-SMART	215	315
Outlet	2" (BSP)	3" (BSP)
Rated Output	1.5 kW	1.5 kW
Shaft Speed	2850 rpm	2850 rpm
Solid Passage	7 mm	7 mm
Height	449 mm	449 mm
Diameter	Ø 186 mm	Ø 186 mm
Weight	19 kg	19 kg

Also available in 230 Volt (S).

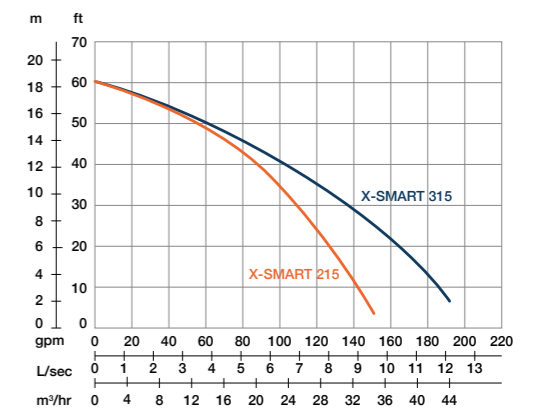

### X-VOX | 208 215



X-VOX	208	215
Outlet	2" (50 mm)	2" (50 mm)
Rated Output	0.75 kW	1.5 kW
Shaft Speed	2850 rpm	2850 rpm
Solid Passage	40 mm	37 mm
Height	415 mm	445 mm
Diameter	Ø 233 mm	Ø 233 mm
Weight	12 kg	15 kg

X-Vox 208 also available with float switch (A).  
X-Vox 215 also available in 230 Volt (S).

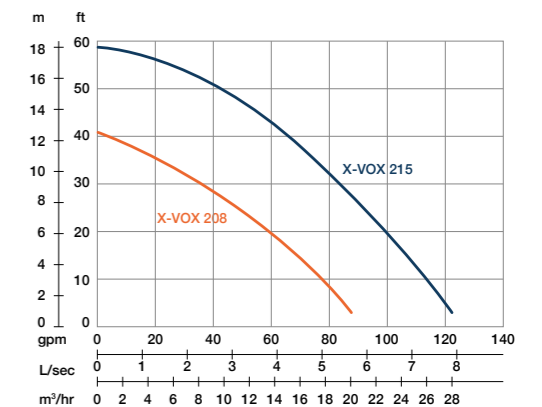

# ACCESSORIES

## PROTECTOR PLUGS

### THERMAL AND CURRENT OVERLOAD MOTOR PROTECTOR PLUGS

Standard with phase inverter and sequence indicator.



Article number	MPP code 28	Setting range	Volt	Type plug - 32 A
AFMPP03-32	28	2,5 A - 4,0 A	400	CEE 32 A - 5 pole
AFMPP05-32	29	4,0 A - 6,3 A	400	CEE 32 A - 5 pole
AFMPP07-32	30	6,3 A - 10,0 A	400	CEE 32 A - 5 pole
AFMPP09-32	31	10,0 A - 16,0 A	400	CEE 32 A - 5 pole
AFMPP11-32	32	16,0 A - 20,0 A	400	CEE 32 A - 5 pole
AFMPP13-32	33	20,0 A - 25,0 A	400	CEE 32 A - 5 pole
AFMPP15-32	34	25,0 A - 32,0 A	400	CEE 32 A - 5 pole

### FLOAT SWITCH SOLUTION FOR 400 VOLT PUMPS TOGETHER WITH THERMAL AND CURRENT OVERLOAD PROTECTION

To be used in combination with the floatswitches. **Auto - 0 - Manual.**



Article number	Max. kW	Setting range	Volt	Type plug - 32 A
AFMPPCWF01-32	7,5	1,6 A - 2,4 A	400	CEE 32 A - 5 pole
AFMPPCWF02-32	7,5	2,4 A - 4,0 A	400	CEE 32 A - 5 pole
AFMPPCWF03-32	7,5	4,0 A - 6,0 A	400	CEE 32 A - 5 pole
AFMPPCWF04-32	7,5	6,0 A - 10,0 A	400	CEE 32 A - 5 pole
AFMPPCWF05-32	7,5	9,0 A - 12,0 A	400	CEE 32 A - 5 pole
AFMPPCWF06-32	7,5	12,0 A - 16,0 A	400	CEE 32 A - 5 pole
AFMPPCWF07-32	15	16,0 A - 20,0 A	400	CEE 32 A - 5 pole
AFMPPCWF08-32	15	20,0 A - 25,0 A	400	CEE 32 A - 5 pole
AFMPPCWF09-32	15	25,0 A - 32,0 A	400	CEE 32 A - 5 pole

## FLOAT SWITCH

### FLOAT SWITCH TO BE USED IN COMBINATION WITH MPPCWF PLUGS

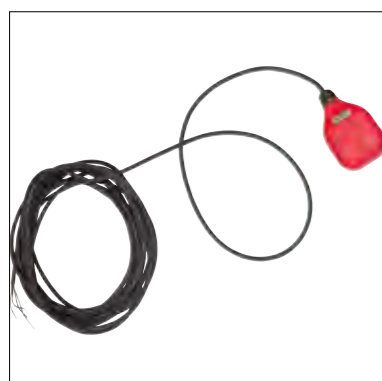

Article number	No. wire	Length mtr.	Volt
5600070	2	10	230
5600090	2	20	230

# GUIDE RAIL FITTING SYSTEMS

The guide rail fitting system connects the pump to and from the piping simply just by lowering and elevating the pump. The mechanism allows easy maintenance and inspection without the need to enter the sump.

Pump models used in combination with the guide rail fitting system can be identified by the following index and reference.

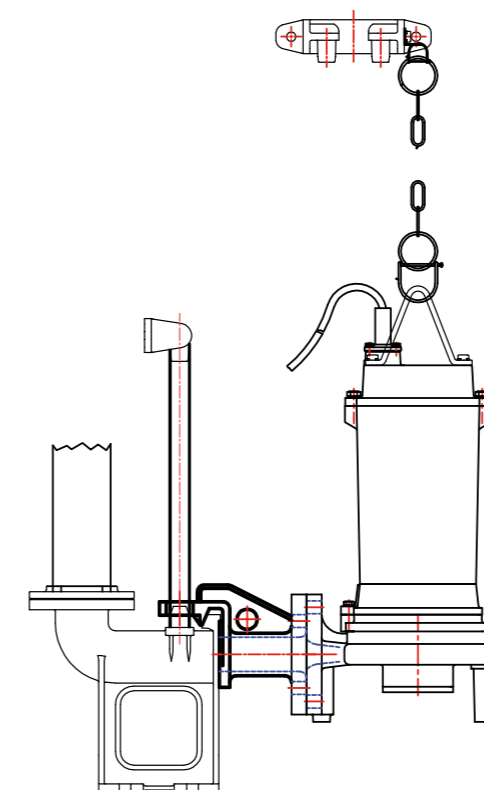

Guide rail system includes:

- Cast iron upper holder.
- 5 meter stainless steel chain.
- Required fixtures.

Guide Rail Type	Applicable Models
GRL-02	GOVOX 204/208
	X-VOX 208/215
GRL-02F	GOCUT 208/215
GRL-03F	GOCUT 315
	GOVOX 315
GRF-03	GOCUT 322/337
	GOVOX-G 322/337
GRF-04	GOCUT 437
	GOVOX-G 437/455/475
GRN-03	GOMAX 322/337/437
	GOMAX 455/655/475/675
GRN-04	GOMAX 475/675
	GOMAX 4110/6110
	GOMAX 4150/6150
	GOMAX 4220/6220

# TECHNICAL INFORMATION

## INSTALLATION

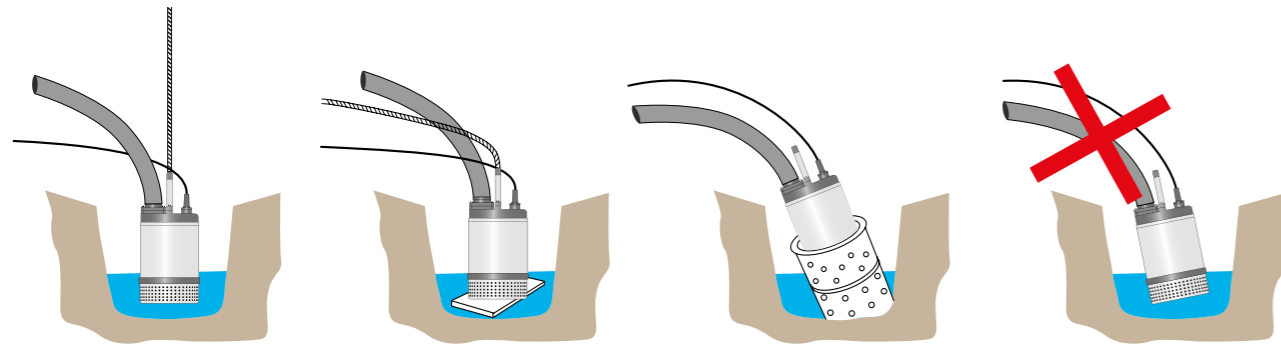

### CORRECT INSTALLATION OF THE PUMPS

Although installing PRORIL submersible pumps is fairly straightforward, there are a few basic things that need to be taken into consideration to ensure optimal performance and to prevent excessive wear and/or damages.

Firstly, it is paramount that the pump is prevented from digging itself into the soil, which is particularly common on sites with sandy- or clay type soils. This can be achieved by suspending the pump above the bottom of the casing using a rope/chain in case of deepwell applications, or by placing the pump on a base of some sort (e.g. wooden plank or coarse gravel) in case of open sump pumping.

Secondly you should prevent tight bends and kinks in the discharge hose at all times. When bent strongly, the maximum flow capacity of the hose is reduced and it will create additional friction losses and will reduce the overall flow performance of the pump.

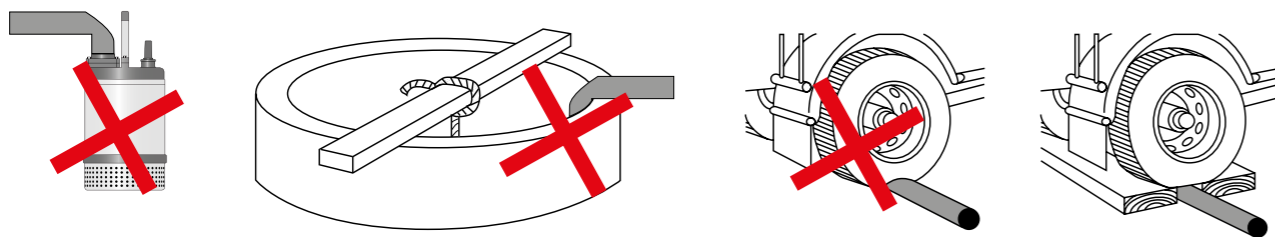

# TECHNICAL INFORMATION

## CHART FOR CALCULATING FRICTION LOSSES IN HOSES

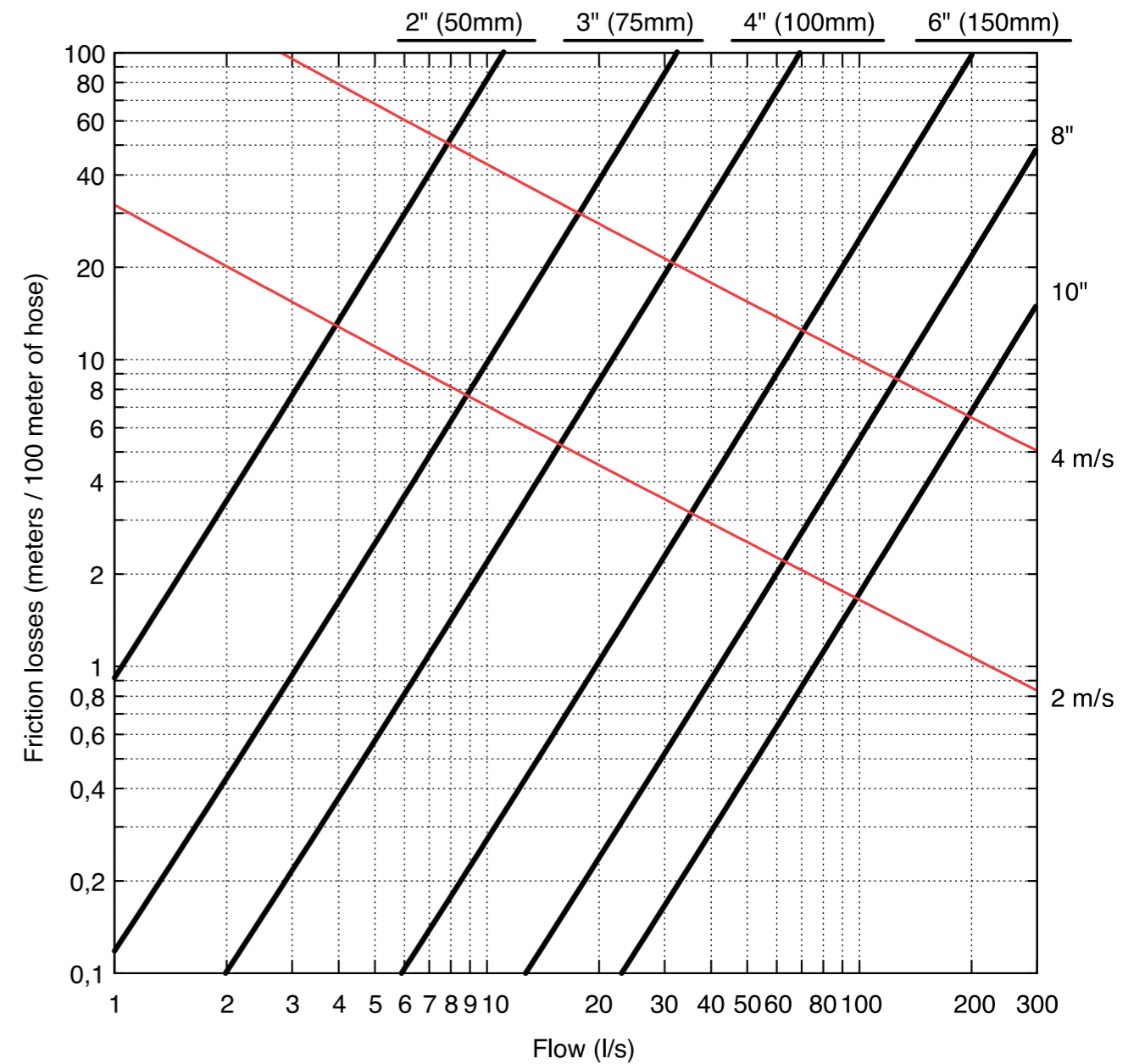

# TECHNICAL INFORMATION

## CONVERSION CHARTS

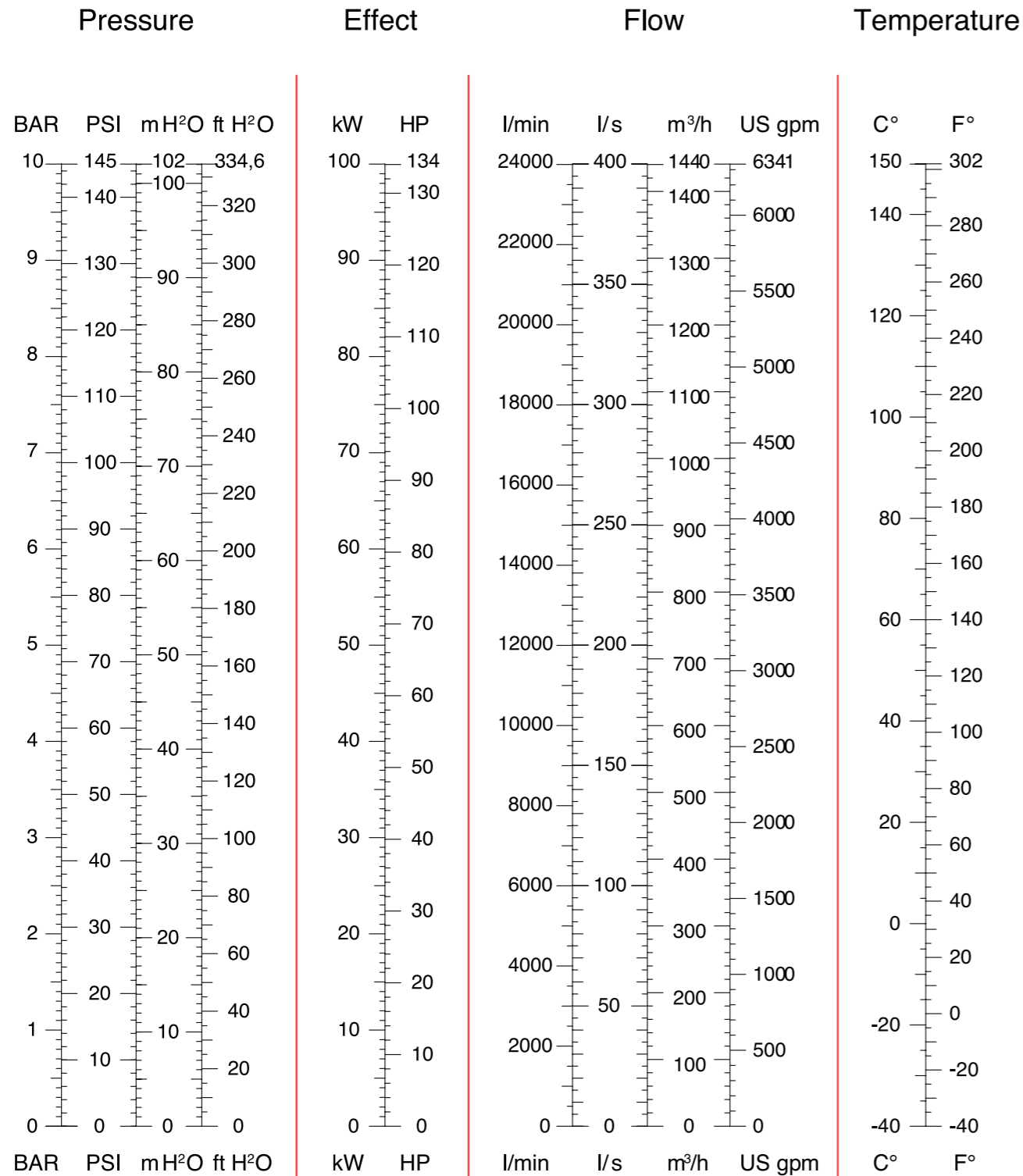

# TECHNICAL INFORMATION

## TYPE OF IMPELLER

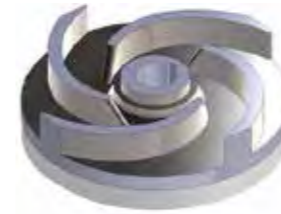

### SEMI-OPEN IMPELLER

An impeller that has no bottom shroud. Liquid which passes through the impeller is deflected, forming a plain perpendicular to the spindle. Most of submersible contractors' pumps employ this type of impeller.



### VORTEX IMPELLER

An indented impeller produces a whirling, centrifugal action which allows long and fibrous material, solid materials, etc. to be pumped without contacting the impeller.



### PERIPHERAL IMPELLER

The impeller has a number of slots on its periphery, and the rotation gives energy to the liquid. Low volume and high head, and widely used in shallow pumps.



### CLOSED IMPELLER

The impeller vanes are enclosed in a unified construction. Suited for high-head pumping.



### AGITATOR

The rigid agitator delivers kinetic energy (energy of motion) to stir solids surrounding the pump intake, re-suspending them into a fluid state for easy pumping.



### SEMI-OPEN CHANNEL IMPELLER

This type of impeller is designed with single or twin circular shaped vanes. This construction is effective in the prevention of blockage by solid matters.

## **PRORIL Pumps Europe BV**

Edisonstraat 12a  
7006 RD Doetinchem  
The Netherlands

P.O. Box 384  
7000 AJ Doetinchem  
The Netherlands

+31 (0) 314 625 125

info@prorilpumpseurope.com  
www.prorilpumpseurope.com

## **PRORIL PUMPS CORPORATION**

60 Lana 251, Zhongzheng Rd.  
Dashe Dist. Kaohsiung 815  
Taiwan (R.O.C.)

**PRORIL** 

Forhandler



**Skibåsen 38 - 4636 Kristiansand**  
**Tlf.: 38 12 91 00 - post@sletteboe.no**