

SOLID BUSHING & ROLLER

**Silver
SBR**

**GREATEST
QUALITY
IN
ROLLER
CHAIN**



SUGIYAMA

TO SLETTEBØE AS
WWW.SLETTEBOE.NO

-En enklere arbeidsdag!

SUGIYAMA CHAIN CO., LTD.

Since being founded in 1946 as a bicycle chain manufacturer, Sugiyama Chain has concentrated its efforts on the manufacturing of high quality roller chain. With decades of experience and continuous research in the roller chain field, we offer a complete line of roller chain. Our chain is recognized throughout the world for its quality and innovation. Sugiyama Chain obtained ISO 9001 certification in December 2000 further enhancing its quality assurance. Our mission is to provide the highest quality roller chain with strength, durability, and reliability to our customer's satisfaction. We will continue to perfect our chain under our strict quality control system. Most of the items in this catalog are available from SY's distributors all over the world, or are in stock at Service Centers.

Certificate Number : JQA-QM5873

Organization :
SUGIYAMA CHAIN CO.,LTD.



Scope of Registration :

DESIGN, DEVELOPMENT AND MANUFACTURE OF PRESSION POWER
TRANSMISSION ROLLER CHAIN, LEAF CHAIN AND CONVEYOR CHAIN.



SY's advanced research and development

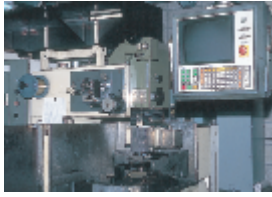

DIES AND OTHERS

Improved, sophisticated dies are studied and developed in our factory shop.



MODERNIZED HEAT TREATMENT EQUIPMENT

Our heat treatment equipments have been updated for severe control on heated parts.

Also, extreme attention is given to the quality control of the heat treated parts.



ADVANCED FULLY AUTOMATIC ASSEMBLY MACHINE

Our newly designed advanced automatic assembly machines provide greater uniformity and closer tolerance of the products.



QC DEPARTMENT

Your ordered chains are carefully and closely inspected at each production process by our QC-oriented specialists.



AUTOMATIC STORAGE AND HANDLING SYSTEM

Handling of many different parts and semi-finished products are effectively controlled for production.



COLD FORGING MACHINES

Main frame for SBR Solid Bushing and SBR Solid Roller are made with these machines.



FATIGUE TEST MACHINE

Very important for the quality evaluation for further improvement of the chain life.

SY's new products guide

Solid Bushing and Roller
see page 4 ~ 5

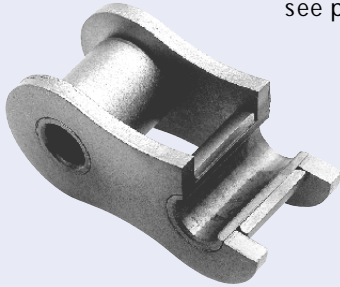

New Connecting Link
see page 4

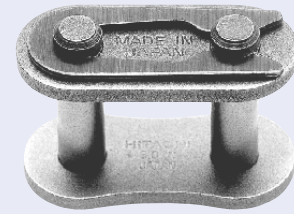

patent pending

Silver - SBR
see page 4

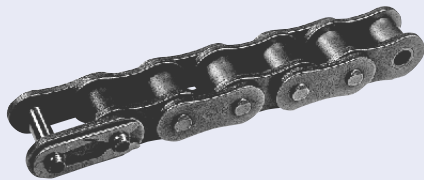

patent pending

Double Capacity Chain
see page 32

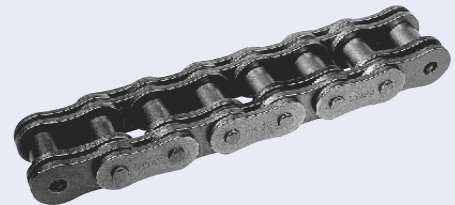

SSS series Stainless Steel Chain
see page 36

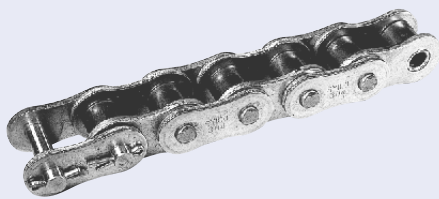

patent pending

Aqua - Proof Roller Chain
see page 40



Self - Lube Chain
see page 48



Maintenance Free Roller Chain
see page 56



patent pending

Silver SBR®

NEW ROLLER CHAIN has up to 25%
Higher Working Loads
With big 5 point for Roller Chain

Solid Bushing and Roller
High Allowable Load
New Connecting Link
Long Life
Excellent appearance

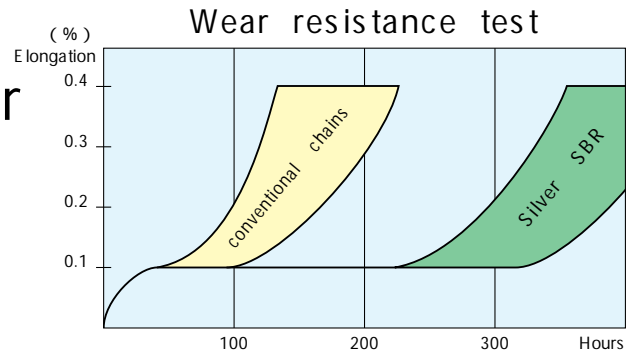

New Connecting Link
Connecting Link have the same strength as chain.

Excellent appearance by
Silver Color
Plate & Roller

High Allowable Load
Close to Super Chain By
Special Pin
(25% higher for #60 to #160)

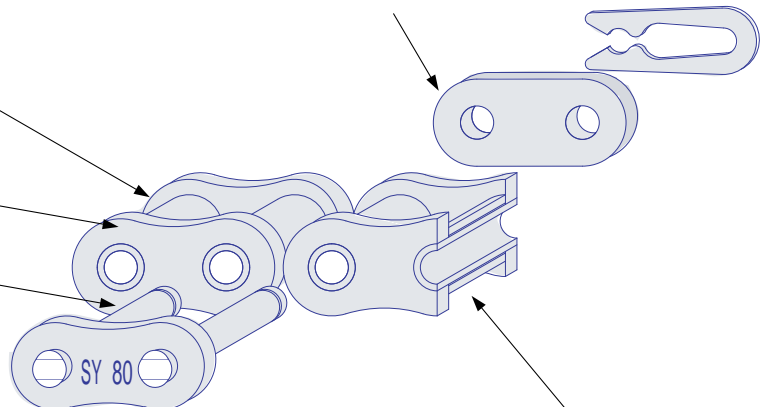

Solid Bushing & Roller

Long Life by Bushing More than 2 time (by our test)
SY Solid Bushing assures perfect straight ID.
surface after assembly.

THE ULTIMATE ROLLER CHAIN LONG LIFE SERIES

SBR[®]
Silver SBR
ROLLER CHAIN

BS STANDARD ROLLER CHAINS
ANSI STANDARD ROLLER CHAINS
STRAIGHT SIDEBAR CHAINS
HEAVY-SERIES ROLLER CHAINS
OIL-FIELD CHAINS
SUPER ROLLER CHAINS
DOUBLE CAPACITY CHAINS
S-SERIES ROLLER CHAINS
DOUBLE PITCH ROLLER CHAINS
HOLLOW-PIN CHAINS

Silver

SBR[®]

Conventional Chain

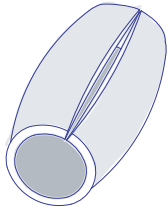

Curled Bushing

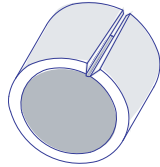

Curler Roller

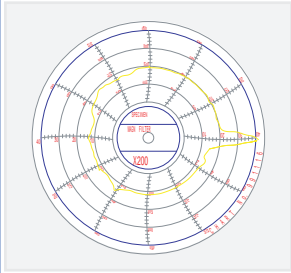

Roundness inside bushing

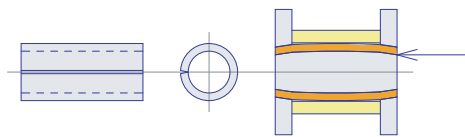
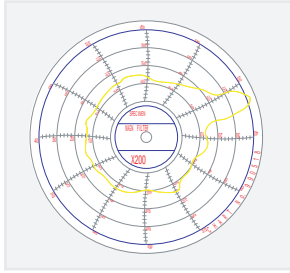

Before Assembly

After Assembly

Bushing ID becomes barrel-shape a result of press fit and makes uneven contact between pin and bushing.

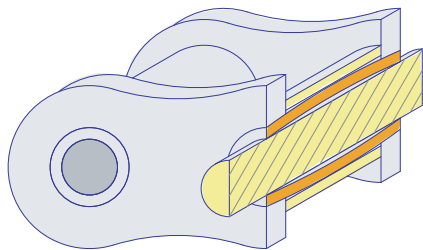

Wear areas causing elongation by barrel-shaped curled bushing.

Silver SBR Chain

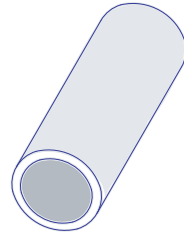

Solid Bushing

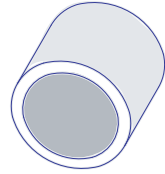

Solid Roller

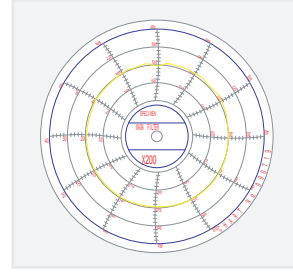

Excellent roundness inside bushing

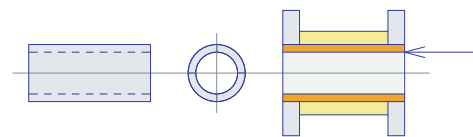

Before Assembly

After Assembly

SY solid bushing assures perfect straight ID surface after assembly.

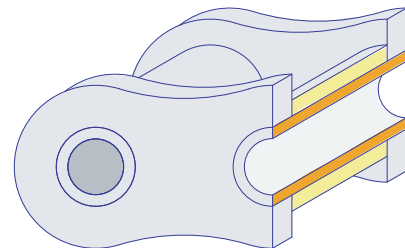

Optimal bearing surface due to perfectly cylindrical parts.



SY Chain Products Contents

Information (How to order)	8
ROLLER CHAINS	
STANDARD ROLLER CHAINS	
BS Standard Roller Chains	10
Ecological BS Style Roller Chains	15
ANSI Standard Roller Chains	16
STRAIGHT SIDEBAR CHAINS	
BS Straight Sidebar Chains	22
ANSI Straight Sidebar Chains	23
HEAVY SERIES ROLLER CHAINS	
HEAVY SERIES ROLLER CHAINS (H Series)	24
OIL-FIELD CHAINS	
Standard Series (E Series)	26
Heavy Series (HE Series)	28
SUPER ROLLER CHAINS	
Standard Series	30
Heavy Series	30
SUPER LOAD CHAINS	
Double Capacity Chains	32
S-Series Roller Chains	33
DOUBLE PITCH ROLLER CHAINS	
Drive Series	34
Conveyor Series	35
(Standard Roller Type)	35
(Carrier Roller Type)	35
RUSTLESS CHAINS	
Stainless Steel Chains (BS & ANSI)	36
SS Double Pitch Roller Chains	37
Selection of Stainless Steel Chain	38
Aqua-Proof Roller Chains (BS & ANSI)	40
Technical Information (Result of corrosion resistance test)	41
NP BS Roller Chains	42
NP ANSI Roller Chains	43
NP Double Pitch Roller Chains	44
SIDE BOW CHAINS	
SB Standard Chains	45
SB Double Pitch Chains	45
HOLLOW PIN CHAINS	
Standard Hollow Pin Chains	46
Double Pitch Hollow Pin Chains	46
Stainless Hollow Pin Chains	47
Double Pitch Stainless Hollow Pin Chains	47

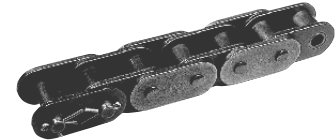

SY Chain Products Contents

MEINTENANCE FREE CHAINS

SELF LUBE CHAINS (Sinterd Steel Bushing)

Information	48
SL ANSI Standard Roller Chains	49
SL Double Pitch Roller Chains	50
SLR BS Standard Roller Chains (TS Series)	51
SLR ANSI Standard Roller Chains (TS Series)	52
SLR ANSI Standard Roller Chains (CS Series)	53
SLR Double Pitch Roller Chains	54
Hollow Pin Chains (SL Type)	55
Double Pitch Hollow Pin Chains (SL Type)	55

MAINTENANCE FREE ROLLER CHAINS

Information	56
Maintenance Free Roller Chains	57

LEAF CHAINS

AL Series	58
BL Series	59
LL Series	60
Selection of Leaf Chain	61

ATTACHMENT CHAINS

Information	62
BS Standard Attachment Chains	64
ANSI Standard Attachment Chains	66
Double Pitch Attachment Chains	68
Side Roller Chains	70
Special AA-1 Attachment Chains	70
Top Roller Chains	71
Book Binding Chain	71

ENGINEERING CHAINS

81X Series	72
3939 Attachment Chain	73

TECHNICAL INFORMATION

Trouble Shooting Hints	74
Selection of Roller Chain	76
Roller Chain quick Selection Chart	77
Selection of Stainless Steel Chain	38
Selection of Leaf Chain	61
Installation and Arrangement	78
Lubrication	79
WARNING	80
CAUTION	81
STD Horsepower Rating	82
Super Horsepower Rating	86
index	87

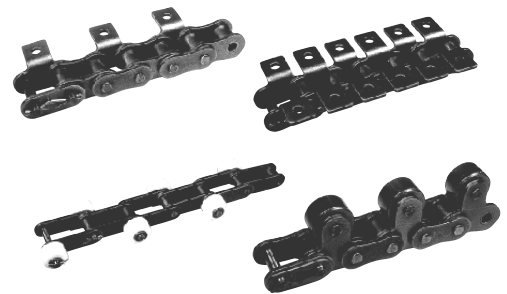

ROLLER CHAINS

DOUBLE PITCH ROLLER CHAINS

RUSTLESS CHAINS

SIDE BOW CHAINS

HOLLOW PIN CHAINS

MAINTENANCE FREE CHAINS

LEAF CHAINS

ATTACHMENT CHAINS

ENGINEERING CHAINS

TECHNICAL INFORMATION

STANDARD ROLLER CHAINS

RUN BETTER WITH SY SPECIFY YOUR REQUIREMENTS



HOW TO ORDER

Chain number, type: riveted or cottered, length and quantity are the necessary information for us to fill in your order. At the very least, the chain pitch, roller diameter and roller link inside width should be given if the chain number is unknown.

STANDARD PACKING

SY roller chains are packed for convenient handling and storing. Each 10feet length is packed in a carton. 50feet length and more are wound on reel.



specifically as possible when ordering a cut length of chain.

NOMENCLATURE

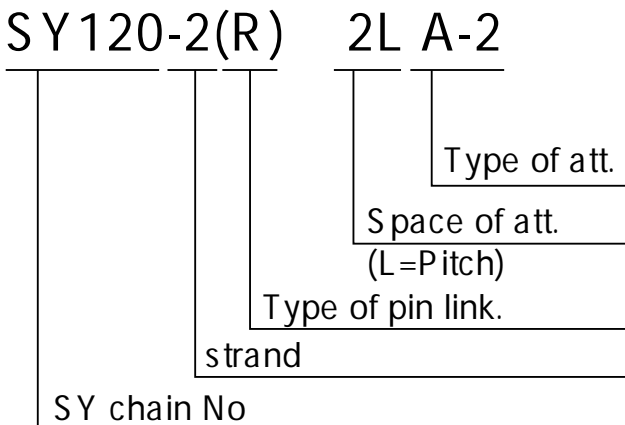

Plain chain consists of "SY chain No" and "Type of pin link". Attachment chain has one space between "Type of pin link" and "Space of attachment".

CHAIN PARTS

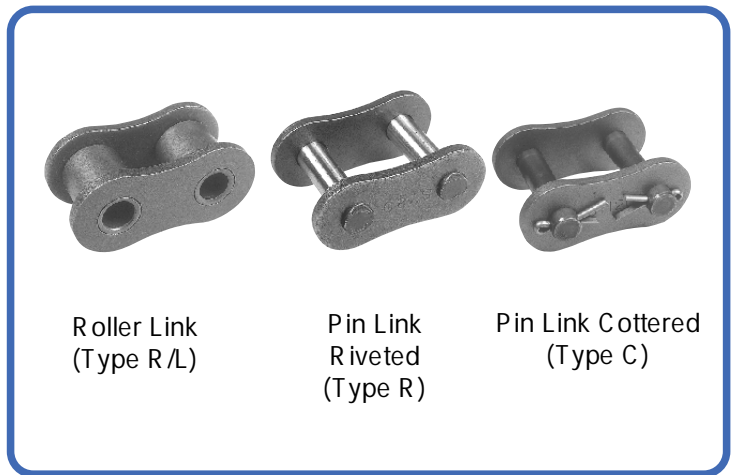

CHAIN CONNECTION PARTS

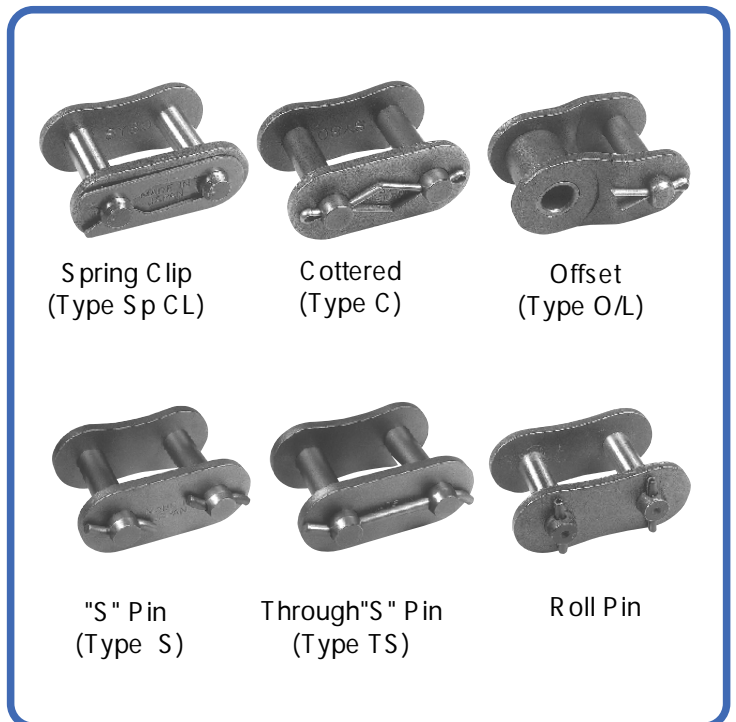

CHAIN CONSTRUCTION

RIVETED



Riveted chain is assembled by staking the pin heads on both sides of the chain

COTTERED



Cottered chain is assembled by staking the pin heads on one side of the chain and drilling a hole in the other end to accommodate a cotter pin. This type of chain is easily assembled and disassembled in the field.

SINGLE AND MULTIPLE



On multiple-strand types, all center plates are slip fitted (clearance-fitted) unless otherwise specified.

Roller chain with connecting link (C/L)

Ordinarily even number of pitches includes a C/L on one end.



Roller chain with offset link (O/L)

When an odd number of pitches is required, a C/L and an O/L are usually used.



Roller chain with connecting links (C/L's) on both ends.

For odd pitches (not endless), 2C/L's are incorporated on request.



Roller chain endless

Usually chains are furnished unendless. If an endless chain assembly is required, specify whether it is to be riveted endless or cotter-connected.

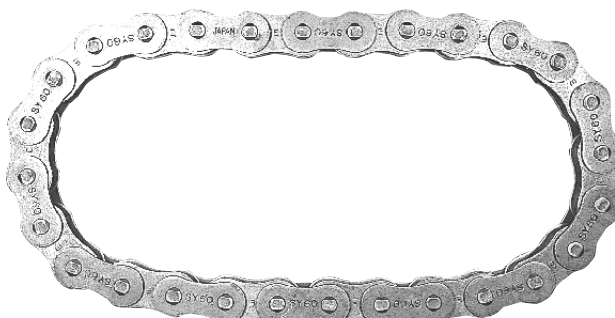

BS Standard Roller Chains

SY BS standard roller chains are standardized in accordance with ISO 606 B and fully interchangeable with chains manufactured according to BS 228 and DIN 8187.

Supplied, in rivet type, to European countries as well as replacement on machinery employing BS standard chains.

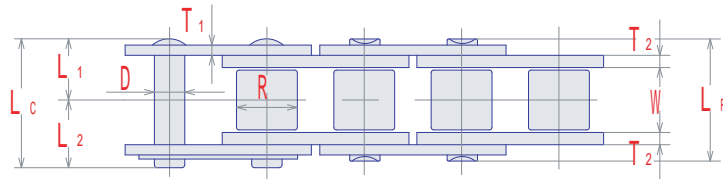

Item	See Page		
Rust Less	36	40	42
Drive Chain Selection	76	77	

Standard Packing	06B
1 Unit (10')	320P
1 Unit (5m)	526P

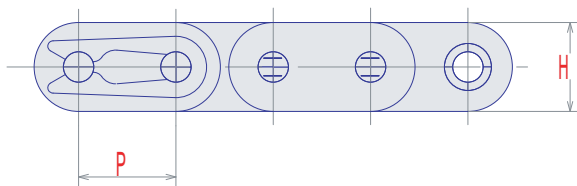
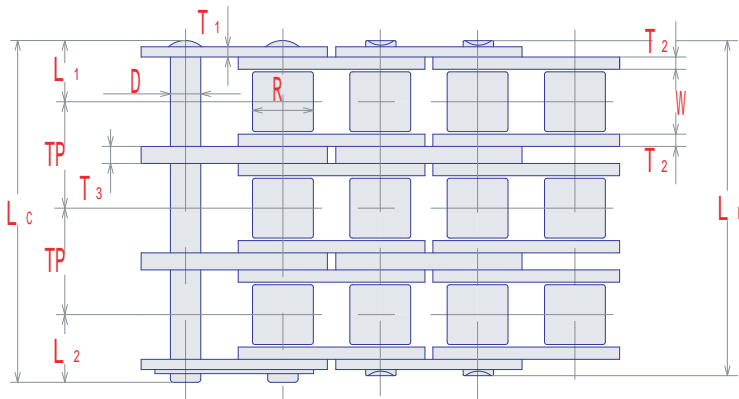

06B

SY Chain No. (B S)	Pitch	Dimensions - mm												Minimum Ultimate Strength	Maximum Allowable Load	Average Chain Weight
		Roller			Pin					Plate			Trans. Pitch			
		Width	Dia.	Dia.	Length			Height	Thickness							
P	W	R	D	LR	LC	L1	L2	H	T1	T2	T3	TP	kN	kN	kg/m	
06B	9.525	5.72	6.35	3.28	12.6	13.4	6.3	7.1	8.2	1.0	1.25	1.6	10.24	8.92	1.7	0.41
-2					22.9	23.7								16.9	2.9	0.78
-3					33.2	33.7								24.9	4.2	1.18

Curled bushing is used.

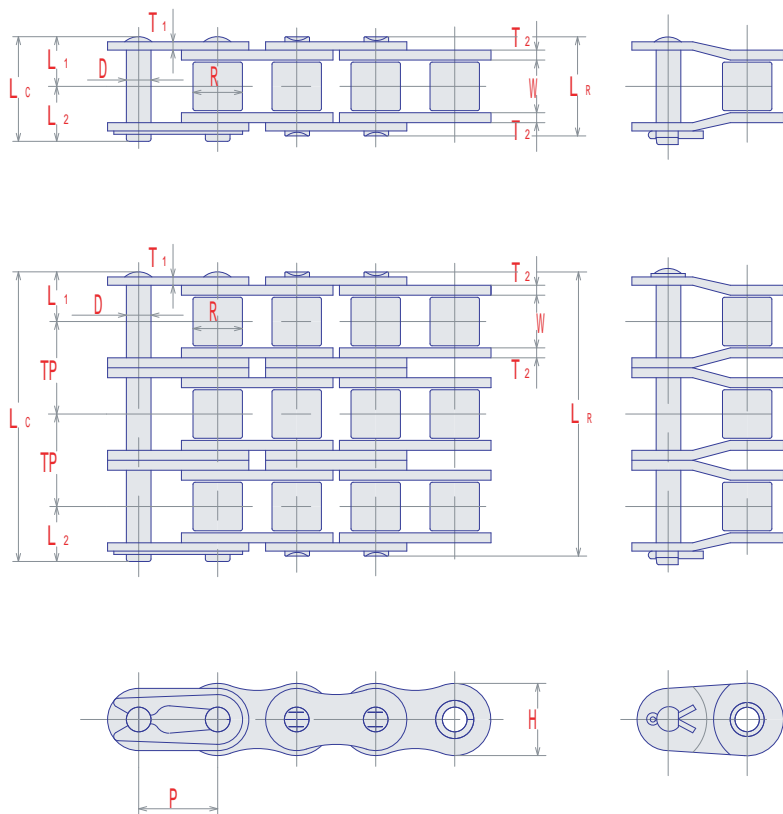

Item	See Page	
Attachment Chain	64	65
Rust Less	36	40 42
SLR Self-Lube Chain	51	
Drive Chain Selection	76	77

Standard Packing	08B	10B
1 Unit (10')	240P	192P
1 Unit (5m)	394P	316P

08B

SY Chain No. (B S)	Pitch	Dimensions - mm											Minimum Ultimate Strength	Maximum Allowable Load	Average Chain Weight
		Roller		Pin				Plate		Trans. Pitch					
		Width	Dia.	Dia.	Length		Height	Thickness							
P	W	R	D	L _R	L _C	L ₁	L ₂	H	T ₁	T ₂	TP	kN	kN	kg/m	
08B	12.70	7.75	8.51	4.45	16.7	18.0	8.4	9.6	11.8	1.5		13.92	17.8	3.14	0.61
-2					30.6	31.9							31.1	5.35	1.26
-3					44.5	45.8							44.5	7.85	1.88

10B

SY Chain No. (B S)	Pitch	Dimensions - mm											Minimum Ultimate Strength	Maximum Allowable Load	Average Chain Weight
		Roller		Pin				Plate		Trans. Pitch					
		Width	Dia.	Dia.	Length		Height	Thickness							
P	W	R	D	L _R	L _C	L ₁	L ₂	H	T ₁	T ₂	TP	kN	kN	kg/m	
10B	15.875	9.65	10.16	5.08	19.0	20.7	9.5	11.2	14.7	1.65		16.59	22.2	4.90	0.89
-2					35.6	37.3							44.5	8.33	1.79
-3					52.4	54.4							66.7	12.2	2.66

Refer to page 80. " Selection of offset link "

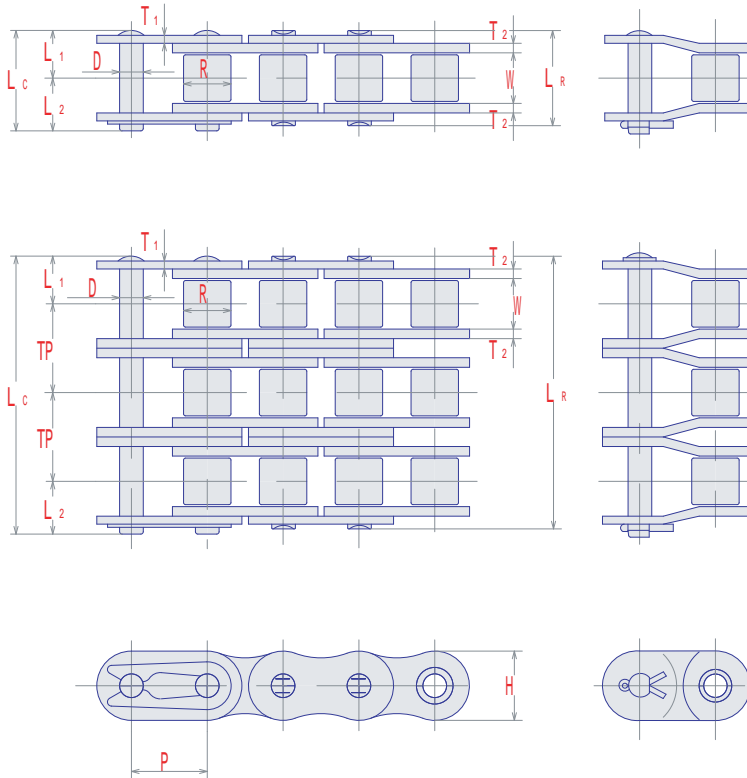

Item	See Page	
Attachment Chain	64	65
Rust Less	36	40 42
SLR Self-Lube Chain	51	
MF Maintenance Free	56	76
Drive Chain Selection	76	77

Standard Packing	12B	16B
1 Unit (10')	160P	120P
1 Unit (5m)	262P	198P

12B

SY Chain No. (B S)	Pitch	Dimensions - mm											Minimum Ultimate Strength	Maximum Allowable Load	Average Chain Weight
		Roller		Pin				Plate		Trans. Pitch					
		Width	Dia.	Dia.	Length		Height	Thickness							
P	W	R	D	LR	LC	L1	L2	H	T1	T2	TP	kN	kN	kg/m	
12B	19.05	11.68	12.07	5.72	22.0	23.6	11.0	12.6	16.1	1.8		19.46	28.9	7.06	1.14
-2					41.6	43.1							57.8	12.0	2.28
-3					61.1	62.7							86.7	17.6	3.36

16B

SY Chain No. (B S)	Pitch	Dimensions - mm											Minimum Ultimate Strength	Maximum Allowable Load	Average Chain Weight
		Roller		Pin				Plate		Trans. Pitch					
		Width	Dia.	Dia.	Length		Height	Thickness							
P	W	R	D	LR	LC	L1	L2	H	T1	T2	TP	kN	kN	kg/m	
16B	25.40	17.02	15.88	8.26	35.1	38.2	17.6	20.6	21.0	3.2	4.0	31.88	60	12.6	2.59
-2					67.2	70.1							106	21.4	5.13
-3					99.2	102.5							160	31.5	7.68

Refer to page 80. " Selection of offset link "

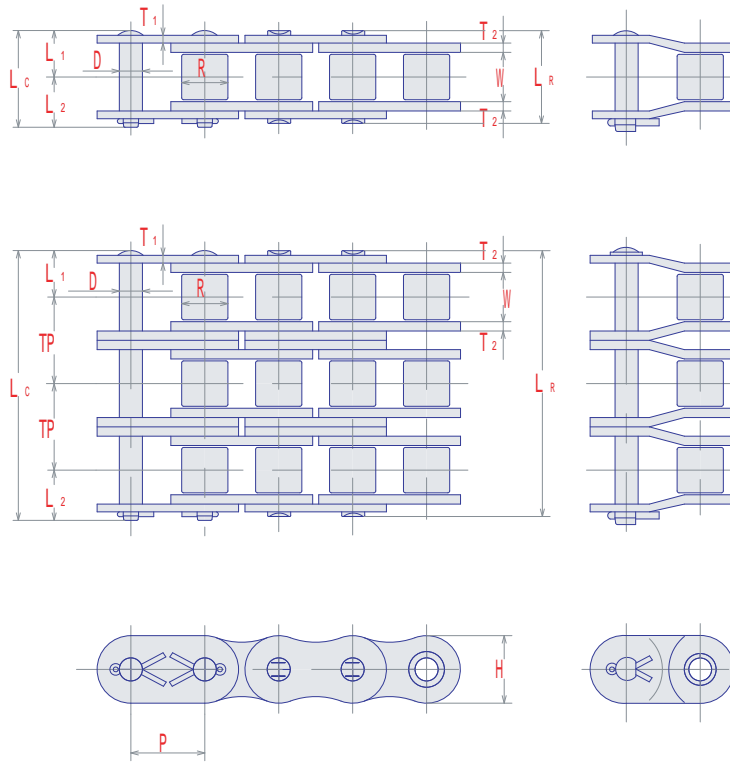

Item	See Page	
Attachment Chain	64	65
Rust Less	36	40 42
SLR Self-Lube Chain	51	
MF Maintenance Free	56	76
Drive Chain Selection	76	77

Standard Packing	20B	24B
1 Unit (10')	96P	80P
1 Unit (5m)	158P	132P

20B

SY Chain No. (B S)	Pitch	Dimensions - mm											Minimum Ultimate Strength	Maximum Allowable Load	Average Chain Weight
		Roller		Pin				Plate		Trans. Pitch					
		Width	Dia.	Dia.	Length		Height	Thickness							
P	W	R	D	L _R	L _C	L ₁	L ₂	H	T ₁	T ₂	TP	kN	kN	kg/m	
20B	31.75	19.56	19.05	10.16	40.2	44.0	20.1	23.9	26.4	3.5	4.5	36.45	95	19.6	3.76
-2					76.8	80.6							170	33.3	7.26
-3					113.3	117.2							250	49.0	10.86

24B

SY Chain No. (B S)	Pitch	Dimensions - mm											Minimum Ultimate Strength	Maximum Allowable Load	Average Chain Weight
		Roller		Pin				Plate		Trans. Pitch					
		Width	Dia.	Dia.	Length		Height	Thickness							
P	W	R	D	L _R	L _C	L ₁	L ₂	H	T ₁	T ₂	TP	kN	kN	kg/m	
24B	38.10	25.40	25.40	14.63	53.4	58.1	26.7	31.4	33.4	4.9	5.9	48.36	160	27.5	7.29
-2					101.8	106.5							280	46.8	14.53
-3					150.2	154.9							425	68.8	21.76

Refer to page 80. " Selection of offset link "

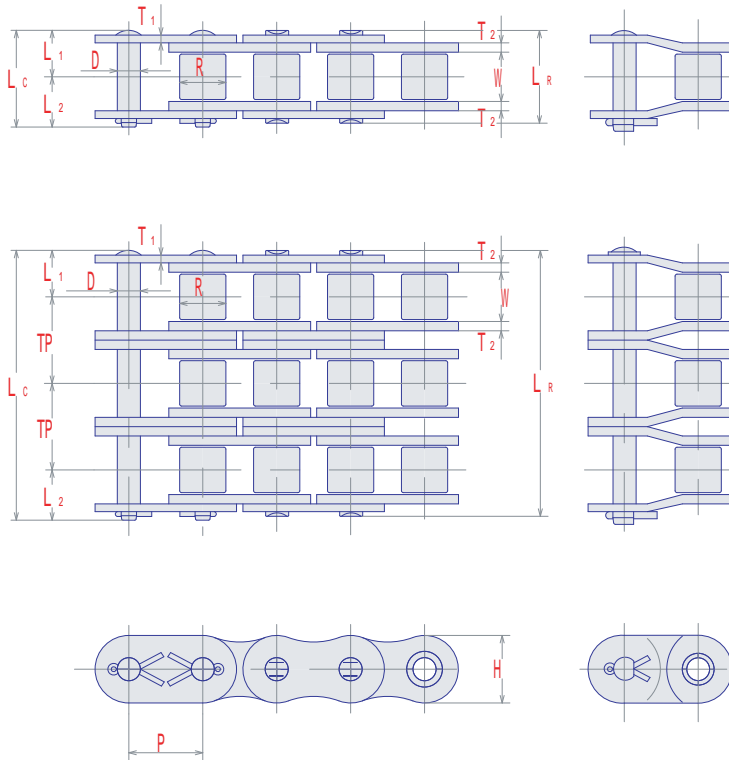

Item	See Page
Rust Less	36 40 42
SLR Self-Lube Chain	51
MF Maintenance Free	56 76
Drive Chain Selection	76 77

Standard Packing	28B	32B
1 Unit (10')	68P	60P
1 Unit (5m)	114P	100P

28B

SY Chain No. (B S)	Pitch	Dimensions - mm											Minimum Ultimate Strength	Maximum Allowable Load	Average Chain Weight
		Roller		Pin				Plate		Trans. Pitch					
		Width	Dia.	Dia.	Length		Height	Thickness							
P	W	R	D	LR	Lc	L1	L2	H	T1	T2	TP	kN	kN	kg/m	
28B	44.45	31.00	27.94	15.88	65.1	70.5	32.6	37.9	37.0	6.3	7.4	59.56	200	34.3	9.26
-2					124.7	130.0							360	58.3	18.45
-3					184.2	189.6							530	85.8	27.65

32B

SY Chain No. (B S)	Pitch	Dimensions - mm											Minimum Ultimate Strength	Maximum Allowable Load	Average Chain Weight
		Roller		Pin				Plate		Trans. Pitch					
		Width	Dia.	Dia.	Length		Height	Thickness							
P	W	R	D	LR	Lc	L1	L2	H	T1	T2	TP	kN	kN	kg/m	
32B	50.80	31.00	29.21	17.81	65.0	71.1	32.5	38.6	42.2	6.3	6.9	58.55	250	39.2	9.92
-2					123.4	129.7							450	66.6	19.76
-3					182.0	188.3							670	98.0	29.61

Refer to page 80. " Selection of offset link "

Ecological BS Style Roller Chains

- Quality is higher than BS standard chain
- Price is lower than BS standard roller chain
- It can be used BS sprocket.
- The pin diameter is different ..
- It is not possible connect with BS standard roller chain.

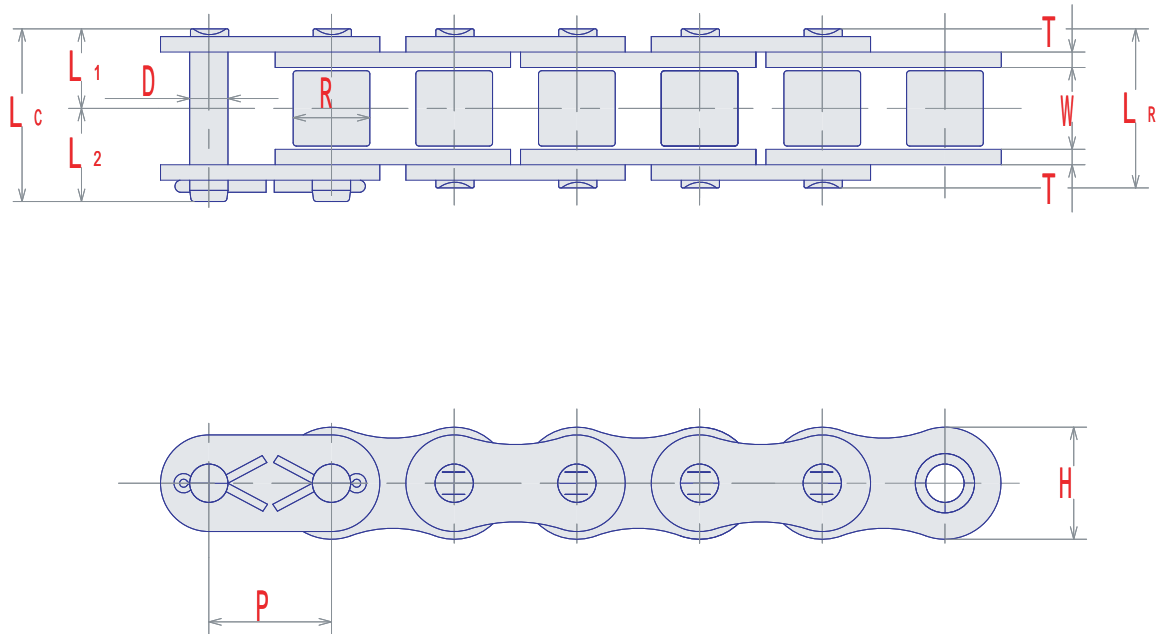

SY Chain No.	Dimensions - mm										Average Ultimate Strength kN	Maximum Allowable Load kN	Average Chain Weight kg/m
	Pitch	Roller		Pin				Plate					
		Width	Dia.	Dia.	Length			Height	Thick.				
	P	W	R	D	LR	LC	L1	L2	H	T			
EC 16B	25.40	17.1	15.88	7.93	35.8	38.5	17.9	20.6	23.4	3.2	78.5	18.4	2.52
EC 20B	31.75	19.6	19.05	9.53	41.6	45.2	20.8	24.4	29.3	4.0	118.0	28.3	3.91
EC 24B	38.10	25.4	25.40	11.10	51.8	55.7	25.9	29.8	35.1	4.8	167.0	38.0	5.76
EC 28B	44.45	31.0	27.94	12.70	61.8	66.1	30.9	35.2	40.9	5.6	216.0	50.3	7.41
EC 32B	50.80	31.6	28.58	14.28	66.6	71.0	33.3	37.7	46.7	6.4	275.0	66.3	9.79
EC 40B	63.50	38.1	39.37	19.83	82.0	90.5	41.0	49.5	59.6	8.0	451.0	82.3	16.9
EC 48B	76.20	47.5	47.63	23.78	100.0	107.7	50.0	57.7	70.3	9.5	677.0	112.8	23.6

ANSI Standard Roller Chains

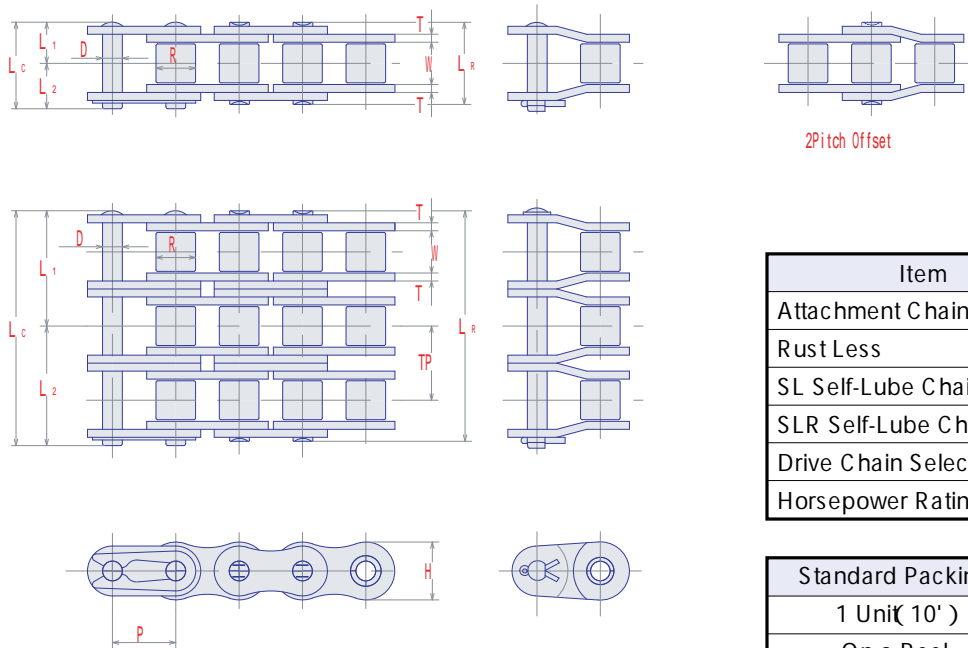

Item	See Page	
Attachment Chain	66	67
Rust Less	36	40 43
SL Self-Lube Chain	49	
SLR Self-Lube Chain	52	53
Drive Chain Selection	76	77
Horsepower Rating	82	

Standard Packing	SY35	SY40
1 Uni(10')	320P	240P
On a Reel	250'	200'

35 (BUSHED CHAIN)

SY Chain No. (ANSI)	Dimensions - mm											Average Ultimate Strength kN	Maximum Allowable Load kN	Average Chain Weight kg/m
	Pitch P	Bushing		Pin				Plate		Trans. Pitch TP				
		Width W	Dia. R	Dia. D	Length		Height H	Thick. T						
					LR	LC	L1	L2						
SY 35	9.525	4.78	5.08	3.58	12.0	12.9	6.0	6.9	9.0	1.25	-	10.8	2.48	0.34
SY 35-2					22.1	23.0	11.1	11.9			10.1	21.6	3.67	0.63
SY 35-3					32.2	33.1	16.1	17.0				32.4	5.40	0.92
SY 35-4					42.3	43.2	21.2	22.0				43.2	7.13	1.22
SY 35-5					52.4	53.2	26.2	27.0				54.0	8.42	1.56
SY 35-6					62.5	63.5	31.3	32.2				64.8	9.94	1.89

40

SY Chain No. (ANSI)	Dimensions - mm											Average Ultimate Strength kN	Maximum Allowable Load kN	Average Chain Weight kg/m
	Pitch P	Roller		Pin				Plate		Trans. Pitch TP				
		Width W	Dia. R	Dia. D	Length		Height H	Thick. T						
					LR	LC	L1	L2						
SY 40	12.70	7.95	7.92	3.96	16.5	17.9	8.3	9.6	11.7	1.5	-	19.1	4.17	0.60
SY 40-2					30.8	32.2	15.4	16.8			14.4	38.2	6.17	1.22
SY 40-3					45.0	46.6	22.5	24.1				57.3	9.08	1.85
SY 40-4					60.0	60.8	30.0	30.8				76.4	12.0	2.46
SY 40-5					74.6	75.6	37.3	38.3				95.5	14.2	3.14
SY 40-6					89.0	89.9	44.5	45.4				115.0	16.7	3.31

Refer to page 80. " Selection of offset link "

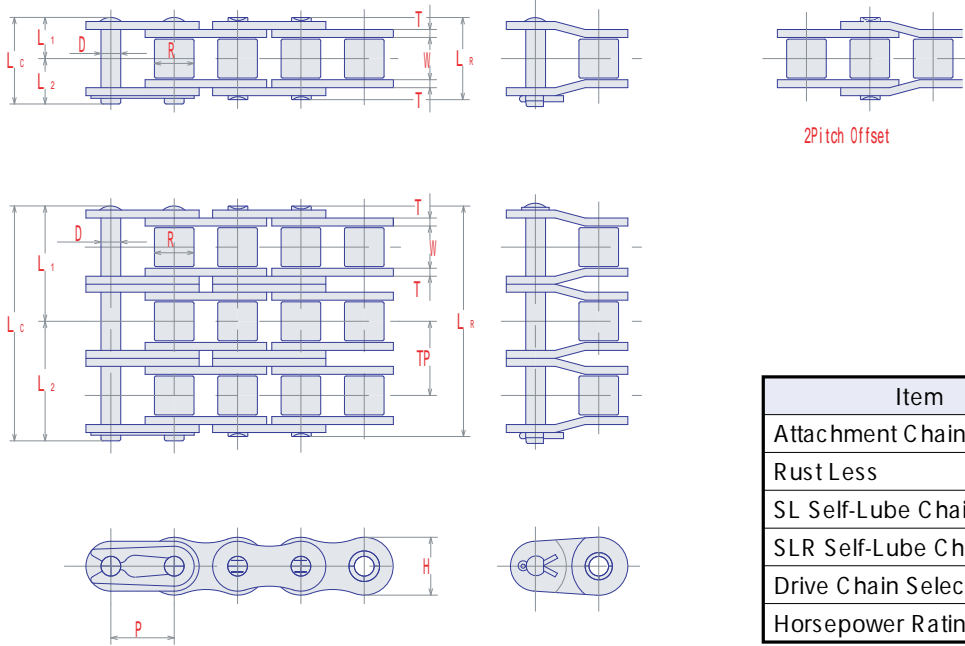

2Pitch Offset

Item	See Page	
Attachment Chain	60	67
Rust Less	36	40 43
SL Self-Lube Chain	49	
SLR Self-Lube Chain	52	53
Drive Chain Selection	76	77
Horsepower Rating	82	83

Standard Packing	SY50	SY60
1 Uni(10')	192P	160P
On a Reel	100'	100'

50

SY Chain No. (ANSI)	Dimensions - mm											Average Ultimate Strength kN	Maximum Allowable Load kN	Average Chain Weight kg/m
	Pitch P	Roller		Pin				Plate		Trans. Pitch TP				
		Width W	Dia. R	Dia. D	Length			Height H	Thick. T					
					LR	LC	L1	L2						
SY 50	15.875	9.53	10.16	5.08	20.4	22.0	10.2	11.8	14.6	2.0	-	31.9	7.22	0.98
SY 50-2					38.4	40.0	19.2	20.8			18.1	63.8	10.7	2.00
SY 50-3					56.7	58.2	28.4	29.8				95.7	15.7	3.07
SY 50-4					75.0	75.7	37.5	38.2				128.	20.7	3.97
SY 50-5					93.2	94.1	46.6	47.5				160.	24.5	5.02
SY 50-6					111.4	112.5	55.7	56.8				191.	28.9	6.01

60

SY Chain No. (ANSI)	Dimensions - mm											Average Ultimate Strength kN	Maximum Allowable Load kN	Average Chain Weight kg/m
	Pitch P	Roller		Pin				Plate		Trans. Pitch TP				
		Width W	Dia. R	Dia. D	Length			Height H	Thick. T					
					LR	LC	L1	L2						
SY 60	19.05	12.70	11.91	5.95	25.5	26.9	12.8	14.1	17.5	2.4	-	43.1	10.7	1.46
SY 60-2					48.2	49.7	24.0	25.7			22.8	86.2	14.7	2.95
SY 60-3					71.2	72.6	35.2	37.4				129	21.6	4.43
SY 60-4					94.4	95.4	47.2	48.2				172	28.5	5.92
SY 60-5					117.0	118.2	58.5	59.7				216	33.7	7.41
SY 60-6					140.0	140.9	70.1	70.8				259	39.7	8.90
SY 60-8					185.0	186.6	92.5	94.1				345	53.5	13.36
SY 60-10					230.8	232.2	115.4	116.8				431	64.7	16.34

Refer to page 80. " Selection of offset link "

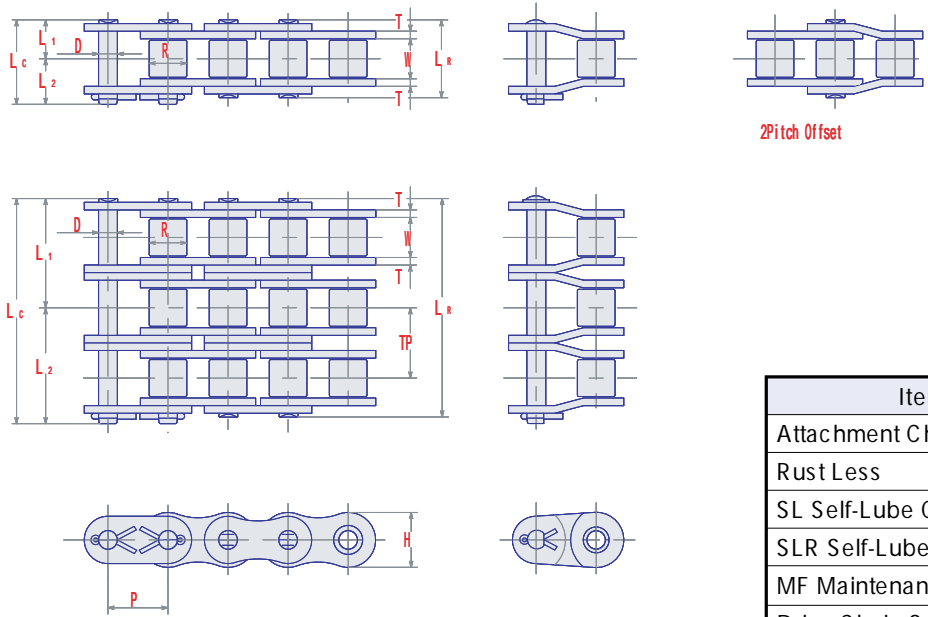

Item	See Page	
Attachment Chain	66	67
Rust Less	36	40 43
SL Self-Lube Chain	49	
SLR Self-Lube Chain	52	53
MF Maintenance Free	57	
Drive Chain Selection	76	77
Horsepower Rating	83	

Standard Packing	SY80	SY100
1 Uni(10')	120P	96P

80

SY Chain No. (ANSI)	Dimensions - mm											Average Ultimate Strength kN	Maximum Allowable Load kN	Average Chain Weight kg/m
	Pitch P	Roller		Pin				Plate		Trans. Pitch TP				
		Width W	Dia. R	Dia. D	Length		Height H	Thick. T						
				LR	LC	L1	L2							
SY80	25.40	15.88	15.88	7.93	32.8	35.5	16.4	19.1	23.4	3.2	-	78.5	18.4	2.52
SY80-2					61.6	64.5	30.8	33.7			29.3	157	25.0	5.10
SY80-3					90.9	94.1	45.5	48.6				236	36.8	7.68
SY80-4					120.4	123.5	60.2	63.3				314	48.5	10.25
SY80-5					149.8	152.8	74.9	77.9				393	57.3	12.84
SY80-6					179.1	182.1	89.6	92.5				471	67.6	15.42
SY80-8					237.6	240.6	118.8	121.8				628	91.1	20.58
SY80-10					296.2	299.2	148.1	151.1				785	110	25.81

100

SY Chain No. (ANSI)	Dimensions - mm											Average Ultimate Strength kN	Maximum Allowable Load kN	Average Chain Weight kg/m
	Pitch P	Roller		Pin				Plate		Trans. Pitch TP				
		Width W	Dia. R	Dia. D	Length		Height H	Thick. T						
				LR	LC	L1	L2							
SY100	31.75	19.05	19.05	9.53	39.4	43.0	19.7	23.3	29.3	4.0	-	118	28.3	3.91
SY100-2					75.1	78.8	37.6	41.2			35.8	236	38.4	7.74
SY100-3					110.9	114.6	55.5	59.1				354	56.5	11.58
SY100-4					147.4	150.8	73.7	77.1				472	74.6	15.40
SY100-5					183.0	186.6	91.5	95.1				590	88.1	19.26
SY100-6					218.8	222.4	109.4	113.0				708	104	23.10
SY100-8					290.4	294.1	145.2	148.9				944	140	30.81
SY100-10					362.0	365.7	181.0	184.7				1180	170	38.54

Refer to page 80. " Selection of offset link "

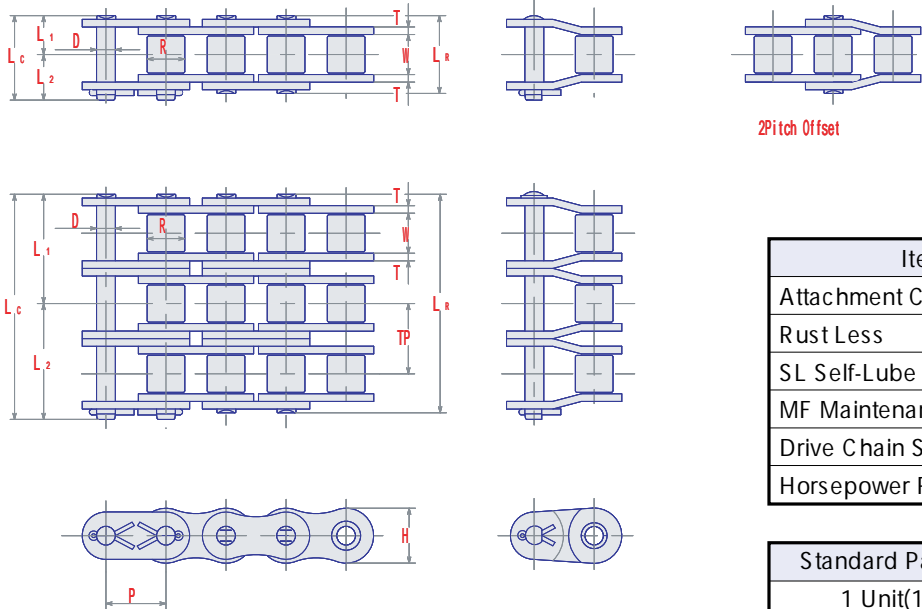

Item	See Page	
Attachment Chain	66	67
Rust Less	36	40
SL Self-Lube Chain	49	
MF Maintenance Free	57	
Drive Chain Selection	76	77
Horsepower Ratings	84	

Standard Packing	SY120	SY140
1 Unit(10')	80P	68P

120

SY Chain No. (ANSI)	Dimensions - mm											Average Ultimate Strength kN	Maximum Allowable Load kN	Average Chain Weight kg/m
	Pitch P	Roller		Pin				Plate		Trans. Pitch TP				
		Width W	Dia. R	Dia. D	Length		Height H	Thick. T						
					LR	LC			L1		L2			
SY120	38.10	25.40	22.23	11.70	49.5	53.4	24.8	28.6	35.1	4.8	-	167	38.0	5.76
SY120-2					94.9	98.8	47.5	51.3			45.4	334	51.7	11.49
SY120-3					140.3	144.2	70.2	74.0				501	76.0	17.20
SY120-4					186.1	190.0	93.1	96.9				668	100	22.92
SY120-5					231.5	235.4	115.8	119.6				835	119	28.65
SY120-6					276.9	280.8	138.5	142.3				1002	140	34.36
SY120-8					367.5	371.7	183.8	187.9				1336	188	45.81
SY120-10					458.3	462.5	229.2	233.3				1670	228	57.38

140

SY Chain No. (ANSI)	Dimensions - mm											Average Ultimate Strength kN	Maximum Allowable Load kN	Average Chain Weight kg/m
	Pitch P	Roller		Pin				Plate		Trans. Pitch TP				
		Width W	Dia. R	Dia. D	Length		Height H	Thick. T						
					LR	LC			L1		L2			
SY140	44.45	25.40	25.4	12.70	54.0	58.3	27.0	31.3	40.9	5.6	-	216	50.3	7.41
SY140-2					102.9	107.2	51.5	55.7			48.9	432	68.3	14.63
SY140-3					151.7	156.3	75.9	80.4				648	101	21.91
SY140-4					201.2	205.5	100.6	104.9				864	133	29.17
SY140-5					250.1	254.4	125.1	129.3				1080	157	36.45
SY140-6					299.0	303.3	149.5	153.8				1296	185	43.72
SY140-8					396.5	401.1	198.3	202.8				1728	249	58.28
SY140-10					494.3	498.9	247.2	251.7				2160	302	72.82

Refer to page 80. " Selection of offset link "

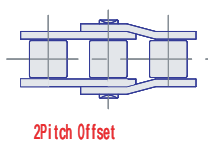
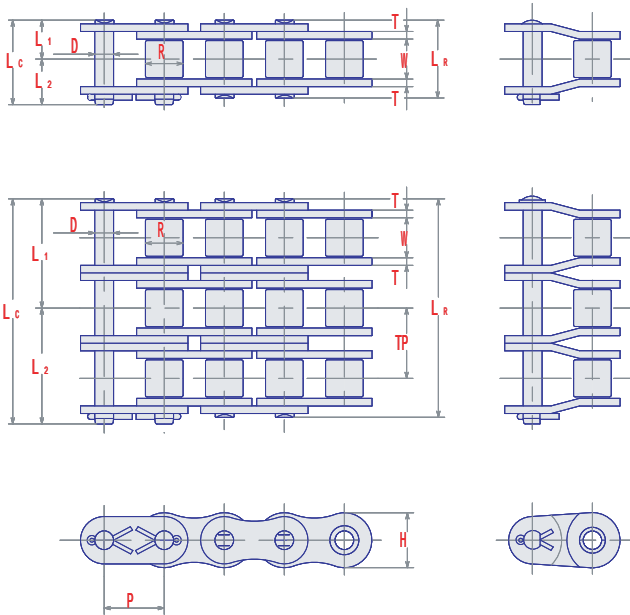

Item	See Page	
Attachment Chain	66	67
Rust Less	36	40
SL Self-Lube Chain	49	
MF Maintenance Free	57	
Drive Chain Selection	76	77
Horsepower Ratings	84	85

Standard Packing	SY160	SY180
1 Unit(10')	60P	54P

160

SY Chain No. (ANSI)	Dimensions - mm											Average Ultimate Strength kN	Maximum Allowable Load kN	Average Chain Weight kg/m
	Pitch P	Roller		Pin				Plate		Trans. Pitch TP				
		Width W	Dia. R	Dia. D	Length			Height H	Thick. T					
					LR	LC	L1	L2						
SY160	50.80	31.75	28.58	14.28	64.3	68.7	32.2	36.5	46.7	6.4	-	275	66.3	9.79
SY160-2					122.8	127.2	61.4	65.8			58.5	550	90.1	19.45
SY160-3					181.3	185.7	90.7	95.0				825	133	29.17
SY160-4					240.3	244.7	120.2	124.5				1100	175	38.77
SY160-5					298.8	303.3	149.4	153.9				1375	207	48.43
SY160-6					357.4	361.7	178.7	183.0				1650	244	58.08
SY160-8					474.4	478.8	237.2	241.6				2200	329	77.39
SY160-10					591.4	595.8	295.7	300.1				2750	398	102.86

180

SY Chain No. (ANSI)	Dimensions - mm											Average Ultimate Strength kN	Maximum Allowable Load kN	Average Chain Weight kg/m
	Pitch P	Roller		Pin				Plate		Trans. Pitch TP				
		Width W	Dia. R	Dia. D	Length			Height H	Thick. T					
					LR	LC	L1	L2						
SY180	57.15	35.70	35.70	17.45	72.5	78.4	36.3	42.1	52.5	7.2	-	353	70.6	13.39
SY180-2					138.2	144.0	69.1	74.9			65.8	706	98.4	26.62
SY180-3					204.5	210.2	102.3	107.9				1059	145	39.85
SY180-4					270.2	275.9	135.1	140.8				1412	191	53.08
SY180-5					336.0	341.6	173.6	173.7				1765	226	66.31
SY180-6					401.8	407.3	200.9	206.4				2118	266	79.54

Refer to page 80. " Selection of offset link "

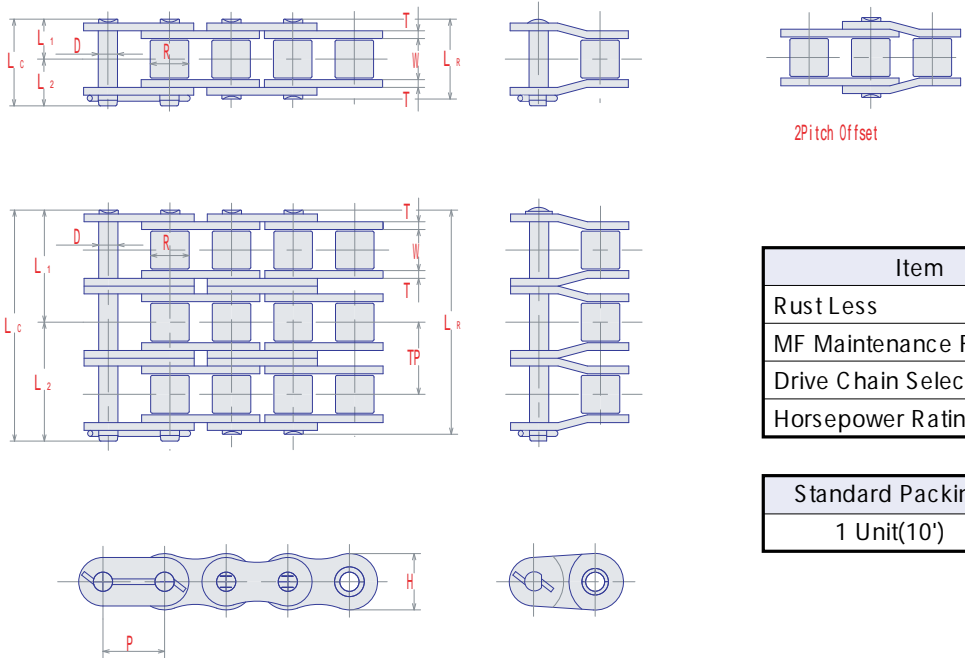

Item	See Page	
Rust Less	40	
MF Maintenance Free	57	
Drive Chain Selection	76	77
Horsepower Ratings	85	

Standard Packing	SY200	SY240
1 Unit(10')	48P	40P

200

SY Chain No. (ANSI)	Dimensions - mm											Average Ultimate Strength kN	Maximum Allowable Load kN	Average Chain Weight kg/m
	Pitch P	Roller		Pin				Plate		Trans. Pitch TP				
		Width W	Dia. R	Dia. D	Length			Height H	Thick. T					
					LR	LC	L1	L2						
SY200	63.50	38.10	39.67	19.83	78.5	87.0	39.3	47.7	59.8	8.0	-	451	82.3	16.93
SY200-2					150.2	158.7	75.1	83.6			71.6	902	122	33.73
SY200-3					221.7	230.2	110.9	119.3				1353	179	50.53
SY200-4					293.3	302.4	146.7	155.7				1804	236	67.34
SY200-5					365.5	374.0	182.8	191.2				2255	279	84.14
SY200-6					437.1	445.6	218.6	227.0				2706	329	100.94

240

SY Chain No. (ANSI)	Dimensions - mm											Average Ultimate Strength kN	Maximum Allowable Load kN	Average Chain Weight kg/m
	Pitch P	Roller		Pin				Plate		Trans. Pitch TP				
		Width W	Dia. R	Dia. D	Length			Height H	Thick. T					
					LR	LC	L1	L2						
SY240	76.20	47.63	47.63	23.78	96.4	104.1	48.2	55.9	70.3	9.5	-	677	112.8	23.64
SY240-2					184.2	191.8	92.1	99.7			87.8	1354	167	47.13
SY240-3					272.0	279.6	136.0	143.6				2031	245	70.61
SY240-4					359.8	367.4	179.9	187.5				2708	324	94.09
SY240-5					447.6	455.2	223.8	231.4				3385	383	117.56
SY240-6					535.5	543.0	267.8	275.2				4062	451	141.06

Refer to page 80. " Selection of offset link "

BS Straight Sidebar Chains

SY BS straight sidebar chains are identical with BS standard chains except for the straight side plates. Provided with higher fatigue resistance than the standard chains.

Sprockets for BS standard chains may be used for these chains. For identification, a suffix of F is added to the standard chain numbers as listed below.

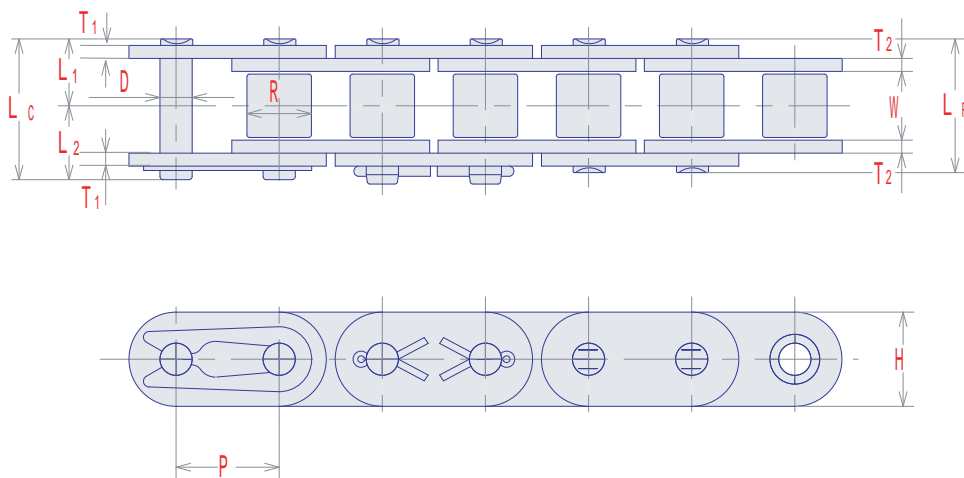

SY Chain No.	Dimensions - mm												Minimum Ultimate Strength	Maximum Allowable Load	Average Chain Weight	Type of Conn Link
	Pitch	Roller		Pin				Plate		Trans. Pitch						
		Width	Dia.	Dia.	Length			Height	Thickness							
P	W	R	D	LR	Lc	L1	L2	H	T1	T2	TP	kN	kN	kg/m		
06B-F	9.525	5.72	6.35	3.28	12.6	13.4	6.3	7.1	8.2	1.0	1.25	8.92	8.92	1.77	0.48	Spcl
08B-F	12.70	7.75	8.51	4.45	16.7	18.0	8.4	9.6	11.8	1.5		17.8	17.8	3.14	0.68	
10B-F	15.875	9.65	10.16	5.08	19.0	20.7	9.5	11.2	14.7	1.65		22.3	22.3	4.90	0.99	
12B-F	19.05	11.68	12.07	5.72	22.0	23.6	11.0	12.6	16.1	1.8		28.9	28.9	7.06	1.27	
16B-F	25.40	17.02	15.88	8.26	35.1	38.2	17.6	20.5	20.3	3.2	4.0	60.8	60.8	12.6	2.9	C
20B-F	31.75	19.56	19.05	10.16	40.2	44.0	20.1	23.9	26.0	3.5	4.5	95.1	95.1	19.6	4.21	
24B-F	38.10	25.40	25.40	14.63	53.4	58.1	26.7	31.4	33.4	4.8	5.9	161.0	161.0	27.5	8.16	
28B-F	44.45	30.99	27.94	15.88	65.1	70.5	32.6	37.9	36.6	6.3	7.4	201.0	201.0	34.3	10.37	
32B-F	50.80	30.99	29.21	17.81	65.0	71.1	32.5	38.6	41.7	6.3	6.9	250.0	250.0	39.2	11.11	

ANSI Straight Sidebar Chains

SY ANSI straight sidebar chains are identical with ANSI standard chains except for the straight side plates. Provided with higher fatigue resistance than the standard chains.

Sprockets for ANSI standard chains may be used for these chains. For identification, a suffix of F is added to the standard chain numbers as listed below.

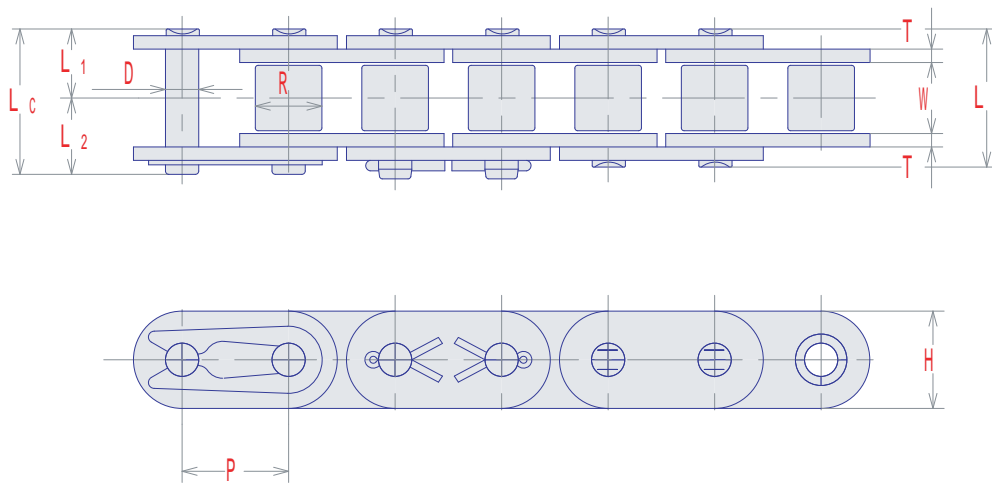

SY Chain No.	Dimensions - mm										Average Ultimate Strength	Maximum Allowable Load	Average Chain Weight	Type of Conn Link
	Pitch	Roller		Pin				Plate						
		Width	Dia.	Dia.	Length			Height	Thick.					
P	W	R	D	LR	LC	L1	L2	H	T	kN	kN	kg/m		
SY 35F	9.525	4.78	5.08	3.58	12.0	12.9	6.0	6.9	9.0	1.25	10.8	2.23	0.38	Spcl
SY 40F	12.70	7.95	7.92	3.96	16.5	17.7	8.3	9.4	11.7	1.5	19.1	4.17	0.67	
SY 50F	15.875	9.53	10.16	5.08	20.4	21.9	10.2	11.7	14.6	2.0	31.9	7.22	1.1	C
SY 60F	19.05	12.70	11.91	5.95	25.5	26.9	12.8	14.1	17.5	2.4	43.1	10.7	1.63	
SY 80F	25.40	15.88	15.88	7.93	32.8	35.0	16.4	18.6	23.4	3.2	78.5	18.4	2.82	
SY 100F	31.75	19.05	19.05	9.53	39.4	43.0	19.7	23.3	29.3	4.0	118	28.3	4.37	
SY 120F	38.10	25.40	22.23	11.1	49.5	53.4	24.8	28.6	35.1	4.8	167	38.0	6.45	
SY 140F	44.45	25.40	25.40	12.7	54.0	58.3	27.0	31.3	40.9	5.6	216	50.3	8.29	
SY 160F	50.80	31.75	28.58	14.28	64.3	68.7	32.2	36.5	46.7	6.4	275	66.3	10.96	
SY 200F	63.50	38.1	39.67	19.83	78.5	87.0	39.3	47.7	59.8	8.0	451	82.3	18.96	
SY 240F	76.20	47.63	47.63	23.78	96.4	104.1	48.2	55.9	70.3	9.5	677	112.8	26.47	

Heavy Series Roller Chains (H Series)

SY H-series roller chains are provided with greater shock and wear resistance and high breaking strength for general purpose applications. The side plate thickness is equal to the next larger ANSI roller chains and through-hardened high-tensile structural steel pins realize strong power transmission in limited equipment space, showing excellent shock absorption and fatigue strength and high ultimate strength of as much as 110-120 percent.

Single roller chains of this series run on standard single roller chain sprockets.

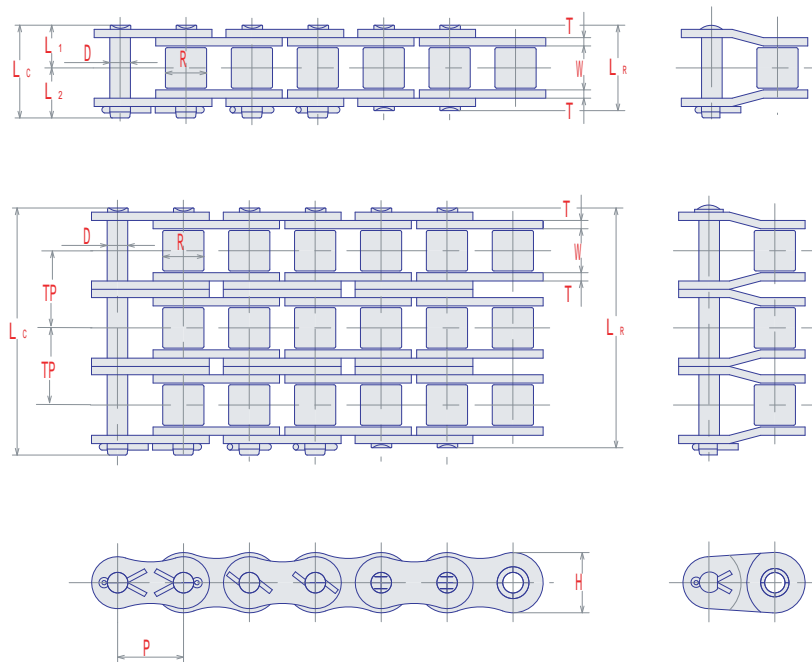

SINGLE STRANDS

SY Chain No.	Dimensions - mm										Average Ultimate Strength	Maximum Allowable Load	Average Chain Weight	Type of Conn Link
	Pitch	Roller		Pin				Plate						
		Width	Dia.	Dia.	Length		Height	Thick.						
P	W	R	D	L _R	L _C	L ₁	L ₂	H	T	kN	kN	kg/m		
SY 60H	19.05	12.70	11.91	5.95	28.8	30.8	14.4	16.4	17.5	3.2	54.9	10.7	1.80	C
SY 80H	25.40	15.88	15.88	7.93	35.7	38.7	17.9	20.8	23.4	4.0	90.2	18.4	2.81	
SY100H	31.75	19.05	19.05	9.53	42.4	45.9	21.2	24.7	29.3	4.8	137	28.3	4.14	
SY120H	38.10	25.40	22.23	11.10	52.8	57.2	26.4	30.8	35.1	5.6	186	38.0	5.83	
SY140H	44.45	25.40	25.40	12.70	57.2	61.8	28.6	33.2	40.9	6.4	241	50.3	8.41	
SY160H	50.80	31.75	28.58	14.28	67.9	73.0	34.0	39.0	46.7	7.2	306	66.3	10.86	
SY180H	57.15	35.70	35.70	17.45	75.6	81.5	37.8	43.7	52.5	8.0	373	70.6	15.18	
SY200H	63.50	38.10	39.67	19.83	84.8	93.4	42.4	51.0	59.8	9.5	520	82.3	17.85	
SY240H	76.20	47.63	47.63	23.78	109.8	118.2	54.9	63.3	70.3	12.7	726	112.8	32.29	

Refer to page 80. " Selection of offset link "

MULTIPLE STRANDS

SY Chain No.	Dimensions - mm											Average Ultimate Strength kN	Maximum Allowable Load kN	Average Chain Weight kg/m
	Pitch	Roller		Pin				Plate		Trans. Pitch				
		Width	Dia.	Dia.	Length			Height	Thick.					
	P	W	R	D	LR	LC	L1	L2	H	T	TP			
SY 60H-2	19.05	12.70	11.91	5.95	54.9	57.0	27.4	29.6	17.5	3.2	26.1	110	15.2	3.59
SY 60H-3					80.6	83.1	40.3	42.8				165	22.3	5.39
SY 60H-4					107.1	109.3	53.6	55.7				220	29.4	7.18
SY 80H-2	25.40	15.88	15.88	7.93	68.4	71.3	34.2	37.1	23.4	4.0	32.6	180	25.8	5.54
SY 80H-3					101.0	104.0	50.5	53.5				271	38.0	8.26
SY 80H-4					133.6	136.7	66.8	69.9				361	50.2	10.98
SY 80H-5					166.2	169.3	83.1	86.2				451	59.3	13.71
SY 80H-6					198.8	201.9	99.4	102.5				541	69.9	16.43
SY 80H-8					264.0	267.1	132.0	135.1				722	94.2	21.88
SY100H-2	31.75	19.05	19.05	9.53	81.6	85.0	40.8	44.2	29.3	4.8	39.1	274	39.1	8.20
SY100H-3					120.7	124.4	60.4	64.0				414	57.5	12.26
SY100H-4					159.4	163.2	79.7	83.5				548	75.9	16.33
SY100H-5					198.5	202.3	99.3	103.0				685	89.7	20.39
SY100H-6					238.2	241.8	119.1	122.7				822	106	24.45
SY100H-8					316.4	320.0	158.2	161.8				1096	143	32.58
SY100H-10					394.6	398.2	197.3	200.9				1370	173	40.70
SY120H-2	38.10	25.40	22.23	11.10	102.0	106.1	51.0	55.1	35.1	5.6	48.9	372	53.4	11.56
SY120H-3					150.6	154.6	75.3	79.3				558	78.5	17.29
SY120H-4					199.2	203.2	99.6	103.6				744	104	23.02
SY120H-5					247.8	252.6	123.9	128.7				930	123	28.75
SY120H-6					297.6	301.9	148.8	153.1				1116	144	34.48
SY120H-8					395.4	399.7	197.7	202.0				1488	195	45.94
SY120H-10					493.2	497.5	246.6	250.9				1860	236	57.40
SY140H-2	44.45	25.40	25.40	12.70	109.4	114.0	54.7	59.3	40.9	6.4	52.2	482	70.0	16.59
SY140H-3					161.8	166.4	80.9	85.5				723	103	24.77
SY140H-4					214.0	218.7	107.0	111.7				964	136	32.96
SY140H-5					266.2	270.9	133.1	137.8				1205	161	41.15
SY140H-6					318.4	323.1	159.2	163.9				1446	190	49.33
SY140H-8					422.8	427.5	211.4	216.1				1928	255	65.78
SY160H-2	50.8	31.75	28.58	14.28	129.8	134.9	64.9	70.0	46.7	7.2	61.9	612	93.3	21.21
SY160H-3					191.8	196.8	95.9	100.9				918	137	31.54
SY160H-4					253.7	258.8	126.9	131.9				1224	181	41.89
SY160H-6					377.5	382.6	188.8	193.8				1836	253	62.58
SY180H-2	57.15	35.70	35.70	17.45	144.2	149.8	72.1	77.7	52.5	8.0	68.6	746	102	31.06
SY180H-3					212.8	218.7	106.4	112.3				1119	149	44.94
SY180H-4					281.4	287.4	140.7	146.7				1492	197	59.83
SY200H-2	63.50	38.10	39.67	19.84	163.1	172.0	81.6	90.4	59.8	9.5	78.3	1040	127	35.20
SY200H-3					241.4	250.3	120.7	129.6				1560	186	62.53
SY200H-4					319.8	328.4	159.9	168.7				2080	246	69.94
SY240H-2	76.20	47.63	47.63	23.78	211.0	219.4	105.5	113.9	70.3	12.7	101.2	1452	173	62.06
SY240H-3					312.2	320.6	156.1	164.5				2178	255	91.82
SY240H-4					413.4	421.8	206.7	215.1				2904	336	121.58

Oil-Field Chains (E Series)

ROLLER CHAINS

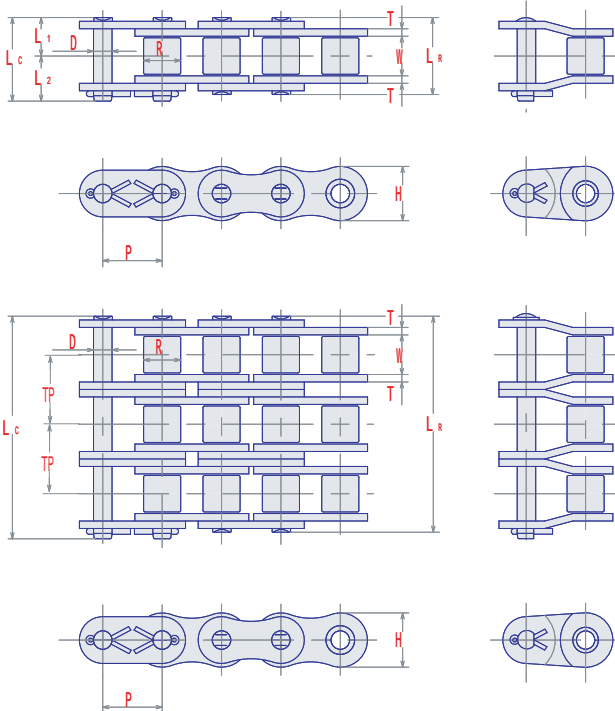

SY Oil-field chains are manufactured in accordance with ANSI, API standards, and officially approved by The American Petroleum Institute for high quality, reliability and long trouble-free service life. Used in oil-field drilling and producing operations such as hoisting, pumping and drawworks.

SY E & HE-series roller chains are manufactured in the same standards as Oil-field chains.

E TYPE

SY Chain No.	Dimensions - mm											Average Ultimate Strength kN	Maximum Allowable Load kN	Average Chain Weight kg/m
	Pitch P	Roller		Pin Dia. D	Pin Length				Plate		Trans. Pitch TP			
		Width W	Dia. R		LR	LC	L1	L2	Height H	Thick. T				
SY 80E	25.4	15.88	15.88	7.93	32.8	35.5	16.4	19.1	23.4	3.2	-	79.4	18.4	2.52
SY 80E-2					61.6	64.5	30.8	33.7			29.3	159	26.7	5.10
SY 80E-3					90.9	94.1	45.5	48.6				238	39.3	7.68
SY 80E-4					120.4	123.5	60.2	63.3				318	51.8	10.25
SY 80E-5					149.8	152.8	74.9	77.9				397	61.2	12.84
SY 80E-6					179.1	182.1	89.6	92.5				476	72.2	15.42
SY 80E-8					237.6	240.6	118.8	121.8				635	97.3	20.58
SY100E	31.75	19.05	19.05	9.53	39.4	43.0	19.7	23.3	29.3	4.0	-	119	28.3	3.91
SY100E-2					75.1	78.8	37.6	41.2			35.8	238	40.8	7.74
SY100E-3					110.9	114.6	55.5	59.1				357	60.0	11.58
SY100E-4					147.4	150.8	73.7	77.1				476	79.2	15.40
SY100E-5					183.0	186.6	91.5	95.1				595	93.6	19.26
SY100E-6					218.8	222.4	109.4	113.0				714	110	23.10
SY100E-8					290.4	294.1	145.2	148.9				952	149	30.81
SY100E-10					362.0	365.7	181.0	184.7				1190	180	38.54
SY120E	38.10	25.40	22.23	11.10	49.5	53.4	24.8	28.6	35.1	4.8	-	174	38.0	5.76
SY120E-2					94.9	98.8	47.5	51.3			45.4	348	54.2	11.49
SY120E-3					140.3	144.2	70.2	74.0				522	79.8	17.20
SY120E-4					186.1	190.0	93.1	96.9				696	105	22.92
SY120E-5					231.5	235.4	115.8	119.6				870	124	28.65
SY120E-6					276.9	280.8	138.5	142.3				1044	147	34.36
SY120E-8					367.5	371.7	183.8	187.9				1392	198	45.81
SY120E-10					458.3	462.5	229.2	233.3				1740	239	57.38

Refer to page 80. " Selection of offset link "

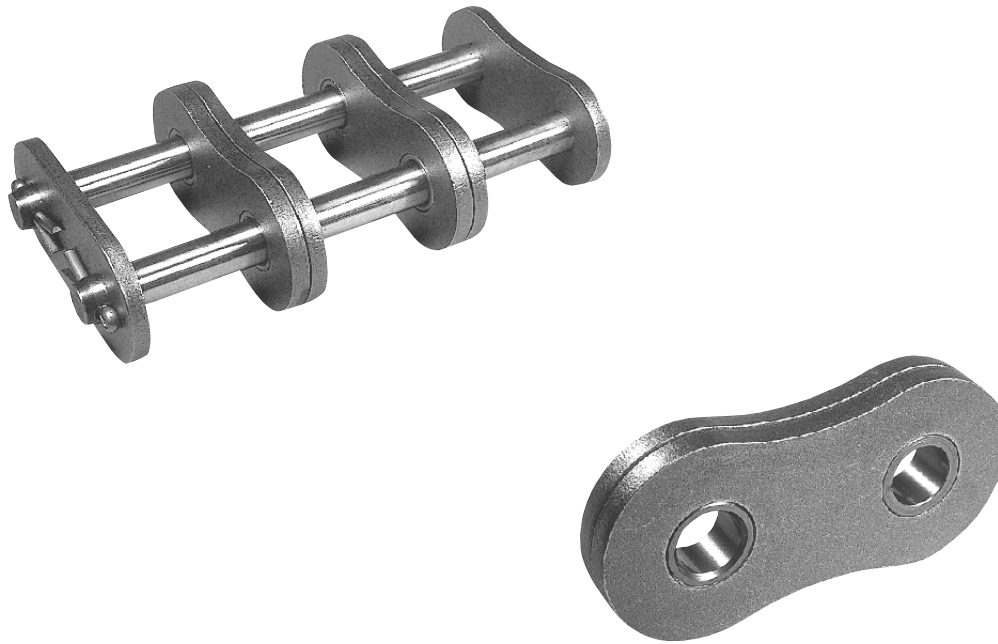

BCL Connecting links provided with press-fit chains

SY Chain No.	Dimensions - mm											Average Ultimate Strength kN	Maximum Allowable Load kN	Average Chain Weight kg/m
	Pitch P	Roller		Pin				Plate		Trans. Pitch TP				
		Width W	Dia. R	Dia. D	Length				Height H		Thick. T			
					LR	LC	L1	L2						
SY140E	44.45	25.40	25.40	12.70	54.0	58.3	27.0	31.3	40.9	5.6	-	227	50.3	7.41
SY140E-2					102.9	107.2	51.5	55.7			48.9	454	73.2	14.63
SY140E-3					151.7	156.3	75.9	80.4				681	108	21.91
SY140E-4					201.2	205.5	100.6	104.9				908	142	29.17
SY140E-5					250.1	254.4	125.1	129.3				1135	168	36.45
SY140E-6					299.0	303.3	149.5	153.8				1362	198	43.72
SY140E-8					396.5	401.1	198.3	202.8				1816	267	58.28
SY160E	50.80	31.75	28.58	14.28	64.3	68.7	32.2	36.5	46.7	6.4	-	294	66.3	9.79
SY160E-2					122.8	127.2	61.4	65.8			58.5	588	95.0	19.45
SY160E-3					181.3	185.7	90.7	95.0				882	140	29.17
SY160E-4					240.3	244.7	120.2	124.5				1176	184	38.77
SY160E-6					298.8	303.3	149.4	153.9				1764	257	58.08
SY180E	57.15	35.70	35.70	17.45	72.5	78.4	36.3	42.1	52.5	7.2	-	363	70.6	13.39
SY180E-2					138.2	144.0	69.1	74.9			65.8	726	102	26.62
SY180E-3					204.5	210.2	102.3	107.9				1089	150	39.85
SY180E-4					270.2	275.9	135.1	140.8				1452	197	53.08
SY200E	63.50	38.10	39.67	19.83	78.5	87.0	39.3	47.7	59.8	8.0	-	470	82.3	16.93
SY200E-2					150.2	158.7	75.1	83.6			71.6	940	130	33.73
SY200E-3					221.7	230.2	110.9	119.3				1410	191	50.53
SY200E-4					293.3	302.4	146.7	155.7				1880	252	67.34
SY240E	76.20	47.63	47.63	23.78	96.4	104.1	48.2	55.9	70.3	9.5	-	677	112.8	23.64
SY240E-2					184.2	191.8	92.1	99.7			87.8	1354	179	47.13
SY240E-3					272.0	279.6	136.0	143.6				2031	263	70.61
SY240E-4					359.8	367.4	179.9	187.5				2708	347	94.09

OIL-FIELD CHAINS(HE SERIES)

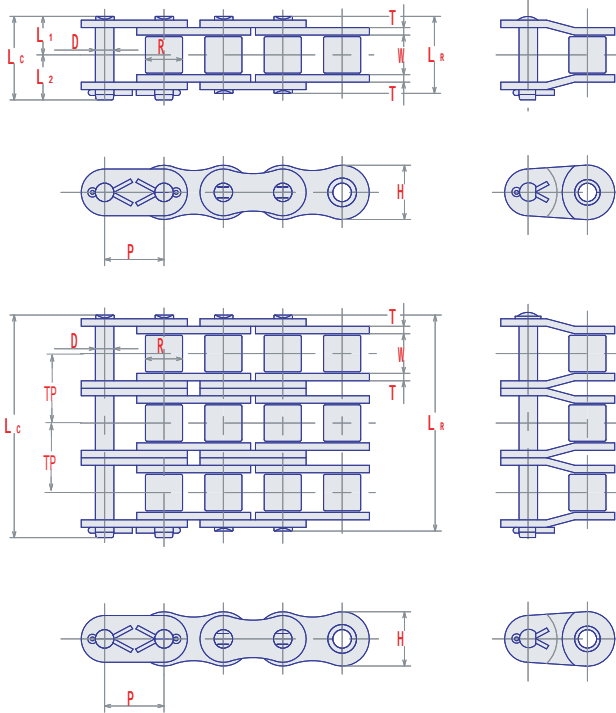

SY Heavy series roller chains are designed with thicker side plates to insure greater capacity for absorbing shock loads without fatigue failure of side plates. Also manufactured to close tolerances in accordance with ANSI specifications and are mainly used for applications where space and design limitations prohibit the use of a large size roller chain, and yet greater load carrying capacities are needed in oil-field drilling operations.

HE TYPE

SY Chain No.	Dimensions - mm											Average Ultimate Strength kN	Maximum Allowable Load kN	Average Chain Weight kg/m
	Pitch P	Roller		Pin				Plate		Trans. Pitch TP				
		Width W	Dia. R	Dia. D	Length		Height H	Thick. T						
					L _R	L _C	L ₁	L ₂						
SY 80HE	25.4	15.88	15.88	7.93	35.5	38.8	17.8	21.1	23.4	4.0	-	93.2	18.4	2.80
SY 80HE-2					68.4	71.3	34.2	37.1			32.6	186	28.4	5.54
SY 80HE-3					101.0	104.0	50.5	53.5				280	41.8	8.26
SY 80HE-4					133.6	136.7	66.8	69.9				373	55.1	10.98
SY 80HE-5					166.2	169.3	83.1	86.2				466	65.1	13.71
SY 80HE-6					199.0	201.9	99.4	102.5				559	76.8	16.43
SY 80HE-8					264.0	267.1	132.0	135.1				746	104	21.88
SY100HE	31.75	19.05	19.05	9.53	42.2	45.7	21.1	24.6	29.3	4.8	-	142	28.3	4.14
SY100HE-2					81.6	85.0	40.8	44.2			39.1	284	45.1	8.20
SY100HE-3					120.7	124.4	60.4	64.0				426	66.3	12.26
SY100HE-4					159.0	163.5	79.7	83.5				568	87.5	16.33
SY100HE-5					198.5	202.3	99.3	103.0				710	103	20.39
SY100HE-6					238.2	241.8	119.1	122.7				852	122	24.45
SY100HE-8					316.4	320.0	158.2	161.8				1136	164	32.58
SY100HE-10					394.6	398.2	197.3	200.9				1420	199	40.70
SY120HE	38.10	25.40	22.23	11.10	52.6	57.0	26.3	30.7	35.1	5.6	-	191	38.0	5.83
SY120HE-2					102.0	106.1	51.0	55.1			48.9	382	58.3	11.56
SY120HE-3					150.6	154.6	75.3	79.3				573	85.8	17.29
SY120HE-4					199.2	203.7	99.6	104.1				764	113	23.02
SY120HE-5					247.8	252.6	123.9	128.7				955	134	28.75
SY120HE-6					297.6	301.5	148.8	152.7				1146	158	34.48
SY120HE-8					395.4	399.7	197.7	202.0				1528	213	45.94
SY120HE-10					493.2	497.5	246.6	250.9				1910	257	57.40

Refer to page 80. " Selection of offset link "

SY Chain No.	Dimensions - mm											Average Ultimate Strength kN	Maximum Allowable Load kN	Average Chain Weight kg/m
	Pitch	Roller		Pin				Plate		Trans. Pitch				
		Width	Dia.	Dia.	Length		Height	Thick.						
		P	W	R	D	LR	LC	L1	L2		H			
SY140HE	44.45	25.40	25.40	12.70	57.0	61.6	28.5	33.1	40.9	6.4	52.2	252	50.3	8.41
SY140HE-2					109.4	114.0	54.7	59.3				504	76.7	16.59
SY140HE-3					161.8	166.4	80.9	85.5				756	113	24.77
SY140HE-4					214.0	218.7	107.0	111.7				1008	149	32.96
SY140HE-5					266.2	270.9	133.1	137.8				1260	176	41.15
SY140HE-6					318.4	323.1	159.2	163.9				1512	207	49.33
SY140HE-8					422.8	427.5	211.4	216.1				2016	280	65.78
SY160HE	50.80	31.75	28.58	14.28	67.7	72.9	33.9	39.1	46.7	7.2		61.9	319	66.3
SY160HE-2					129.8	134.9	64.9	70.0			638		100.	21.21
SY160HE-3					191.8	196.8	95.9	100.9			957		147	31.54
SY160HE-4					253.7	258.8	126.9	131.9			1276		194	41.89
SY160HE-6					377.5	382.6	188.8	193.8			1914		270	62.58
SY180HE	57.15	35.70	35.70	17.45	75.7	81.3	37.9	43.5	52.5	8.0	68.6		441	70.6
SY180HE-2					144.2	149.8	72.1	77.7				882	121	30.06
SY180HE-3					212.8	218.7	106.4	112.3				1323	179	44.94
SY180HE-4					281.4	287.4	140.7	146.7				1764	236	59.83
SY200HE	63.50	38.10	39.67	19.83	84.9	93.2	42.5	50.8	59.8	9.5	78.3	559	82.3	17.85
SY200HE-2					163.1	172.0	81.6	90.4				1118	138	35.20
SY200HE-3					241.4	250.3	120.7	129.6				1677	204	52.53
SY200HE-4					319.8	328.6	159.9	168.7				2236	269	69.94
SY240HE	76.20	47.63	47.63	23.78	110.2	117.7	55.6	62.0	70.3	12.7	101.2	883	112.8	32.29
SY240HE-2					211.6	218.9	105.8	113.1				1766	192	62.06
SY240HE-3					312.6	320.1	156.3	163.8				2649	283	91.82
SY240HE-4					414.0	421.3	207.0	214.3				3532	373	121.58

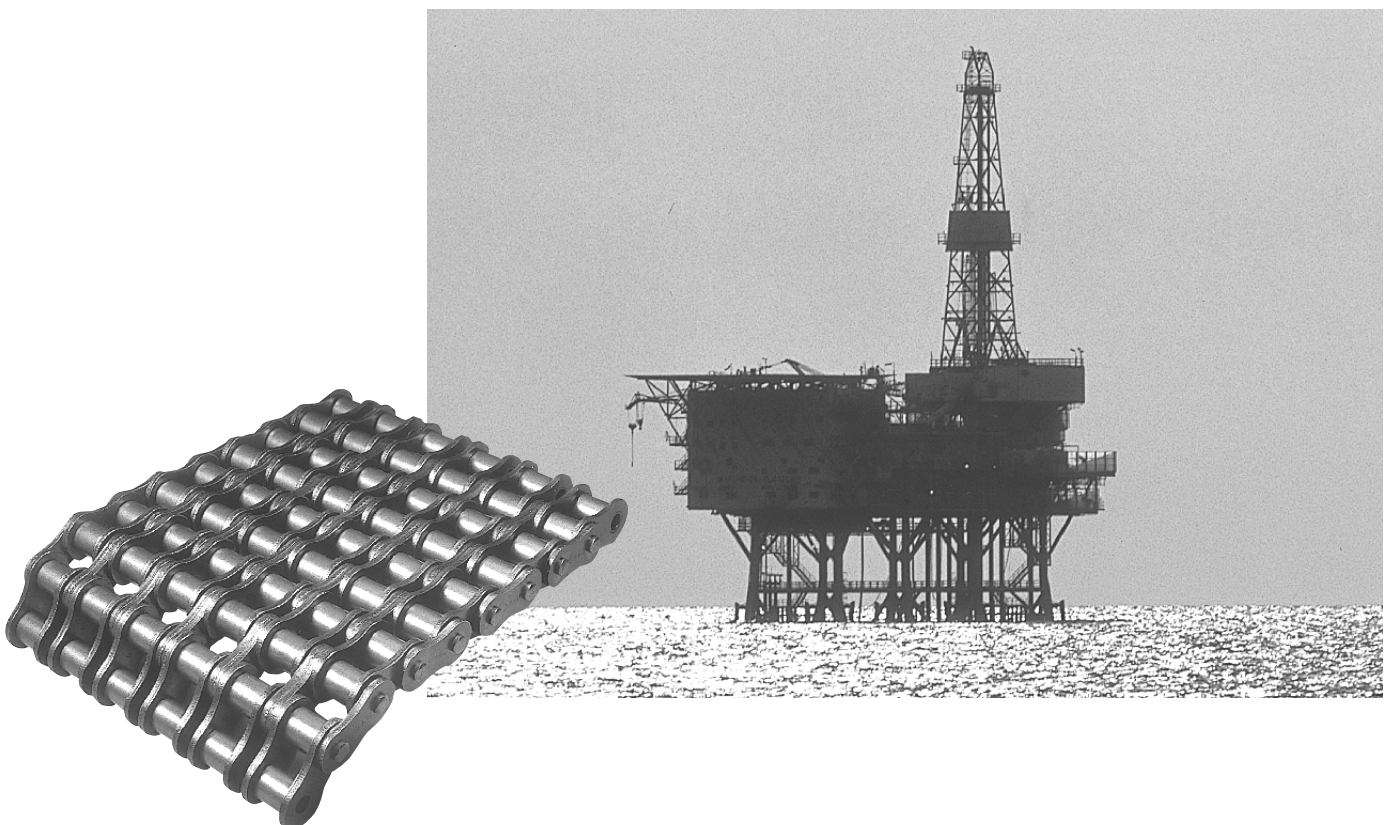

SUPER ROLLER CHAINS

SY Super standard series roller chains are developed to offer you longer service life, thus leading to labor-savings. Thorough consideration to fitting portions and the use of high-grade special alloy steel components ensure the chain's greater resistance of fatigue and shock. Operative on standard roller chain sprockets.

SY super heavy series roller chains provided with link plates of next larger chain size promise you higher performance and superior quality.

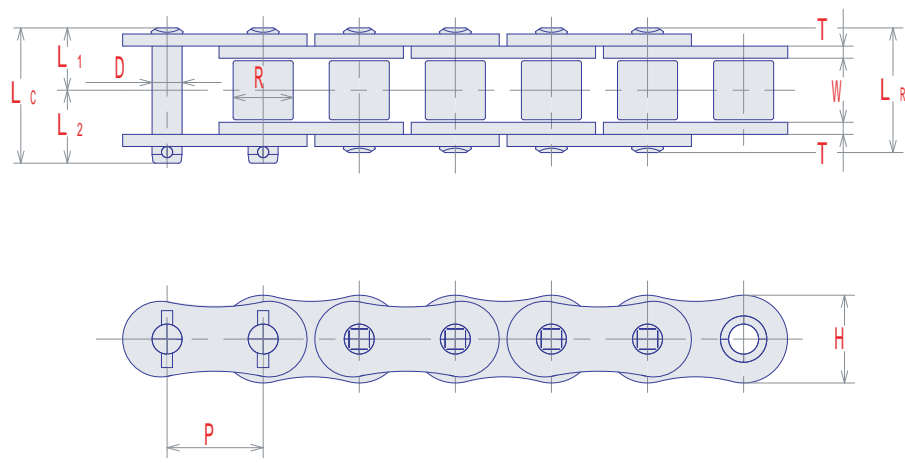

- Note: 1. Offset links are not available.
- 2. Riveted type chain will be provided unless otherwise specified.
- 3. Cotted type chain will be provided upon request.
- 3. Press-fitted type connecting links will be supplied.

SINGLE STRANDS

SY Chain No. (ANSI)	Dimensions - mm										Average Ultimate Strength kN	Maximum Allowable Load kN	Average Chain Weight kg/m
	Pitch P	Roller		Pin				Plate					
		Width W	Dia. R	Dia. D	Length			Height H	Thick. T				
					LR	Lc	L1	L2					
SUPER 80	25.40	15.88	15.88	7.93	32.6	35.5	16.3	19.2	24.1	3.2	84.3	18.6	2.81
SUPER 100	31.75	19.05	19.05	9.53	39.8	43.2	19.9	23.3	30.1	4.0	127	30.4	4.26
SUPER 120	38.10	25.40	22.23	11.10	49.7	53.7	24.9	28.8	36.2	4.8	186	39.2	6.30
SUPER 140	44.45	25.40	25.40	12.70	54.0	58.3	27.0	31.3	42.2	5.6	245	53.9	8.04
SUPER 160	50.80	31.75	28.58	14.28	64.4	69.0	32.2	36.8	48.2	6.4	314	70.6	10.8
SUPER 200	63.50	38.10	39.67	19.83	78.6	86.2	39.3	46.9	60.3	8.0	490	94.1	17.6
SUPER 240	76.20	47.63	47.63	23.78	96.4	103.4	48.2	55.2	72.4	9.5	726	132	25.6
SUPER 80H	25.40	15.88	15.88	7.93	35.9	38.9	18.0	20.9	24.1	4.0	98.1	20.6	3.33
SUPER 100H	31.75	19.05	19.05	9.53	42.6	46.2	21.3	24.9	30.1	4.8	145	32.4	4.88
SUPER 120H	38.10	25.40	22.23	11.10	52.8	57.3	26.4	30.9	36.2	5.6	196	42.2	6.94
SUPER 140H	44.45	25.40	25.40	12.70	57.2	61.9	28.6	33.3	42.2	6.4	255	56.9	8.87
SUPER 160H	50.80	31.75	28.58	14.28	67.9	72.8	34.0	38.8	48.2	7.1	324	73.5	11.7

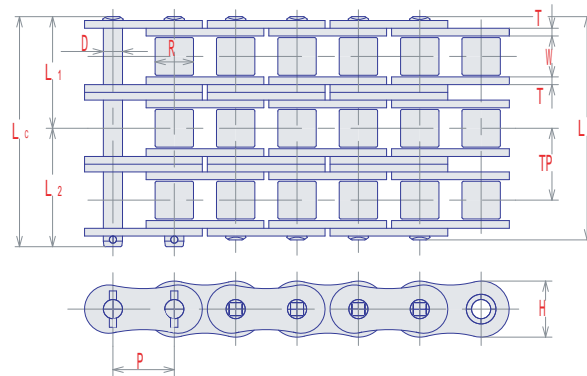

MULTIPLE STRANDS

SY Chain No.	Dimensions - mm											Average Ultimate Strength kN	Maximum Allowable Load kN	Average Chain Weight kg/m
	Pitch P	Roller		Pin				Plate		Trans. Pitch TP				
		Width W	Dia. R	Dia. D	Length			Height H	Thick. T					
					L _R	L _C	L ₁	L ₂						
SUPER80-2	25.40	15.88	15.88	7.93	62.0	64.9	31.0	33.9	24.1	3.2	29.3	169	31.6	5.63
SUPER80-3					91.3	94.2	45.7	48.5				253	46.5	8.41
SUPER80-4					120.6	123.5	60.3	63.2				337	61.4	11.18
SUPER100-2	31.75	19.05	19.05	9.53	75.4	79.0	37.7	41.3	30.1	4.0	35.8	254	51.7	8.38
SUPER100-3					111.2	114.8	55.6	59.2				381	76.0	12.57
SUPER100-4					147.0	150.6	73.5	77.1				508	100	16.77
SUPER120-2	38.10	25.40	22.23	11.10	95.4	99.4	47.7	51.7	36.2	4.8	45.4	372	66.6	12.44
SUPER120-3					140.8	144.8	70.4	74.4				558	98.0	18.65
SUPER120-4					186.2	190.2	93.1	97.1				744	129	24.85
SUPER140-2	44.45	25.40	25.40	12.70	103.3	107.6	51.7	55.9	42.2	5.6	48.9	490	91.6	15.92
SUPER140-3					152.2	156.5	76.1	80.4				735	135	23.84
SUPER140-4					201.1	205.4	100.6	104.8				980	178	30.72
SUPER160-2	50.80	31.75	28.58	14.28	123.2	127.8	61.6	66.2	48.2	6.4	58.5	628	120	21.44
SUPER160-3					181.7	186.3	90.9	95.4				942	177	32.10
SUPER160-4					240.2	244.8	120.1	124.7				1256	233	42.84
SUPER200-2	63.50	38.10	39.67	19.83	150.6	158.2	75.3	82.9	60.3	8.0	71.6	980	160	34.91
SUPER200-3					222.2	229.8	111.1	118.7				1470	235	52.44
SUPER200-4					293.8	301.4	146.9	154.5				1960	311	69.74
SUPER240-2	76.20	47.63	47.63	23.78	184.2	191.2	92.1	99.1	72.4	9.5	87.8	1452	224	50.88
SUPER240-3					272.0	279.0	136.0	143.0				2178	330	76.12
SUPER240-4					359.8	366.8	179.9	186.9				2904	436	101.40
SUPER 80H-2	25.40	15.88	15.88	7.93	68.6	399.4	34.3	365.1	24.1	4.0	32.6	196.2	35.02	6.67
SUPER 80H-3					101.2	432.0	50.6	381.4				294.3	51.5	9.96
SUPER100H-2	31.75	19.05	19.05	9.53	81.6	85.4	40.8	44.6	30.1	4.8	39.1	290	55.08	9.6
SUPER100H-3					120.7	124.5	60.4	64.1				435	81.0	14.4
SUPER120H-2	38.10	25.40	22.23	11.10	102.0	173.4	51.0	122.4	36.2	5.6	48.9	392	71.74	13.71
SUPER120H-3					150.9	222.3	75.5	79.6				588	105.5	20.55
SUPER140H-2	44.45	25.40	25.40	12.70	109.6	274.5	54.8	219.7	42.2	6.4	52.2	510	96.73	17.56
SUPRR140H-3					161.8	326.7	80.9	245.8				765	142.25	26.3
SUPER160H-2	50.80	31.75	28.58	14.28	223.7	388.6	111.9	276.8	48.2	7.1	61.9	648	124.95	23.15
SUPER160H-3					285.6	450.5	142.8	100.7				972	183.75	34.67

Double Capacity Chains

Double Capacity Chain is a single strand chain that offers the same ultimate tensile strength as a double strand chain with a saving of 50%.

Double Capacity Chain consists of twice the amount of side plates as single strand chain.

DC (x2)

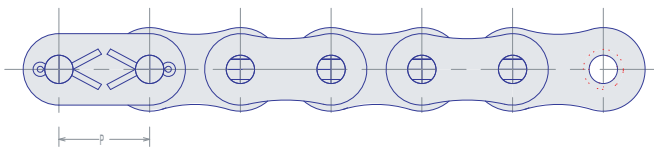
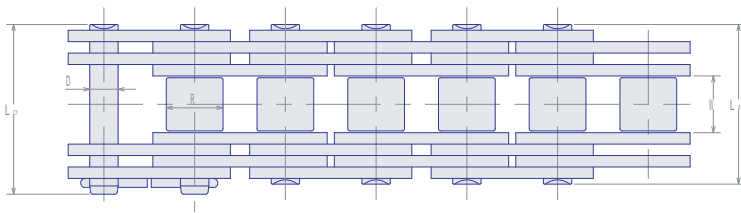

TC (x3)

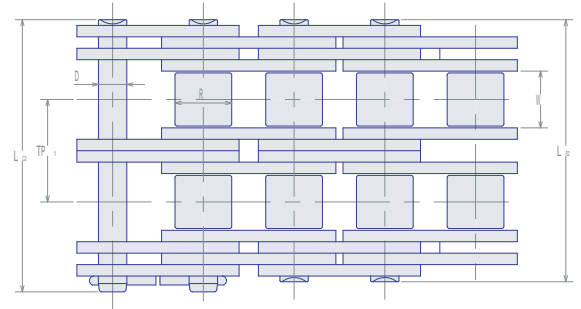

FC (x4)

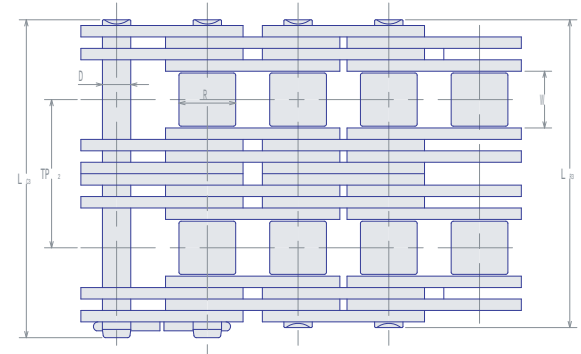

SY Chain No.	Dimensions - mm								Average Ultimate Strength (kN)			Maximum Allowable Load (kN)
	Pitch	Roller		Pin		Transverse Pitch		DC	TC	FC		
		Width	Dia.	Dia.	Length	TP1	TP2					
		P	W	R	D	LR1	LC1					
16BDC • TC • FC	25.40	17.02	15.88	8.26	50.0	53.2	31.9	44.7	137	205	274	19.5
20BDC • TC • FC	31.75	19.56	19.05	10.16	56.0	60.4	36.5	50.5	212	318	424	30.2
24BDC • TC • FC	38.10	25.40	25.40	14.63	75.4	80.5	48.4	68.0	359	538	718	51.2
28BDC • TC • FC	44.45	31.00	27.94	15.88	93.0	98.8	59.6	84.8	447	670	894	63.8
32BDC • TC • FC	50.80	31.00	29.21	17.81	92.4	98.5	58.6	83.8	549	823	1098	78.4
80DC • TC • FC	25.40	15.88	15.88	7.93	45.6	48.7	29.3	42.1	157	235	314	22.4
100DC • TC • FC	31.75	19.05	19.05	9.53	55.8	59.5	35.8	51.8	235	352	470	33.5
120DC • TC • FC	38.10	25.40	22.23	11.10	69.0	73.3	45.4	64.2	343	514	686	49.0
140DC • TC • FC	44.45	25.40	25.40	12.70	76.4	81.1	48.9	71.3	451	676	902	64.4
160DC • TC • FC	50.80	31.75	28.58	14.28	90.0	95.1	58.5	84.1	559	838	1118	79.8
180DC • TC • FC	57.15	35.70	35.70	17.45	101.6	107.7	65.8	94.6	726	1089	1452	103.0
200DC • TC • FC	63.50	38.10	39.67	19.83	111.2	120.0	71.6	103.6	932	1398	1864	133.0
240DC • TC • FC	76.20	47.63	47.63	23.78	135.6	143.2	87.8	125.8	1353	2029	2706	193.0

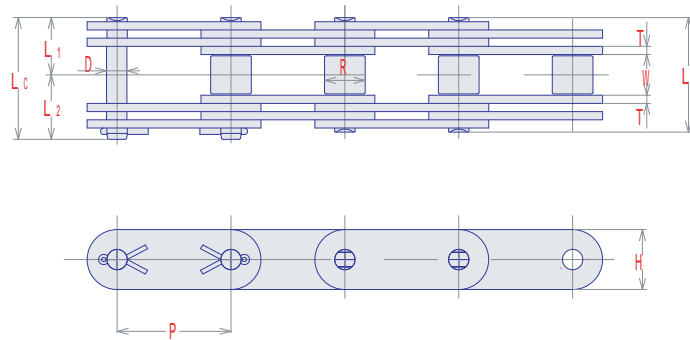

DOUBLE PITCH TYPE

SY Chain No.	Dimensions - mm										Average Ultimate Strength	Maximum Allowable Load	Average Chain Weight
	Pitch	Roller		Pin				Plate					
		Width	Dia.	Dia.	Length			Height	Thick.				
	P	W	R	D	LR	LC	L1	L2	H	T			
2040 DC	25.40	7.95	7.92	3.96	23.0	24.7	11.5	13.2	11.4	1.5	38.2	4.02	0.50
2050 DC	31.75	9.53	10.16	5.08	28.8	30.5	14.4	16.1	15.0	2.0	63.8	6.72	0.85
2060H DC	38.10	12.70	11.91	5.95	42.2	44.2	21.1	23.1	17.0	3.2	109.8	11.56	1.46
2080H DC	50.80	15.88	15.88	7.93	52.0	55.1	26.0	29.1	22.6	4.0	180.4	18.99	2.50
2100H DC	63.50	19.05	19.05	9.53	62.0	65.6	31.0	34.6	28.6	4.8	274.0	28.84	3.81
2120H DC	76.20	25.40	22.23	11.10	77.8	82.1	38.9	43.2	34.9	5.6	372.0	39.16	5.50
2160H DC	101.60	31.75	28.58	14.28	97.4	102.6	48.7	53.9	47.6	7.2	612.0	64.42	9.27

S-SERIES ROLLER CHAINS

S-series roller chains are designed for high breaking strength and maximum endurance in pursuit of greater chain rigidity. Combination of plates one size thicker than standard's and thick, tough pins ensures accurate operations and long performance life under harsh, heavy loads. Single strand roller chains of this series run on standard single roller chain sprockets.

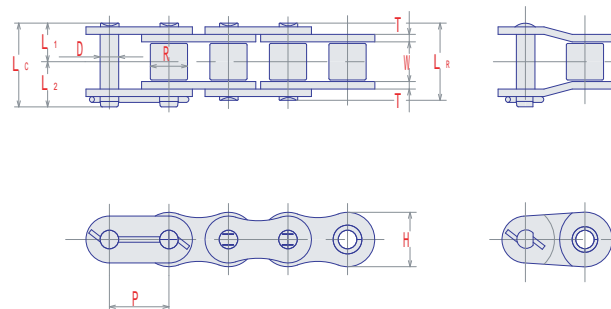

SY Chain No.	Dimensions - mm										Average Ultimate Strength	Maximum Allowable Load	Average Chain Weight
	Pitch	Roller		Pin				Plate					
		Width	Dia.	Dia.	Length			Height	Thick.				
	P	W	R	D	LR	LC	L1	L2	H	T			
SY 251S	50.80	31.75	28.58	15.88	67.9	73.2	34.0	39.2	46.7	7.2	333	58.8	11.31
SY 264S	63.50	38.10	39.67	22.22	85.8	94.5	42.9	51.6	59.8	9.5	556	81.4	19.27

DOUBLE PITCH ROLLER CHAINS (DRIVE SERIES)

DOUBLE PITCH
ROLLER CHAINS

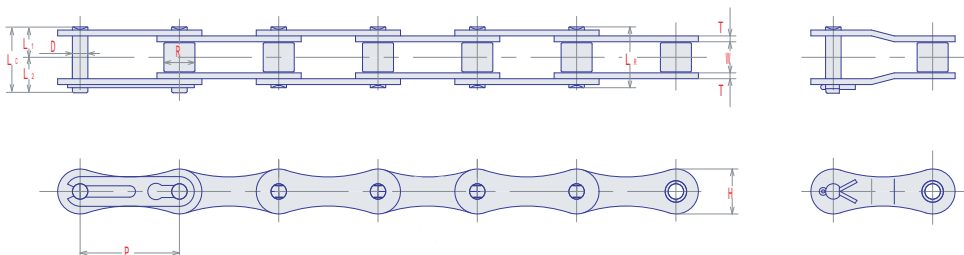

DRIVE SERIES

SY Chain No. (ANSI)	Dimensions - mm										Average Ultimate Strength	Maximum Allowable Load	Average Chain Weight
	Pitch	Roller		Pin				Plate					
		Width	Dia.	Dia.	Length			Height	Thick.				
		P	W	R	D	LR	LC	L1	L2	H			
A2040	25.40	7.95	7.92	3.96	16.5	17.9	8.3	9.6	11.4	1.5	16.7	2.65	0.43
A2050	31.75	9.53	10.16	5.08	20.4	22.0	10.2	11.8	15.0	2.0	27.5	4.31	0.73
A2060	38.10	12.70	11.91	5.95	25.5	26.9	12.8	14.1	17.0	2.4	40.2	6.23	1.03
A2080	50.80	15.88	15.88	7.93	32.8	35.2	16.4	18.8	22.6	3.2	68.2	10.7	1.71



DOUBLE PITCH ROLLER CHAINS (CONVEYOR SERIES)

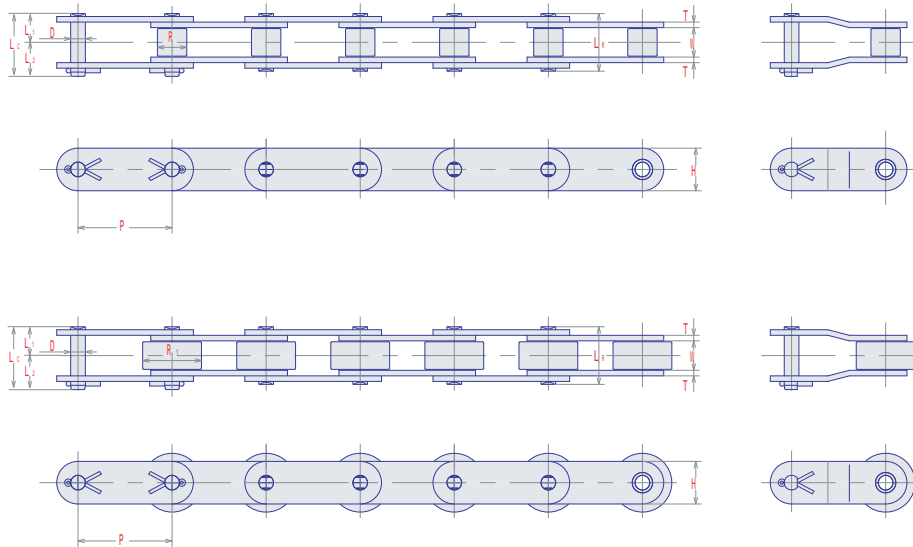

DOUBLE PITCH
ROLLER CHAINS

STANDARD ROLLER TYPE

SY Chain No. (ANSI)	Dimensions - mm										Average Ultimate Strength	Maximum Allowable Load	Average Chain Weight
	Pitch	Roller		Pin				Plate					
		Width	Dia.	Dia.	Length			Height	Thick.				
		P	W	R	D	LR	LC	L1	L2	H			
C2040	25.40	7.95	7.92	3.96	16.5	18.5	8.2	10.3	11.4	1.5	16.9	3.63	0.48
C2050	31.75	9.53	10.16	5.08	20.4	22.0	10.2	11.8	15.0	2.0	27.5	6.28	0.82
C2060H	38.10	12.70	11.91	5.95	28.7	31.0	14.4	16.6	17.0	3.2	40.2	8.63	1.38
C2080H	50.80	15.88	15.88	7.93	35.5	38.8	17.8	21.0	22.6	4.0	68.6	14.7	2.32
C2100H	63.50	19.05	19.05	9.53	42.2	45.7	21.1	24.6	28.6	4.8	107.9	22.6	3.46
C2120H	76.20	25.40	22.23	11.10	52.6	57.0	26.3	30.7	34.9	5.6	151.0	30.4	4.92
C2160H	101.60	31.75	28.58	14.28	67.7	72.9	33.9	39.0	47.6	7.2	257.9	53.0	8.02

CARRIER ROLLER TYPE

SY Chain No. (ANSI)	Dimensions - mm										Average Ultimate Strength	Maximum Allowable Load	Average Chain Weight
	Pitch	Roller		Pin				Plate					
		Width	Dia.	Dia.	Length			Height	Thick.				
		P	W	R	D	LR	LC	L1	L2	H			
C2042	25.40	7.95	15.88	3.96	16.5	18.5	8.2	10.3	11.4	1.5	16.9	3.63	0.82
C2052	31.75	9.53	19.05	5.08	20.4	22.0	10.2	11.8	15.0	2.0	27.5	6.28	1.26
C2062H	38.10	12.70	22.23	5.95	28.7	31.0	14.4	16.6	17.0	3.2	40.2	8.63	2.08
C2082H	50.80	15.88	28.58	7.93	35.5	38.8	17.8	21.0	22.6	4.0	68.6	14.7	3.36
C2102H	63.50	19.05	39.67	9.53	42.2	45.7	21.1	24.6	28.6	4.8	107.9	22.6	5.64
C2122H	76.20	25.40	44.45	11.10	52.6	57.0	26.3	30.7	34.9	5.6	151.0	30.4	7.87
C2162H	101.60	31.75	57.15	14.28	67.7	72.9	33.9	39.0	47.6	7.2	257.9	53.0	12.77

Stainless Steel Chains

SS series stainless steel roller chains provide excellent corrosion protection against low or high temperature, acid, alkali, moisture, scale, oil and magnetism.

SS series stainless steel roller chains are manufactured in accordance with the dimensions ANSI standards.

INTRODUCTION OF SY NEW HIGH POWER NEW SSS SERIES PRODUCTS

SSS series stainless steel roller chains with solid rollers.

Anti-magnetic of solid roller has superior permeability than the common curled roller.

High Power New SSS Chain use a specially treated pin and roller.

Extremely long life is engaged by this surface treatment.

SSS series chain life is more than 2 times longer than that of normal SS series Chain.

50% Higher Allowable Loads

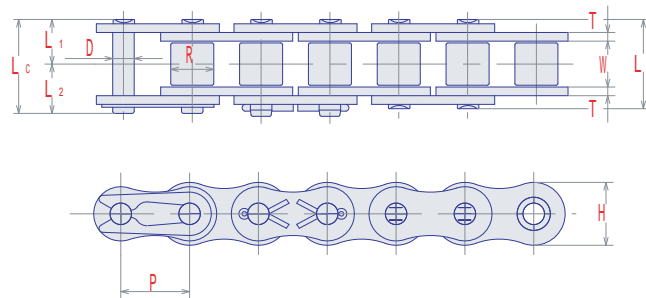

BS AND ANSI STAINLESS STEEL CHAIN

SY Chain No.	Dimensions - mm										Minimum Ultimate Strength	Maximum Allowable Load	Average Chain Weight
	Pitch	Roller		Pin				Plate					
		Width	Dia.	Dia.	Length			Height	Thick.				
		P	W	R	D	LR	Lc	L1	L2	H			
06B-SS	9.525	5.72	6.35	3.28	12.6	13.4	6.3	7.1	8.2	1.0/1.25	6.18	0.27	0.43
08B-SS	12.70	7.75	8.51	4.45	16.7	17.8	8.4	9.4	11.8	1.5	10.3	0.52	0.61
10B-SS	15.875	9.65	10.16	5.08	19.0	20.6	9.5	11.1	14.7	1.65	15.7	0.68	0.89
12B-SS	19.05	11.68	12.07	5.72	22.0	23.6	11.0	12.6	16.1	1.8	18.1	0.88	1.14
16B-SS	25.40	17.02	15.88	8.26	35.1	38.2	17.6	20.6	20.3	3.2/4.0	42.2	2.06	2.59
	P	W	R	D	LR	Lc	L1	L2	H	T1/T2	kN	kN	kg/m
SY 35-SS	9.525	4.78	5.08	3.58	12.2	13.7	6.1	7.6	9.0	1.25	5.68	0.26	0.34
SY 40-SS	12.70	7.95	7.92	3.96	16.9	18.5	8.5	10.0	11.7	1.5	11.1	0.44	0.60
SY 50-SS	15.875	9.53	10.16	5.08	20.8	22.3	10.4	11.9	14.6	2.0	17.6	0.68	0.98
SY 60-SS	19.05	12.70	11.91	5.95	26.0	27.9	13.0	14.9	17.5	2.4	24.5	1.03	1.46
SY 80-SS	25.40	15.88	15.88	7.93	32.8	35.5	16.4	19.1	23.4	3.2	42.3	1.77	2.52
SY 100-SS	31.75	19.05	19.05	9.53	40.0	43.3	20.0	23.3	29.3	4.0	51.0	2.55	3.91
SY 120-SS	38.10	25.40	22.23	11.10	50.4	54.2	25.2	29.0	35.1	4.8	68.6	3.92	5.76
SY 140-SS	44.45	25.40	25.40	12.70	54.0	58.3	27.0	31.3	40.9	5.6	88.2	4.66	7.41
SY 160-SS	50.80	31.75	28.58	14.28	64.3	68.7	32.2	36.5	46.7	6.4	109.8	6.37	9.79

Chain is rollerless R shows bushing dia.
304 Stainless steel.

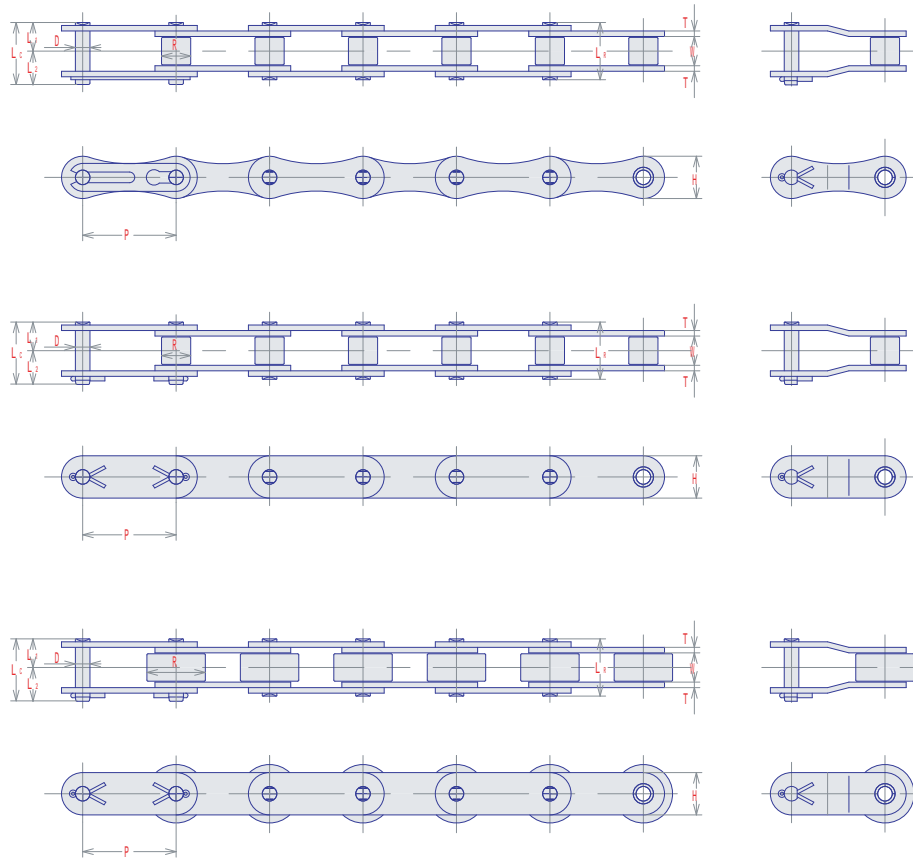

DOUBLE PITCH STAINLESS STEEL CHAIN

SY Chain No.	Dimensions - mm										Average Ultimate Strength	Maximum Allowable Load	Average Chain Weight
	Pitch	Roller		Pin				Plate					
		Width	Dia.	Dia.	Length				Height	Thick.			
P	W	R	D	LR	LC	L1	L2	H	T	kN	kN	kg/m	
A2040-SS	25.40	7.95	7.92	3.96	16.9	18.5	8.5	10.0	11.4	1.5	12.4	0.44	0.43
A2050-SS	31.75	9.53	10.16	5.08	20.8	22.3	10.4	11.9	15.0	2.0	20.3	0.68	0.73
A2060-SS	38.10	12.70	11.91	5.95	26.0	27.9	13.0	14.9	17.0	2.4	27.4	1.03	1.03
A2080-SS	50.80	15.88	15.88	7.93	32.8	35.5	16.4	19.1	22.6	3.2	47.1	1.77	1.71
C2040-SS	25.40	7.95	7.92	3.96	16.9	18.5	8.5	10.0	11.4	1.5	12.4	0.44	0.48
C2050-SS	31.75	9.53	10.16	5.08	20.8	22.3	10.4	11.9	15.0	2.0	20.3	0.68	0.82
C2060H-SS	38.10	12.70	11.91	5.95	28.8	30.9	14.4	16.5	17.0	3.2	27.4	1.03	1.38
C2080H-SS	50.80	15.88	15.88	7.93	35.7	38.8	17.9	20.9	22.6	4.0	47.1	1.77	2.32
C2100H-SS	63.50	19.05	19.05	9.53	42.4	46.0	21.2	24.8	28.6	4.8	56.9	2.55	3.46
C2120H-SS	76.20	25.40	22.23	11.10	52.8	57.2	26.4	30.8	34.9	5.6	76.5	3.92	4.92
C2160H-SS	101.60	31.75	28.58	14.28	67.9	73.1	34.0	39.1	47.6	7.2	123	6.37	8.02
C2042-SS	25.40	7.95	15.88	3.96	16.9	18.5	8.5	10.0	11.4	1.5	12.4	0.44	0.82
C2052-SS	31.75	9.53	19.05	5.08	20.8	22.3	10.4	11.9	15.0	2.0	20.3	0.68	1.26
C2062H-SS	38.10	12.70	22.23	5.95	28.8	30.9	14.4	16.5	17.0	3.2	27.4	1.03	2.08
C2082H-SS	50.80	15.88	28.58	7.93	35.7	38.8	17.9	20.9	22.6	4.0	47.1	1.77	3.36
C2102H-SS	63.50	19.05	39.67	9.53	42.4	46.0	21.2	24.8	28.6	4.8	56.9	2.55	5.64
C2122H-SS	76.20	25.40	44.45	11.10	52.8	57.2	26.4	30.8	34.9	5.6	76.5	3.92	7.87
C2162H-SS	101.60	31.75	57.15	14.28	67.9	73.1	34.0	39.1	47.6	7.2	123	6.37	12.77

304 Stainless steel

Selection of Stainless Steel Chain

Chain selection should be made based on the bearing pressure as shown below

$$\text{Max. Allowable Load : } \frac{\text{PIN DIA.}^{\text{mm}} \times \text{BUSHING LENGTH}^{\text{mm}} \times \text{P}^{\text{Mpa}}}{1000} = \text{kN}$$

$$\text{Max. Allowable Load } f1 \times f2 \times f3 \times f4 \times f5 \times [\text{Calculated Chain Tension}]$$

NEW Chain

		SS SERIES		SSS SERIES	600 SERIES
Material	Plate	SUS304	SUS316	SUS304	SUS304
	Pin	SUS304	SUS316	SUS304	600
	Bushing	SUS304	SUS316	SUS304	SUS304
	Roller	SUS304	SUS316	SUS304	600
Shap of roller		Solid	Solid	Solid	Solid
Bearing Pressure (P)		9.8	9.8	14.7	14.7
Non-Magnetize					
Corrosion Resistance					
Heat Resistance					
Wear Resistance					
Stress Corrosin					
Cracking Resistance		x		x	x
Chain Number	#35 - #120	#35 - #120	#35 - #160	#40 - #100	
	- C2100H	- C2080H	- C2100H	- C2100H	

Rating :
 Excellent
 Good
 Fair
 x Not Recommended

Service Factor (f1)

Condition	(f1)
Smooth	1.0
Some Impact	1.2
Large Impact	1.5

Service Factor (f2)

Chain Speed (m/s)	(f2)
0 - 15	1.0
15 - 30	1.2
30 - 50	1.4
50 - 70	1.6

Service Factor (f3)

Temperature (°C)	304SS	316SS	600
- 40 to - 20	1.0	1.0	x
- 20 - 400	1.0	1.0	1.0
400 - 500	1.2	1.2	1.8
500 - 600	1.5	1.5	x
600 - 700	1.8	1.8	x
700 - 800	x	2.0	x

x : Not Recommended

Service Factor (f4)

See next page

Corrosion Rating	(f4)
1	1.00
2	1.23
3	1.44
4	x

x : Not Recommended

Service Factor (f5)

Lubrication	(f5)
Lubricate	1.00
dry	1.44

STAINLESS CHAIN CORROSION RESISTANCE GUIDE

CORROSION RATING

Agent		Stainless Steel			Agent		Stainless Steel		
		304	600	316			304	600	316
Acidic acid	20 ºC	1	1	1	Linseed Oil	1	1	1	
	Boiling	2	2	1	Lye	20 ºC	1	1	1
Acidic Vapors		3	4	2		Boiling	2	3	1
Acetone		1	1	1	Magnesium Chloride	20 ºC	2	3	1
Alcohol		1	1	1		Hot	3	4	2
Aluminum Chloride		3	4	2	Malic acid		1	1	1
Aluminum Sulfate	20 ºC	1	1	1	Marsh gas		1	1	1
	Boiling	2	3	1	Mayonnaise		2	3	1
Ammonia		1	1	1	Mercury		1	1	1
Ammonium Chloride	20 ºC	1	1	1	Milk		1	1	1
	Boiling	2	3	1	Mine water (acid)		1	1	1
Ammonium Nitrate		1	1	1	Molasses		1	1	1
Baking Soda		1	1	1	Nickel Chloride		2	3	1
Barium Carbonate		1	1	1	Nickel Sulfate		1	1	1
Barium Chloride	20 ºC	1	1	1	Nitric Acid	20 ºC	1	1	1
	Hot	2	3	1	Concentrated	Boiling	3	4	2
Beer		1	1	1		Fuming	3	4	2
Beet Juice		1	1	1	Oleic Acid		2	3	1
Benzine		1	1	1	Oils	Mineral	1	1	1
Bleaching Powder		2	4	1		Vegetable	1	1	1
Blood(meat juices)		1	1	1		Refined	1	1	1
Boric Acid		1	1	1		Crude	2	3	1
Calcium Chloride(Alkaline)		2	2	1	Oxalic Acid		1	1	1
Calcium Chloride		3	4	2	Paraffin		1	1	1
Calcium Sulfate		1	1	1	Phenol (Carbolic acid)		1	1	1
Carbolic Acid		1	1	1	Phosphoric Acid	boiling	4	4	3
Carbon Tetrachloride		1	2	1	Potash		1	1	1
Caustic Lime, Potassium		1	1	1	Potassium Chloride		2	3	1
Chlorine gas	Dry	3	4	2	Potassium Cyanide		1	1	1
	Moist	4	4	3	Potassium Nitrate		1	1	1
Chlorinated water		2	3	1	Potassium Sulfate		1	1	1
Chromic Acid	20 ºC	1	1	1	Potassium Sulfide		1	1	1
	Boiling	3	4	1	Salt	20 ºC	1	2	1
Citric Acid	20 ºC	1	1	1		65 ºC	2	3	1
	Boiling	3	4	1	Sea Water		2	3	1
Ferric Chloride		3	4	2	Sewage(sulfuric acid)		2	3	1
Formic Acid		2	3	1	Sodium Acetate		1	1	1
Fruit juices		1	2	1	Sodium Chloride	20 ºC	1	1	1
Fuel Oil		1	1	1		Boiling	2	3	1
Fuel oil with sulfuric		3	4	3	Sodium Cyanide		1	1	1
Gasoline		1	1	1	Sodium Fluoride		2	3	1
Glue		1	1	1	Sodium Hydroxide		1	1	1
Glue acidified		2	3	1	Sodium Peroxide		1	1	1
Glycerin		1	1	1	Sodium Sulfate		1	1	1
Grape juices		1	1	1	Sodium Sulfide		2	3	1
Gypsum(Calcium Sulfate)		1	1	1	Sodium Sulfite		1	1	1
Hydrochloric acid	2%	4	4	4	Soap		1	1	1
Hydrogen Peroxide	30%	1	2	1	Sulfuric Acid	20 ºC	2	3	1
Hydrogen Sulfide	Dry	1	1	1		Boiling	4	4	2
	Moist	4	4	4		Fuming	3	4	1
Iodine	Dry	1	1	1		Vapor	2	3	1
	Moist	4	4	3	Vinegar(Acetic Acid)		1	1	1
Ketchup		1	1	1	Whiskey		1	1	1
Lactic acid	20 ºC	1	1	1	Wood Pulp		1	1	1
	65 ºC	3	4	1	Zinc Chloride	20 ºC	1	1	1
Lard		1	1	1		Boiling	3	4	2

AQUA-PROOF ROLLER CHAINS

Feature

Excellent corrosion resistance without plating same strength and working load values as standard chain No hydrogen embrittlement by surface treatment.

Results of corrosion resistant tests

Salt spray test

CHAINS	Hour for Rust developed(hours)
Special surface treated	1000 No rust
Glossy chromating	72 ~ 96
Colored chromating	120 ~ 240
Molten zinc plating	120 ~ 240

Salt spray test

CHAINS	Hour for Rust developed(hours)
Nickel plated	48
Special surface treated	600 ~ 840
Made of SUS304 stainless steel	above 840 No rust

Applications

Outdoor service
Sea water applications
Stacking crane, Car parking

Applicable Chains

#40 ~ #240
Attachment chain is available.

Purpose of Special surface treatment

Linkplate : for anticorrosion
Other parts : for anticorrosion and to reduce friction

Caution

For the food products industry where the chain may be exposed to direct food contact, stainless steel chain is recommended.

Applicable Chains

SY40AP~SY240AP
Attachment chain is available.
For identification, a suffix is added to the chain numbers.

THE ULTIMATE ROLLER CHAIN **LONG LIFE SERIES**

SBR

**AQUA-PROOF
ROLLER CHAIN**

BS STANDARD ROLLER CHAINS
ANSI STANDARD ROLLER CHAINS
HEAVY-SERIES ROLLER CHAINS
S-SERIES ROLLER CHAINS
SUPER ROLLER CHAINS
OIL-FIELD CHAINS
ROLLERLESS CHAINS
STRAIGHT SIDEBAR CHAINS
DOUBLE PITCH ROLLER CHAINS etc.

ANTICORROSIIVE TEST

STANDARD

NP

STAINLESS STEEL

AP

Open air,
splashed water
morning&evening



3days after

RUSTLESS CHAINS

STANDARD

NP

STAINLESS STEEL

AP

Open air,
splashed water
morning&evening



15days after

STANDARD

NP

STAINLESS STEEL

AP

Indoors,
splashed
5% salty water
morning&evening



15days after

Nickel-Plated BS Chains

Ideal for outdoor operations and in situations where machinery and equipment must be run in a lightly corrosive atmosphere or where good chain appearance may be desired. For identification, a suffix NP is added to the chain numbers.

RUSTLESS CHAINS

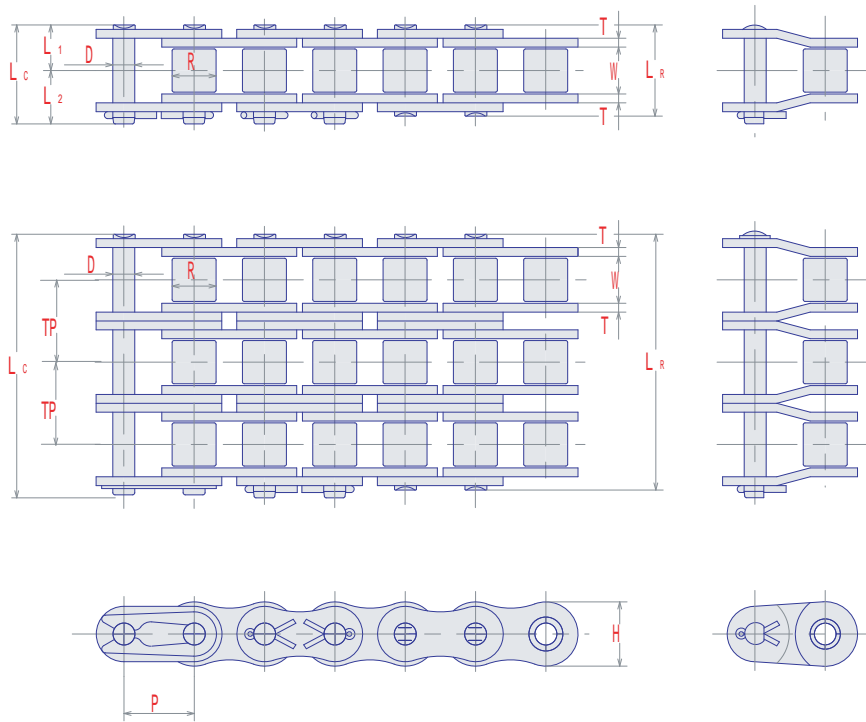

NP BS STANDARD

SY Chain No.	Dimensions - mm												Minimum Ultimate Strength kN	Maximum Allowable Load kN	Average Chain Weight kg/m
	Pitch P	Roller		Pin				Plate		Trans. Pitch TP					
		Width W	Dia. R	Dia. D	Length			Height H	Thickness						
					LR	LC	L1	L2		T1	T2				
06B-NP	9.525	5.72	6.35	3.28	12.6	13.4	6.3	7.1	8.2	1.0	1.25	10.24	8.92	1.77	0.43
08B-NP	12.70	7.75	8.51	4.45	16.7	18.0	8.4	9.6	11.8	1.5	1.5	13.92	17.8	3.14	0.61
10B-NP	15.875	9.65	10.16	5.08	19.0	20.7	9.5	11.2	14.7	1.65	1.65	16.59	22.2	4.90	0.89
12B-NP	19.05	11.68	12.07	5.72	22.0	23.6	11.0	12.6	16.1	1.8	1.8	19.46	28.9	7.06	1.14
16B-NP	25.40	17.02	15.88	8.26	35.1	38.2	17.6	20.5	20.6	3.2	4.0	31.88	60	12.6	2.59
20B-NP	31.75	19.56	19.05	10.16	40.2	44.0	20.1	23.9	26.4	3.5	4.5	36.45	95	19.6	3.76
06B-NP-2	9.525	5.72	6.35	3.28	22.9	23.7	11.5	12.2	8.2	1.0	1.25	10.24	16.9	3.00	0.81
08B-NP-2	12.70	7.75	8.51	4.45	30.6	31.9	15.3	16.6	11.8	1.5	1.5	13.92	31.1	5.35	1.26
10B-NP-2	15.875	9.65	10.16	5.08	35.6	37.3	17.8	19.5	14.7	1.65	1.65	16.59	44.5	8.33	1.79
12B-NP-2	19.05	11.68	12.07	5.72	41.6	43.1	20.8	22.3	16.1	1.8	1.8	19.46	57.8	12.0	2.28
16B-NP-2	25.40	17.02	15.88	8.26	67.2	70.1	33.6	36.5	20.6	3.2	4.0	31.88	106	21.4	5.13
20B-NP-2	31.75	19.56	19.05	10.16	76.8	80.6	38.4	42.2	26.4	3.5	4.5	36.45	170	33.3	7.26

Refer to page 80. " Selection of offset link "

Nickel-Plated ANSI Chains

Ideal for outdoor operations and in situations where machinery and equipment must be run in a lightly corrosive atmosphere or where good chain appearance may be desired. For identification, a suffix NP is added to the chain numbers.

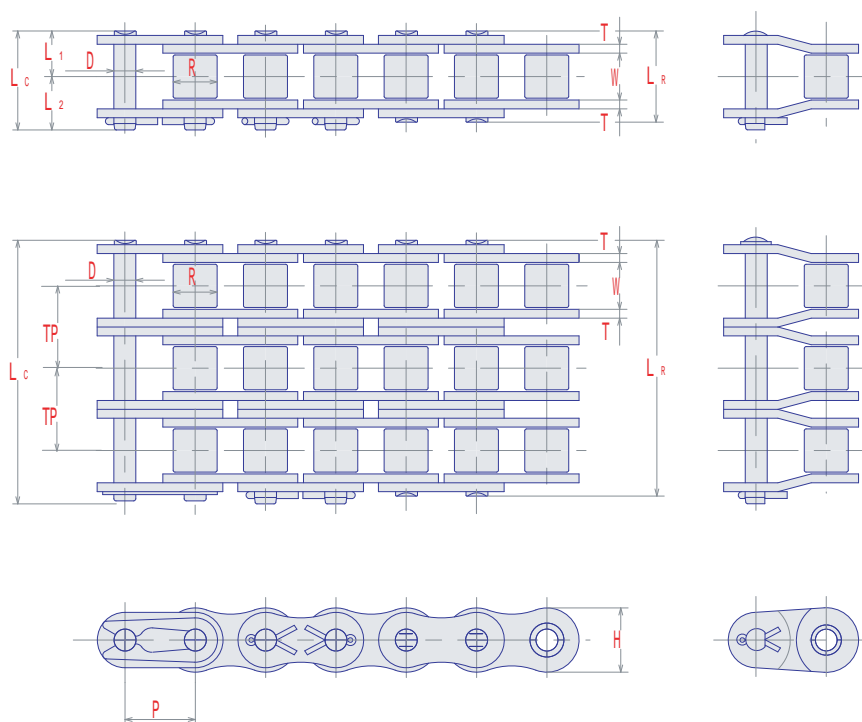

RUSTLESS CHAINS

NP ANSI STANDARD

SY Chain No.	Dimensions - mm											Average Ultimate Strength kN	Maximum Allowable Load kN	Average Chain Weight kg/m
	Pitch P	Roller		Pin				Plate		Trans. Pitch TP				
		Width W	Dia. R	Dia. D	Length			Height H	Thick. T					
					LR	LC	L1	L2						
SY 35NP	9.525	4.78	*5.08	3.58	12.0	12.9	6.0	6.9	9.0	1.25		10.8	1.86	0.34
SY 40NP	12.70	7.95	7.92	3.96	16.5	17.7	8.3	9.4	11.7	1.5		19.1	3.04	0.60
SY 50NP	15.875	9.53	10.16	5.08	20.4	21.9	10.2	11.7	14.6	2.0		31.9	5.39	0.98
SY 60NP	19.05	12.70	11.91	5.95	25.5	26.9	12.8	14.1	17.5	2.4		43.1	7.26	1.46
SY 80NP	25.40	15.88	15.88	7.93	32.8	35.5	16.4	19.1	23.4	3.2		78.5	12.7	2.52
SY100NP	31.75	19.05	19.05	9.53	39.4	43.0	19.7	23.3	29.3	4.0		118	19.1	3.91
SY 35NP-2	9.525	4.78	*5.08	3.58	22.1	23.0	11.1	11.9	9.0	1.25	10.1	21.6	3.16	1.63
SY 40NP-2	12.70	7.95	7.92	3.96	30.8	32.2	15.4	16.8	11.7	1.5	14.4	38.2	5.17	1.22
SY 50NP-2	15.875	9.53	10.16	5.08	38.4	40.0	19.2	20.8	14.6	2.0	18.1	63.8	9.06	2.00
SY 60NP-2	19.05	12.70	11.91	5.95	48.2	49.7	24.0	25.7	17.5	2.4	22.8	86.2	12.3	2.95
SY 80NP-2	25.40	15.88	15.88	7.93	61.6	64.5	30.8	33.7	23.4	3.2	29.3	157	21.6	5.10
SY100NP-2	31.75	19.05	19.05	9.53	75.1	78.8	37.6	41.2	29.3	4.0	35.8	236	32.5	7.74

*Chain is rollerless ;R shows bushing dia.
Refer to page 80. " Selection of offset link "

Nickel-Plated Double Pitch Chains

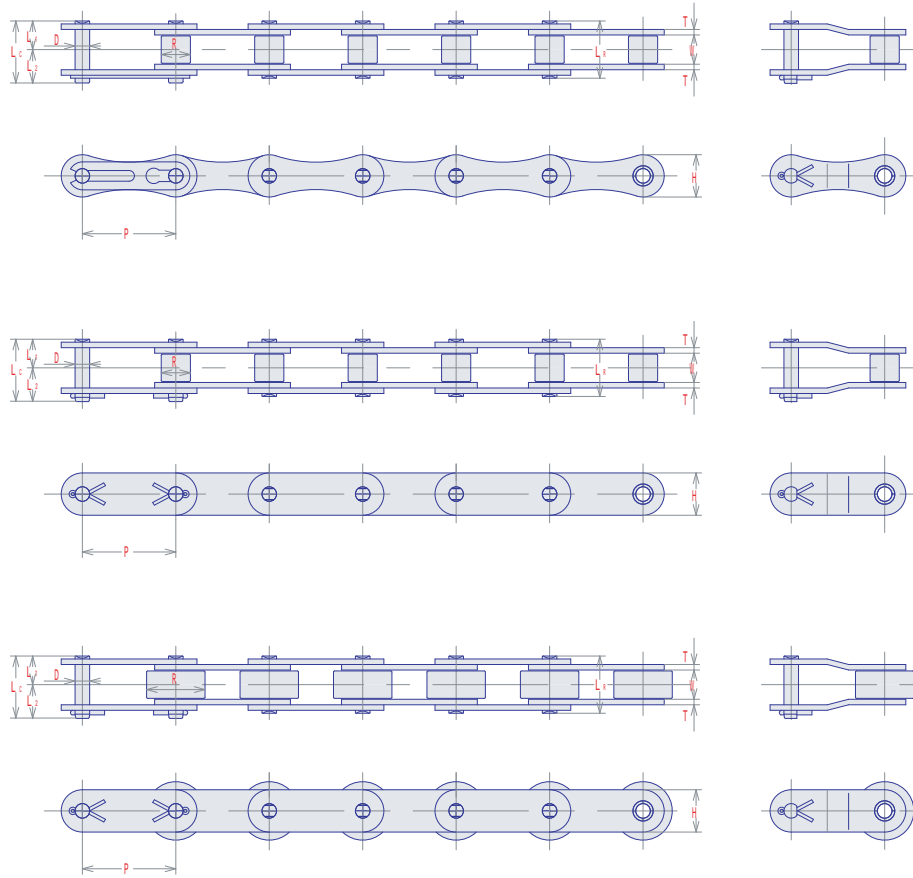

NP DOUBLE PITCH

SY Chain No.	Dimensions - mm										Average Ultimate Strength	Maximum Allowable Load	Average Chain Weight
	Pitch	Roller		Pin				Plate					
		Width	Dia.	Dia.	Length			Height	Thick.				
		P	W	R	D	LR	LC	L1	L2	H			
A2040-NP	25.40	7.95	7.92	3.96	16.4	18.5	8.2	10.3	11.4	1.5	16.9	2.65	0.43
A2050-NP	31.75	9.53	10.16	5.08	20.3	22.0	10.2	11.8	15.0	2.0	27.5	4.31	0.73
A2060-NP	38.10	12.70	11.91	5.95	25.4	27.5	12.7	14.8	17.0	2.4	40.2	6.23	1.03
A2080-NP	50.80	15.88	15.88	7.93	32.4	35.5	16.4	19.1	22.6	3.2	68.6	10.7	1.71
C2040-NP	25.40	7.95	7.92	3.96	16.4	18.5	8.2	10.3	11.4	1.5	16.9	2.65	0.48
C2050-NP	31.75	9.53	10.16	5.08	20.3	22.0	10.2	11.8	15.0	2.0	27.5	4.31	0.82
C2060H-NP	38.10	12.70	11.91	5.95	28.7	31.0	14.4	16.6	17.0	3.2	40.2	8.29	1.38
C2080H-NP	50.80	15.88	15.88	7.93	35.5	38.8	17.8	21.0	22.6	4.0	68.6	15.2	2.32
C2100H-NP	63.50	19.05	19.05	9.53	42.2	45.7	21.1	24.6	28.6	4.8	107.9	23.0	3.46
C2042-NP	25.40	7.95	15.88	3.96	16.4	18.5	8.2	10.3	11.4	1.5	16.9	2.65	0.82
C2052-NP	31.75	9.53	19.05	5.08	20.3	22.0	10.2	11.8	15.9	2.0	27.5	4.31	1.26
C2062H-NP	38.10	12.70	22.23	5.95	28.7	31.0	14.4	16.6	17.0	3.2	40.2	8.29	2.08
C2082H-NP	50.80	15.88	28.58	7.93	35.5	38.8	17.8	21.0	22.6	4.0	68.6	15.2	3.36
C2102H-NP	63.50	19.05	39.67	9.53	42.2	45.7	21.1	24.6	28.6	4.8	107.9	23.0	5.64

Side Bow Chains

SY Side Bow chains provide extra clearance between pins, bushings, and link plates to allow freedom of operation around a curve or twist. The basic dimensions and quality are the same as those of ANSI standard roller chains. Side bow chain is widely used for live roll conveyors, and with attachments to convey material around curves. For identification, the suffix SB is added the number.

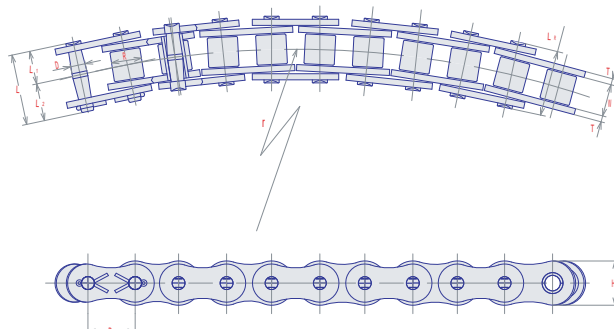

SB STANDARD

SY Chain No.	Dimensions - mm											Average Ultimate Strength kN	Maximum Allowable Load kN	Average Chain Weight kg/m
	Pitch P	Roller		Pin				Plate		Min. Curve Radius r				
		Width W	Dia. R	Out Dia. D	Length		Height H	Thick. T						
SY 40-SB	12.70	7.95	7.92	3.96	16.9	18.9	8.5	10.4	11.7	1.5	350	14.9	1.77	0.63
SY 50-SB	15.875	9.53	10.16	5.08	21.1	23.1	10.6	12.5	14.6	2.0	400	22.1	3.14	1.03
SY 60-SB	19.05	12.70	11.91	5.95	26.3	28.1	13.2	14.9	17.5	2.4	500	29.4	4.22	1.46
SY 80-SB	25.40	15.88	15.88	7.93	33.4	36.4	16.7	19.7	23.4	3.2	600	57.9	7.65	2.42

Stainless steel, nickel plated, and with attachments are supplied on request.

Side Bow Double Pitch Chains

SY Double pitch side bow chains are manufactured to the same high standards as our regular side bow chains but are better suited when shaft centers are relatively long. Available in standard roller or carrier roller type.

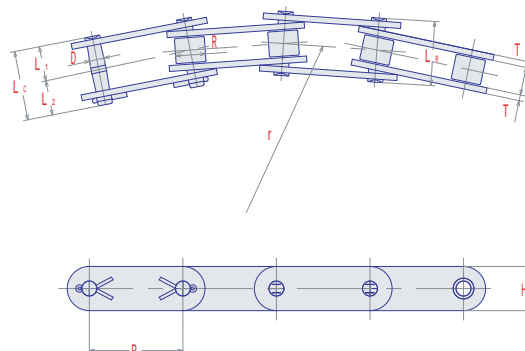

SB DOUBLE PITCH

SY Chain No.	Dimensions - mm											Average Ultimate Strength kN	Maximum Allowable Load kN	Average Chain Weight kg/m
	Pitch P	Roller		Pin				Plate		Min. Curve Radius r				
		Width W	Dia. R	Out Dia. D	Length		Height H	Thick. T						
C2040-SB	25.40	7.95	7.92	3.96	16.9	18.9	8.5	10.4	11.4	1.5	700	14.9	1.77	0.48
C2050-SB	31.75	9.53	10.16	5.08	21.1	23.1	10.6	12.5	15.0	2.0	800	22.1	3.14	0.82
C2060-SB	38.10	12.70	11.91	5.95	26.3	28.1	13.2	14.9	17.0	2.4	1000	29.4	4.22	1.20
C2042-SB	25.40	7.95	15.88	3.96	16.9	18.9	8.5	10.4	11.4	1.5	700	14.9	1.77	0.82
C2052-SB	31.75	9.53	19.05	5.08	21.1	23.1	10.6	12.5	15.0	2.0	800	22.1	3.14	1.26
C2062-SB	38.10	12.70	22.23	5.95	26.3	28.1	13.2	14.9	17.0	2.4	1000	29.4	4.22	2.01

HOLLOW PIN CHAINS

SY Hollow pin chains are identical to ANSI roller chains, and run on standard ANSI sprockets. The unique hollow pin feature provides unlimited conveyor versatility, allowing easy insertion of cross rods or attachments to pre-assembled chain at desired spacing. For identification, the suffix HP is added to the chain numbers.

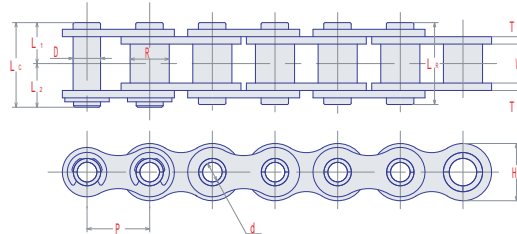

HP STANDARD

SY Chain No.	Dimensions - mm											Average Ultimate Strength	Maximum Allowable Load	Average Chain Weight
	Pitch	Roller		Hollow Pin						Plate				
		Width	Dia.	Outside	Inside	Length				Height	Thick.			
P	W	R	D	d	LR	Lc	L1	L2	H	T	kN	kN	kg/m	
SY40-HP	12.70	7.95	7.92	5.63	4.03	16.7	17.6	8.4	9.2	12.0	1.5	12.7	1.77	0.58
SY50-HP	15.875	9.53	10.16	7.09	5.13	20.1	21.3	10.1	11.2	15.0	2.0	19.6	3.14	0.97
SY60-HP	19.05	12.70	11.91	8.29	6.04	26.0	27.2	13.0	14.2	18.1	2.4	28.4	4.22	1.46
SY80-HP	25.40	15.88	15.88	11.34	8.08	32.4	34.3	16.2	18.1	24.1	3.2	51.0	7.65	2.47

HP standard are rollerless; R given above shows bushing dia.

DOUBLE PITCH HOLLOW PIN CHAINS

SY Hollow pin chains with oil less parts are quality chains functioning rationally, combining both advantages of hollow pin chains and self-lube chains. Available on the same sprockets as double-pitch roller chains.

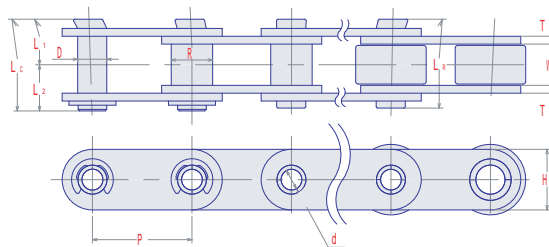

HP DOUBLE PITCH

SY Chain No.	Dimensions - mm											Average Ultimate Strength	Maximum Allowable Load	Average Chain Weight
	Pitch	Roller		Hollow Pin						Plate				
		Width	Dia.	Outside	Inside	Length				Height	Thick.			
P	W	R	D	d	LR	Lc	L1	L2	H	T	kN	kN	kg/m	
C2040-HP	25.40	7.95	7.92	5.63	4.03	16.7	17.6	8.4	9.2	12.0	1.5	12.7	1.77	0.46
C2050-HP	31.75	9.53	10.16	7.09	5.13	20.1	21.3	10.1	11.2	15.0	2.0	19.6	3.14	0.76
C2060-HP	38.10	12.70	11.91	8.29	6.04	26.0	27.2	13.0	14.2	18.1	2.4	28.4	4.22	1.12
C2080-HP	50.80	15.88	15.88	11.34	8.08	32.4	34.3	16.2	18.1	24.1	3.2	51.0	7.65	1.98
C2042-HP	25.40	7.95	15.88	5.63	4.03	16.7	17.6	8.4	9.2	12.0	1.5	12.7	1.77	0.81
C2052-HP	31.75	9.53	19.05	7.09	5.13	20.1	21.3	10.1	11.2	15.0	2.0	19.6	3.14	1.25
C2062-HP	38.10	12.70	22.23	8.29	6.04	26.0	27.2	13.0	14.2	18.1	2.4	28.4	4.22	1.79
C2082-HP	50.80	15.88	28.58	11.34	8.08	32.4	34.3	16.2	18.1	24.1	3.2	51.0	7.65	3.17
C2082H-HP	50.80	15.88	28.58	11.34	8.08	35.8	37.7	17.9	19.8	24.1	4.0	58.0	7.65	3.22

SY Chains C2040-HP thru C2080-HP are rollerless; R given above shows bushing dia.

HOLLOW PIN CHAINS

Stainless Hollow Pin Chains

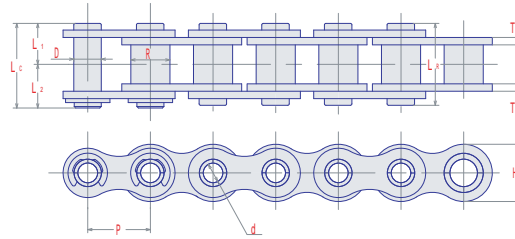

HP-SS STANDARD

SY Chain No.	Dimensions - mm											Average Ultimate Strength	Maximum Allowable Load	Average Chain Weight
	Pitch	Roller		Pin						Plate				
		Width	Dia.	Outside	Inside	Length				Height	Thick.			
P	W	R	D	d	LR	LC	L1	L2	H	T	kN	kN	kg/m	
40HP-SS	12.70	7.95	7.92	5.63	4.03	16.7	17.6	8.4	9.2	12.0	1.5	7.65	0.44	0.58
50HP-SS	15.875	9.53	10.16	7.09	5.13	20.1	21.3	10.1	11.2	15.0	2.0	11.8	0.69	0.97
60HP-SS	19.05	12.70	11.91	8.29	6.04	26.0	27.2	13.0	14.2	18.1	2.4	17.1	1.03	1.46
80HP-SS	25.40	15.88	15.88	11.34	8.08	32.4	34.3	16.2	18.1	24.1	3.2	31.0	1.77	2.47

HP standard are rollerless; R given above shows bushing dia.

Double Pitch Stainless Hollow Pin Chains

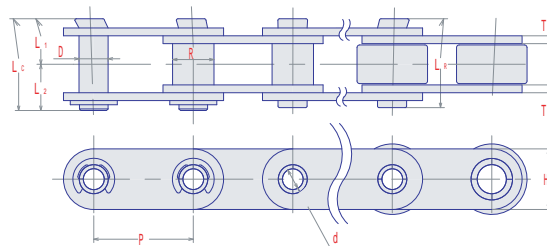

HP-SS DOUBLE PITCH

SY Chain No.	Dimensions - mm											Average Ultimate Strength	Maximum Allowable Load	Average Chain Weight
	Pitch	Roller		Pin						Plate				
		Width	Dia.	Outside	Inside	Length				Height	Thick.			
P	W	R	D	d	LR	LC	L1	L2	H	T	kN	kN	kg/m	
C2040HP-SS	25.40	7.95	7.92	5.63	4.03	16.7	17.6	8.4	9.2	12.0	1.5	7.65	0.44	0.46
C2050HP-SS	31.75	9.53	10.16	7.09	5.13	20.1	21.3	10.1	11.2	15.0	2.0	11.8	0.69	0.76
C2060HP-SS	38.10	12.70	11.91	8.29	6.04	26.0	27.2	13.0	14.2	18.1	2.4	17.1	1.03	1.12
C2080HP-SS	50.80	15.88	15.88	11.34	8.08	32.4	34.3	16.2	18.1	24.1	3.2	31.0	1.77	1.98
C2042HP-SS	25.40	7.95	15.88	5.63	4.03	16.7	17.6	8.4	9.2	12.0	1.5	7.65	0.44	0.81
C2052HP-SS	31.75	9.53	19.05	7.09	5.13	20.1	21.3	10.1	11.2	15.0	2.0	11.8	0.69	1.25
C2062HP-SS	38.10	12.70	22.23	8.29	6.04	26.0	27.2	13.0	14.2	18.1	2.4	17.1	1.03	1.79
C2082HP-SS	50.80	15.88	28.58	11.34	8.08	32.4	34.3	16.2	18.1	24.1	3.2	31.0	1.77	3.17
C2082H-HP-SS	50.80	15.88	28.58	11.34	8.08	35.8	37.7	17.9	19.8	24.1	4.0	31.0	1.77	3.22

SY Chains C2040-HP thru C2080-HP are rollerless; R given above shows bushing dia.

Sintered Steel Bushing Self-Lube Chains

Oil-impregnated sintered steel bushing roller chain is self-lubricating. No additional lubrication is necessary. SL type self-lube chain is made with a one-piece sintered bushing, i.e. bushed chain. The extra solid volume of the bushing offers longer life capacity, compared to SLR type chain. The SLR is a self-lube chain with rollers to reduce friction and to smooth the action of the chain over the sprockets. These are two types of SLR chain: one, with an inner link plate thickness that is of the next larger size chain to maintain the same strength of standard roller chain; and another with the same thickness of the standard link plate that provides approximately 80% of the maximum allowable load of standard roller chain.

(Chain size)	#40 - #120SL #40 - #120SLR and 08B - 32B SLR
(Sprocket)	Standard size
(Other applicable chains)	Hollow Pin Chain, Attachment Chain
(Operating temperature)	- 10 to + 60
(Range of speed)	From slow speed 25m/min to high speed 75m/min

(Selection and Caution)

- 1) In dusty environments, dusts absorb the lubrication of sintered steel bushings resulting in premature wear.
- 2) Used in water, the chain wears quickly.
- 3) When lubrication depletes in the sintered steel bushing, the chain wears abruptly.
- 4) When ambient temperature is over 80 °C, lubrication seeps out quickly.
- 5) The sintered bushings are heat-treated, and allow standard chain selection.
- 6) Due to the use of sintered steel bushing, an application associated with shock load is not appropriate.



SL Standard Chain



SLR Standard Chain

Sintered Steel Bushing SL ANSI Standard Roller Chains

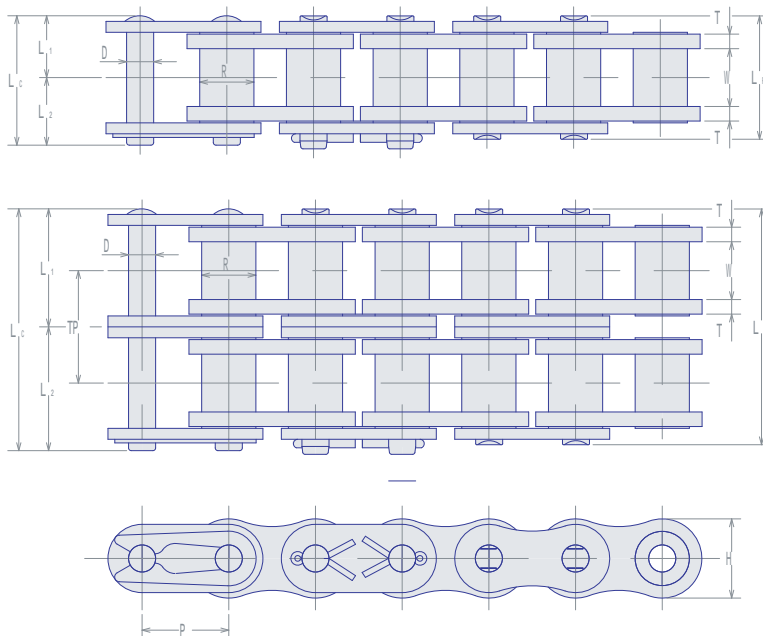

SINGLE STRANDS

SY Chain No.	Dimensions - mm											Average Ultimate Strength	Maximum Allowable Load	Average Chain Weight
	Pitch	Roller		Pin				Plate		Trans. Pitch				
		Width	Dia.	Dia.	Length				Height		Thick.			
P	W	R	D	LR	LC	L1	L2	H	T	TP	kN	kN	kg/m	
SY40-SL	12.70	7.7	7.92	3.96	16.5	17.9	8.3	9.6	12.0	1.5		12.7	2.94	0.63
SY50-SL	15.875	9.4	10.16	5.08	20.4	22.0	10.2	11.8	15.1	2.0		19.6	4.90	1.03
SY60-SL	19.05	12.5	11.91	5.95	25.5	26.9	12.8	14.1	18.2	2.4		28.4	6.86	1.46
SY80-SL	25.40	15.8	15.88	7.93	32.8	35.5	16.4	18.6	24.1	3.2		51.0	11.8	2.60
SY100-SL	31.75	19.0	19.05	9.53	39.4	43.0	19.7	23.3	30.2	4.0		82.4	17.7	3.79
SY120-SL	38.10	25.4	22.23	11.10	49.5	53.4	24.8	28.6	36.2	4.8		118.0	25.5	5.58
SY140-SL	44.45	25.4	25.40	12.70	54.0	58.3	27.0	31.3	42.2	5.6		162.0	34.3	7.59
SY160-SL	50.80	31.8	28.58	14.28	64.3	68.7	32.2	36.5	48.3	6.4		211.0	44.1	9.82

MULTIPLE STRANDS

SY Chain No.	Dimensions - mm											Average Ultimate Strength	Maximum Allowable Load	Average Chain Weight
	Pitch	Roller		Pin				Plate		Trans. Pitch				
		Width	Dia.	Dia.	Length				Height		Thick.			
P	W	R	D	LR	LC	L1	L2	H	T	TP	kN	kN	kg/m	
SY40-SL-2	12.70	7.7	7.92	3.96	30.8	32.2	15.4	16.8	12.0	1.5	14.4	25.4	5.0	1.3
SY50-SL-2	15.875	9.4	10.16	5.08	38.4	40.0	19.2	20.8	15.1	2.0	18.1	39.2	8.3	2.1
SY60-SL-2	19.05	12.5	11.91	5.95	48.2	49.7	24.0	25.7	18.2	2.4	22.8	56.8	11.6	3.0
SY80-SL-2	25.40	15.8	15.88	7.93	61.6	64.5	30.8	33.7	24.1	3.2	29.3	102.0	20.0	5.2
SY100-SL-2	31.75	19.0	19.05	9.53	75.1	78.8	37.6	41.2	30.2	4.0	35.8	164.8	30.0	7.9
SY120-SL-2	38.10	25.4	22.23	11.10	94.9	98.8	47.5	51.3	36.2	4.8	45.4	236.0	43.3	11.5
SY140-SL-2	44.45	25.4	25.40	12.70	102.9	107.2	51.5	55.7	42.2	5.6	48.9	324.0	58.3	14.7
SY160-SL-2	50.80	31.8	28.58	14.28	122.8	127.2	61.4	65.6	48.3	6.4	58.5	422.0	75.0	19.5

Sintered Steel Bushing SL Double Pitch Roller Chains

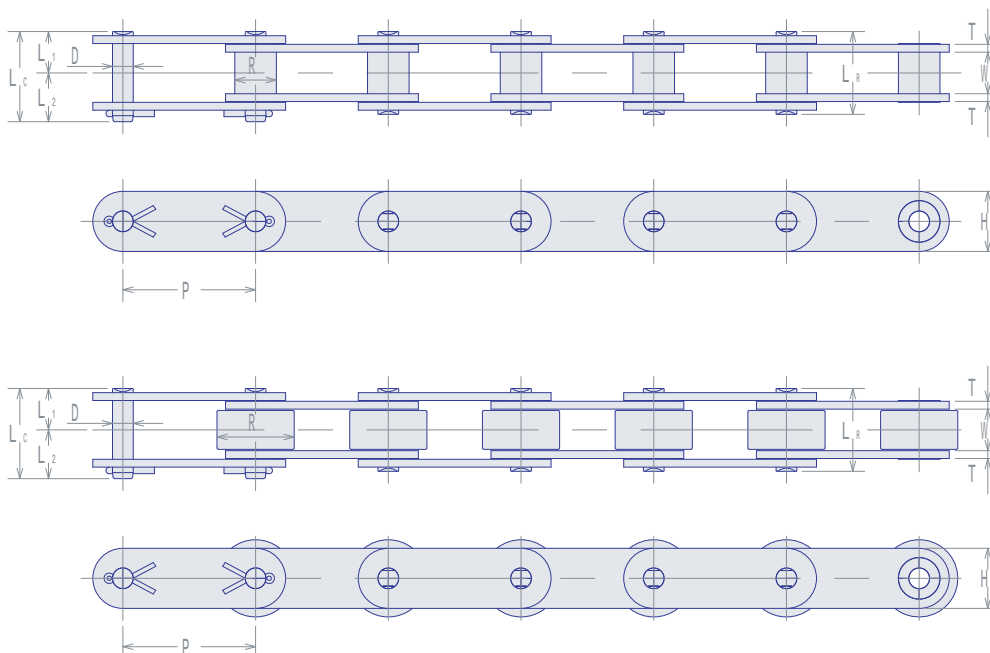

CONVEYOR SERIES (STANDARD ROLLER TYPE)

SY Chain No.	Dimensions - mm										Average Ultimate Strength	Maximum Allowable Load	Average Chain Weight
	Pitch	Roller		Pin				Plate					
		Width	Dia.	Dia.	Length			Height	Thick.				
		P	W	R	D	LR	LC	L1	L2	H			
C 2040-SL	25.40	7.95	7.92	3.96	16.5	17.9	8.3	9.6	12.0	1.5	12.7	2.94	0.48
C 2050-SL	31.75	9.53	10.16	5.08	20.4	22.0	10.2	11.8	15.0	2.0	19.6	4.90	0.82
C 2060-SL	38.10	12.70	11.91	5.95	25.5	26.9	12.8	14.1	18.1	2.4	28.4	6.86	1.20
C 2080-SL	50.80	15.88	15.88	7.93	32.8	35.0	16.4	18.6	24.1	3.2	51.0	11.8	1.99

CONVEYOR SERIES (CARRIER ROLLER TYPE)

SY Chain No.	Dimensions - mm										Average Ultimate Strength	Maximum Allowable Load	Average Chain Weight
	Pitch	Roller		Pin				Plate					
		Width	Dia.	Dia.	Length			Height	Thick.				
		P	W	R	D	LR	LC	L1	L2	H			
C 2042-SL	25.40	7.95	15.88	3.96	16.5	17.9	8.3	9.6	12.0	1.5	12.7	2.94	0.82
C 2052-SL	31.75	9.53	19.05	5.08	20.4	22.0	10.2	11.8	15.0	2.0	19.6	4.90	1.26
C 2062-SL	38.10	12.70	22.23	5.95	25.5	26.9	12.8	14.1	18.1	2.4	28.4	6.86	1.78
C 2082-SL	50.80	15.88	28.58	7.93	32.8	35.0	16.4	18.6	24.1	3.2	51.0	11.8	3.03

Sintered Steel Bushing SLR BS Standard Roller Chains

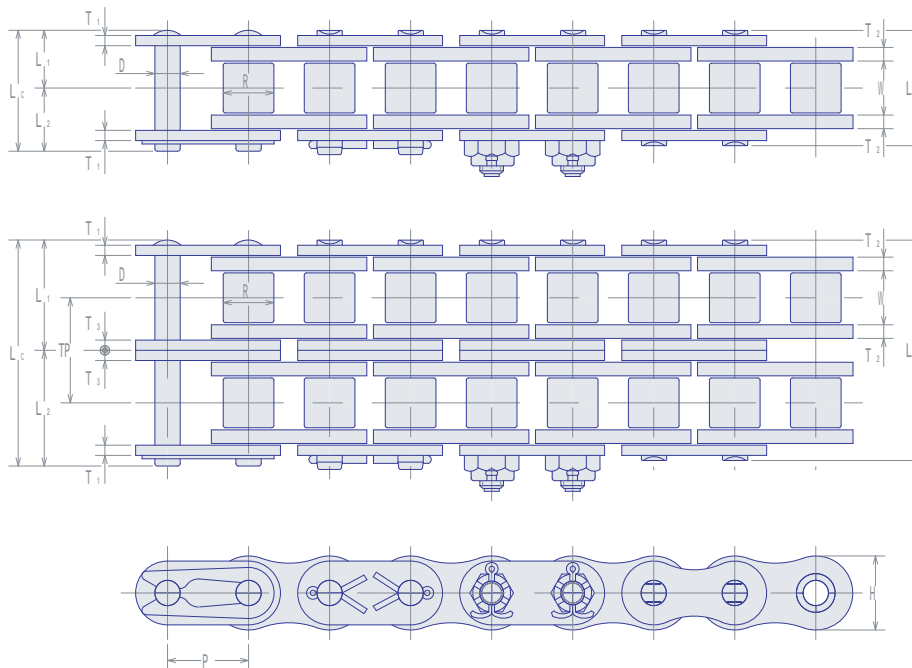

SINGLE STRANDS

SY Chain No.	Dimensions - mm													Average Ultimate Strength kN	Maximum Allowable Load kN	Average Chain Weight kg/m
	Pitch P	Roller		Pin				Plate			Trans. Pitch TP					
		Width W	Dia. R	Dia. D	Length				Height H	Thickness						
08B-SLR	12.70	7.75	8.51	4.45	16.7	18.0	8.4	9.6	11.8	1.5	1.5			16.8	2.9	0.6
10B-SLR	15.875	9.65	10.16	5.08	19.0	20.7	9.5	11.2	14.5	1.65	1.65			24.6	4.4	0.9
12B-SLR	19.05	11.68	12.07	5.72	22.0	23.6	11.0	12.6	17.4	1.8	1.8			32.4	6.3	1.1
16B-SLR	25.40	17.02	15.87	8.26	35.1	38.2	17.6	20.5	21.0	3.1	3.9			74.6	12.2	2.6
20B-SLR	31.75	19.56	19.05	10.16	40.2	44.0	20.1	23.9	29.3	3.5	4.7			128.3	19.1	3.8
24B-SLR	38.10	25.40	25.40	14.63	53.4	58.1	26.7	31.4	35.1	4.7	5.9			195.6	25.5	7.3
28B-SLR	44.45	31.00	27.94	15.88	65.1	70.5	32.6	37.9	37.0	6.3	7.4			215.7	34.8	9.3
32B-SLR	50.80	31.00	29.21	17.81	64.2	69.6	32.1	37.5	42.2	6.3	6.9			274.6	44.1	9.9

MULTIPLE STRANDS

SY Chain No.	Dimensions - mm													Average Ultimate Strength kN	Maximum Allowable Load kN	Average Chain Weight kg/m
	Pitch P	Roller		Pin				Plate			Trans. Pitch TP					
		Width W	Dia. R	Dia. D	Length				Height H	Thickness						
08B-SLR-2	12.70	7.75	8.51	4.45	30.6	31.9	15.3	16.6	11.8	1.5	1.5	1.25	13.92	33.6	5.0	1.3
10B-SLR-2	15.875	9.65	10.16	5.08	35.6	37.3	17.8	19.5	14.5	1.65	1.65	1.65	16.59	49.2	7.5	1.8
12B-SLR-2	19.05	11.68	12.07	5.72	41.6	43.1	20.8	22.3	17.4	1.8	1.8	1.8	19.46	64.8	10.8	2.9
16B-SLR-2	25.40	17.02	15.87	8.26	67.2	70.1	33.6	36.5	21.0	3.1	3.9	3.1	31.88	149.2	20.7	5.1
20B-SLR-2	31.75	19.56	19.05	10.16	76.8	80.6	38.4	42.2	29.3	3.5	4.7	3.5	36.45	256.6	32.4	7.3
24B-SLR-2	38.10	25.40	25.40	14.63	101.8	106.5	50.9	55.6	35.1	4.7	5.9	4.7	48.36	391.2	43.3	14.5
28B-SLR-2	44.45	31.00	27.94	15.88	124.7	130.0	62.4	67.6	37.0	6.3	7.4	4.7	59.56	431.4	59.1	18.5
32B-SLR-2	50.80	31.00	29.21	17.81	123.6	129.2	61.8	67.4	42.2	6.3	6.9	4.7	58.55	549.2	74.7	19.8

Sintered Steel Bushing SLR ANSI Standard Roller Chains (T.S)

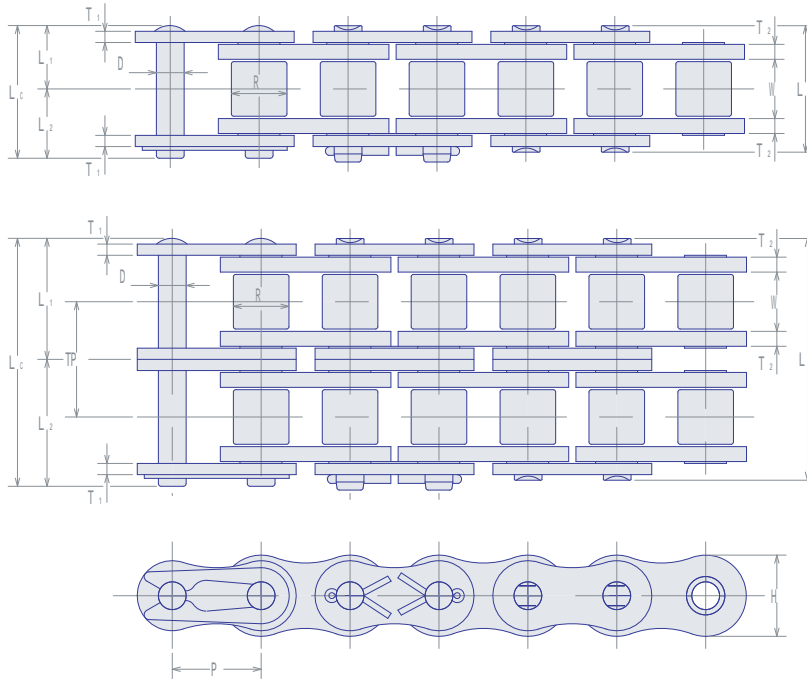

SINGLE STRANDS

SY Chain No.	Dimensions - mm												Average Ultimate Strength kN	Maximum Allowable Load kN	Average Chain Weight kg/m
	Pitch P	Roller		Pin				Plate		Trans. Pitch TP					
		Width W	Dia. R	Dia. D	Length		Height H	Thickness							
				LR	Lc	L1	L2		T1	T2					
SY40-SLR	12.70	7.95	7.92	3.96	17.5	19.0	8.8	10.2	11.7	1.5	2.0		19.1	3.63	0.7
SY50-SLR	15.875	9.53	10.16	5.08	21.3	23.0	10.7	12.3	14.6	2.0	2.4		31.9	6.28	1.1
SY60-SLR	19.05	12.70	11.91	5.95	27.4	29.0	13.7	15.3	17.5	2.4	3.2		43.1	8.63	1.7
SY80-SLR	25.40	15.88	15.88	7.93	34.1	37.4	17.1	20.3	23.4	3.2	4.0		78.5	14.7	2.7
SY100-SLR	31.75	19.05	19.08	9.53	41.0	44.8	20.5	24.3	29.3	4.0	4.8		118	22.6	4.3
SY120-SLR	38.10	25.40	22.23	11.10	51.1	55.2	25.6	29.6	35.1	4.8	5.6		167	30.4	6.0

MLTIPLE STRANDS

SY Chain No.	Dimensions - mm												Average Ultimate Strength kN	Maximum Allowable Load kN	Average Chain Weight kg/m
	Pitch P	Roller		Pin				Plate		Trans. Pitch TP					
		Width W	Dia. R	Dia. D	Length		Height H	Thickness							
				LR	Lc	L1	L2		T1	T2					
SY40-SLR-2	12.70	7.95	7.92	3.96	33.1	34.6	16.6	18	11.7	1.5	2.0	15.6	3.82	6.17	1.3
SY50-SLR-2	15.875	9.53	10.16	5.08	40.5	42.2	20.3	21.9	14.6	2.0	2.4	19.2	63.8	10.7	2.0
SY60-SLR-2	19.05	12.70	11.91	5.95	52.3	53.9	26.2	27.7	17.5	2.4	3.2	24.9	86.2	14.7	3.3
SY80-SLR-2	25.40	15.88	15.88	7.93	65.2	68.5	32.6	35.9	23.4	3.2	4.0	31.1	157	25.0	5.1
SY100-SLR-2	31.75	19.05	19.08	9.53	78.6	82.4	39.3	43.1	29.3	4.0	4.8	37.6	236	38.4	8.2
SY120-SLR-2	38.10	25.40	22.23	11.10	99.1	103.2	49.6	53.6	35.1	4.8	5.6	48.0	334	51.7	11.7

Sintered Steel Bushing SLR ANSI Standard Roller Chains (C.S)

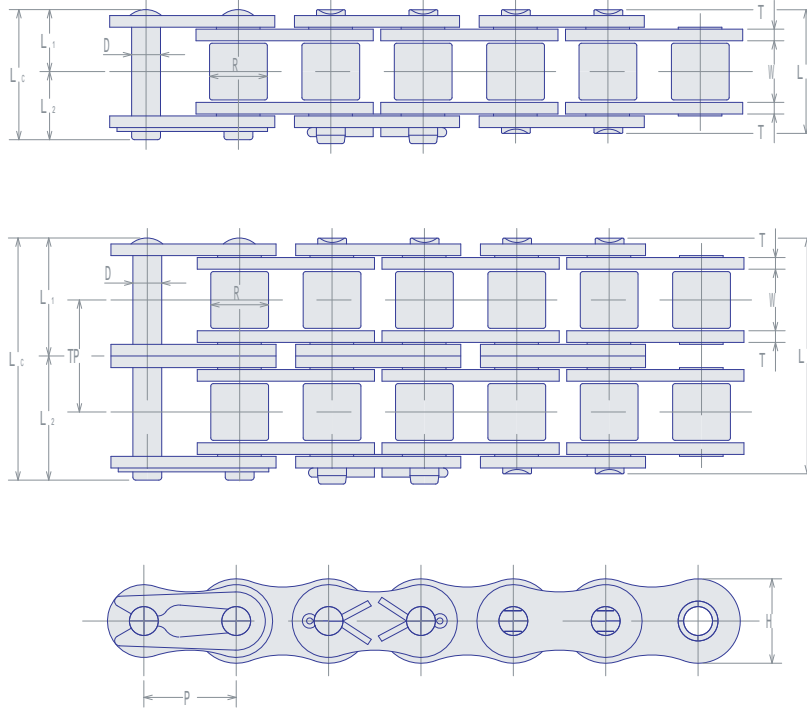

SINGLE STRANDS

SY Chain No.	Dimensions - mm											Average Ultimate Strength	Maximum Allowable Load	Average Chain Weight
	Pitch	Roller		Pin				Plate		Trans. Pitch				
		Width	Dia.	Dia.	Length				Height		Thick.			
		P	W	R	D	LR	LC	L1	L2		H			
SY40-SLR	12.70	7.95	7.92	3.96	16.5	18.1	8.3	9.8	11.7	1.5		15.7	3.62	0.6
SY50-SLR	15.875	9.53	10.16	5.08	20.5	22.3	10.3	12.0	14.6	2.0		25.5	6.27	1.0
SY60-SLR	19.05	12.70	11.91	5.95	25.9	27.5	13.0	14.5	17.5	2.4		37.3	8.63	1.5
SY80-SLR	25.40	15.88	15.88	7.93	33.0	35.9	16.5	19.4	23.4	3.2		63.7	14.7	2.5
SY100-SLR	31.75	19.05	19.08	9.53	39.8	43.1	19.9	23.2	29.3	4.0		100	22.5	3.9
SY120-SLR	38.10	25.40	22.23	11.10	49.8	53.2	24.9	28.3	35.1	4.8		157	30.4	5.8

MULTIPLE STRANDS

SY Chain No.	Dimensions - mm											Average Ultimate Strength	Maximum Allowable Load	Average Chain Weight
	Pitch	Roller		Pin				Plate		Trans. Pitch				
		Width	Dia.	Dia.	Length				Height		Thick.			
		P	W	R	D	LR	LC	L1	L2		H			
SY40-SLR-2	12.70	7.95	7.92	3.96	31.1	32.7	15.6	17.1	11.7	1.5	14.4	31.4	6.3	1.1
SY50-SLR-2	15.875	9.53	10.16	5.08	39.1	40.7	19.6	21.1	14.6	2.0	18.1	51.0	10.6	1.9
SY60-SLR-2	19.05	12.70	11.91	5.95	49.3	50.9	24.7	26.2	17.5	2.4	22.8	54.6	15.1	2.8
SY80-SLR-2	25.40	15.88	15.88	7.93	62.2	65.5	31.1	34.4	23.4	3.2	29.3	127	25.7	4.9
SY100-SLR-2	31.75	19.05	19.08	9.53	75.4	79.1	37.7	41.4	29.3	4.0	35.8	200	39.3	7.6
SY120-SLR-2	38.10	25.40	22.23	11.10	95.4	99.6	47.7	51.9	35.1	4.8	45.4	314	53.2	11.1

Sintered Steel Bushing SLR Double Pitch Roller Chains

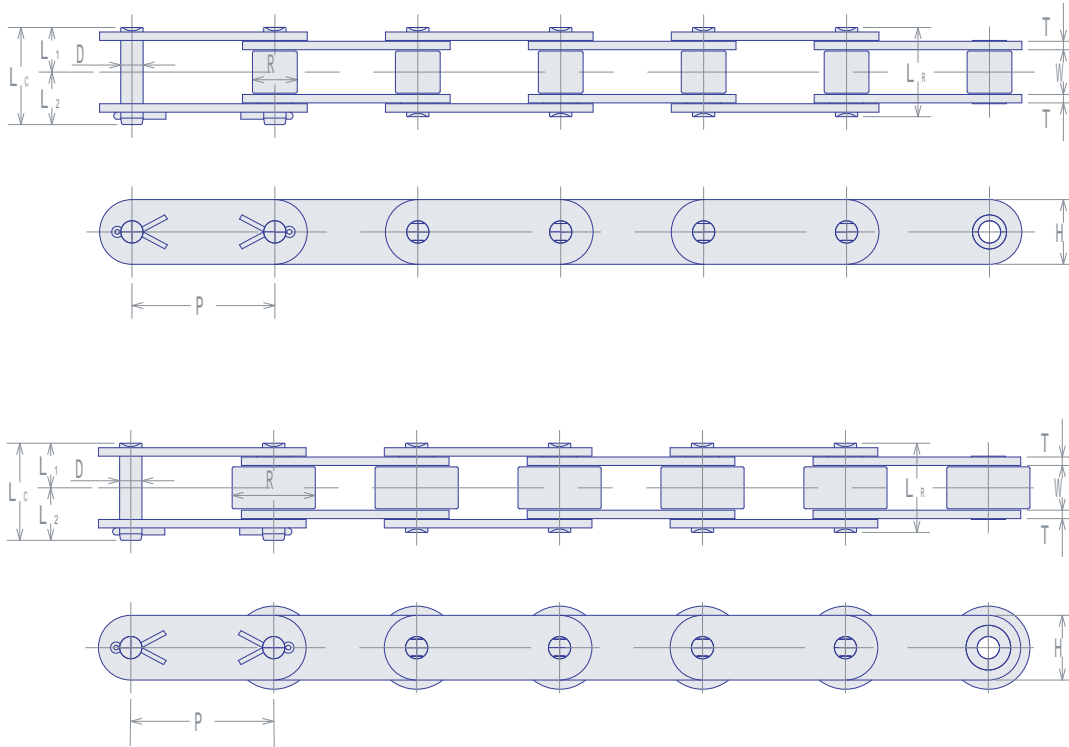

CONVEYOR SERIES (STANDARD ROLLER TYPE)

SY Chain No.	Dimensions - mm										Average Ultimate Strength	Maximum Allowable Load	Average Chain Weight
	Pitch	Roller		Pin				Plate					
		Width	Dia.	Dia.	Length			Height	Thick.				
		P	W	R	D	LR	LC	L1	L2	H			
C 2040-SLR	25.40	7.95	7.92	3.96	16.5	18.5	8.3	10.2	11.5	1.5	15.7	2.65	0.5
C 2050-SLR	31.75	9.53	10.16	5.08	20.5	22.5	10.3	12.2	15.1	2.0	25.5	4.31	0.8
C 2060H-SLR	38.10	12.70	11.91	5.95	29.1	31.5	14.6	16.9	17.2	3.2	37.3	6.28	1.4
C 2080H-SLR	50.80	15.88	15.88	7.93	35.8	39.0	17.9	21.1	22.8	4.0	63.7	10.7	2.4
C 2100H-SLR	63.50	19.05	19.05	9.53	42.7	46.6	21.4	25.2	28.8	4.8	100	17.1	3.5

CONVEYOR SERIES (CARRIER ROLLER TYPE)

SY Chain No.	Dimensions - mm										Average Ultimate Strength	Maximum Allowable Load	Average Chain Weight
	Pitch	Roller		Pin				Plate					
		Width	Dia.	Dia.	Length			Height	Thick.				
		P	W	R	D	LR	LC	L1	L2	H			
C 2042-SLR	25.40	7.95	7.92	3.96	16.5	18.5	8.3	10.2	11.5	1.5	31.4	4.50	1.0
C 2052-SLR	31.75	9.53	10.16	5.08	20.5	22.5	10.3	12.2	15.1	2.0	51.0	7.30	1.6
C 2062H-SLR	38.10	12.70	11.91	5.95	29.1	31.5	14.6	16.9	17.2	3.2	74.6	10.6	2.8
C 2082H-SLR	50.80	15.88	15.88	7.93	35.8	39.0	17.9	21.1	22.8	4.0	127	18.1	4.6
C 2102H-SLR	63.50	19.05	19.05	9.53	42.7	46.6	21.4	25.2	28.8	4.8	200	29.0	6.9

MAINTENANCE FREE CHAINS

Sintered Steel Bushing HB-type Hollow Pin Chains

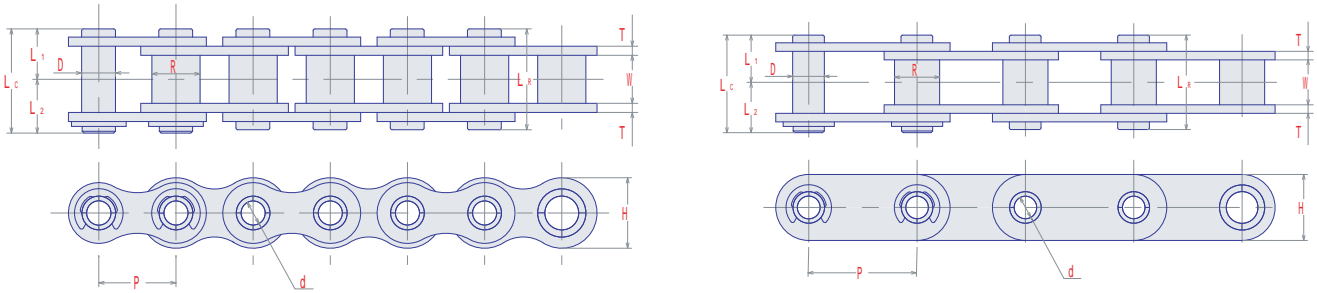

HP-SS DOUBLE PITCH

SY Chain No.	Dimensions - mm											Average Ultimate Strength	Maximum Allowable Load	Average Chain Weight
	Pitch	Roller		Pin						Plate				
		Width	Dia.	Outside	Inside	Length				Height	Thick.			
P	W	R	D	d	LR	Lc	L1	L2	H	T	kN	kN	kg/m	
HB40-SL	12.70	7.95	7.92	5.63	4.03	16.7	17.6	8.4	9.2	12.0	1.5	12.7	1.77	0.6
HB50-SL	15.875	9.53	10.16	7.09	5.13	20.1	21.5	10.1	11.2	15.0	2.0	19.6	3.14	1.0
HB60-SL	19.05	12.70	11.91	8.29	6.04	26.0	27.2	13.0	14.2	18.1	2.4	28.4	4.22	1.5
HB80-SL	25.40	15.88	15.88	11.34	8.08	32.4	34.3	16.2	18.1	24.1	3.2	51.0	7.65	2.5
HB2040-SL	25.40	7.95	7.92	5.63	4.03	16.7	17.6	8.4	9.2	12.0	1.5	12.7	1.77	0.5
HB2050-SL	31.75	9.53	10.16	7.09	5.13	20.1	21.5	10.1	11.2	15.0	2.0	19.6	3.14	0.8
HB2060-SL	38.10	12.70	11.91	8.29	6.04	26.0	27.2	13.0	14.2	18.1	2.4	28.4	4.22	1.1
HB2080-SL	50.80	15.88	15.88	11.34	8.08	32.4	34.3	16.2	18.1	24.1	3.2	51.0	7.65	2.0

Sintered Steel Bushing HR-type Hollow Pin Chains

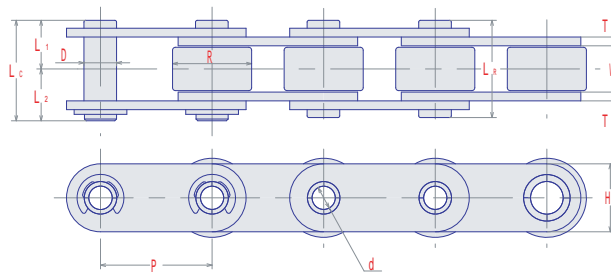

HR-TYPE HOLLOW PIN CHAINS

SY Chain No.	Dimensions - mm											Average Ultimate Strength	Maximum Allowable Load	Average Chain Weight
	Pitch	Roller		Pin						Plate				
		Width	Dia.	Outside	Inside	Length				Height	Thick.			
P	W	R	D	d	LR	Lc	L1	L2	H	T	kN	kN	kg/m	
HR2042-SL	25.40	7.95	15.88	5.63	4.03	16.7	17.6	8.4	9.2	12.0	1.5	12.7	1.77	0.8
HR2052-SL	31.75	9.53	19.05	7.09	5.13	20.1	21.5	10.1	11.2	15.0	2.0	19.6	3.14	1.3
HR2062-SL	38.10	12.70	22.23	8.29	6.04	26.0	27.2	13.0	14.2	18.1	2.4	28.4	4.22	1.8
HR2082-SL	50.80	15.88	28.58	11.34	8.08	32.4	34.3	16.2	18.1	24.1	3.2	51.0	7.65	3.2

Maintenance Free Roller Chains

The chain is designed to hold high quality lubricant between the pin and bushing with seals. Expanded applications are now possible from low to high speed, light to heavy load, and where lubrication is not possible. This chain can drive for many hours without lubrication. Sales schedule will be in spring of 2004.

(Chain size)	#80 - #240 and 16B - 48B
(Sprocket)	Standard size
(Other applicable chains)	Attachment chains
(Operating temperature)	- 10 to + 60 (Special order up to max. 150)
(Range of speed)	From slow speed 25m/min to high speed 150m/min

(Selection and Caution)

- 1) Standard Sprocket is used. Note, however, the overall width of chain is slightly wider. Take this into consideration for designing.
- 2) When connecting the chain, make sure that all four (4) seals are installed.
- 3) Lubricate connecting link with ample lubrication before assembly.
- 4) When a lubrication leak is found (even at one location), replace that link immediately.
- 5) The maximum chain elongation limit is 1.5% of the chain length.
- 6) For use of chain in ambient temperature over 80 , special lubrication for higher temperature is available upon request.
- 7) The covering plate of connecting link is a press-fit type with extra interferences.
- 8) An offset link is not available.

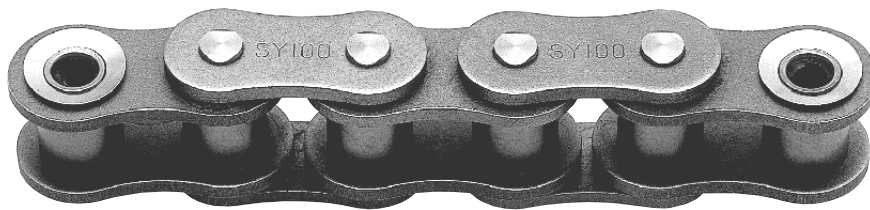

Maintenance Free Roller Chains

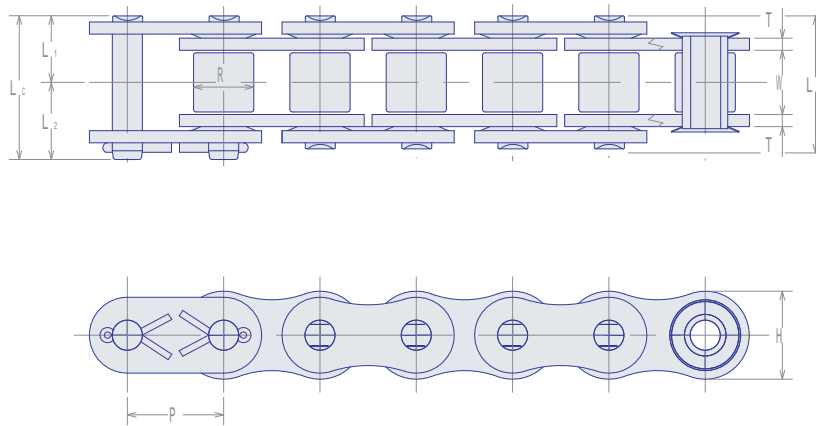

SY Chain No.	Dimensions - mm									Average Ultimate Strength	Maximum Allowable Load	Average Chain Weight
	Pitch	Roller		Length				Plate				
		Width	Dia.	LR	LC	L1	L2	Height	Thick			
	P	W	R					H	T			
MF 16A	25.40	15.9	15.88	34.8	37.5	17.4	20.1	23.4	3.2	78.5	18.4	2.6
MF 16B	25.40	17.1	15.88	35.8	38.5	17.9	20.6	23.4	3.2	78.5	18.4	2.7
MF 20AB	31.75	19.6	19.05	41.6	45.2	20.8	24.4	29.3	4.0	118	28.3	3.9
MF 24A	38.10	25.4	22.23	51.8	55.7	25.9	29.8	35.1	4.8	164	38.0	5.8
MF 24B	38.10	25.4	25.40	51.8	55.7	25.9	29.8	35.1	4.8	167	38.0	7.3
MF 28A	44.45	25.4	25.40	56.2	60.5	28.1	32.4	40.9	5.6	216	50.3	7.5
MF 28B	44.45	31.0	27.94	61.8	66.1	30.9	35.2	40.9	5.6	216	50.3	9.3
MF 32AB	50.80	31.6	28.58	66.6	71.0	33.3	37.7	46.7	6.4	275	66.3	9.8
MF 40AB	63.50	38.1	39.37	82.0	90.5	41.0	49.5	59.6	8.0	451	82.3	16.9
MF 48AB	76.20	47.5	47.63	100.0	107.7	50.0	57.7	70.3	9.5	677	112.8	23.6

Leaf Chains

SY Leaf chains are well suited for any application requiring flexible, high strength linkage for reciprocating motion or lift at relatively low speed. For their low cost and long life, widely used for lift trucks, masts and other lifting as construction and mining machines and excellent as balance and counterweights of machine tools and so forth.

CONSTRUCTION AND LACING COMBINATIONS

Built of interlaced plates held together by riveted pins. The chain nomenclature indicates the lacing combinations.

AL SERIES (LIGHT DUTY)

Consisting of link plates of the same contour and thickness as the pin link plates of ANSI roller chains in same pitch. Mainly used for relatively constant, low, medium load with less shock.

BL SERIES (HEAVY DUTY)

Consisting of link plates with next large size pitch chain of ANSI roller chains. Chiefly used for medium load with greater shock.

LL SERIES (ISO 606)

Consisting of link plates of the same contour and thickness as the pin link plates of BS roller chains

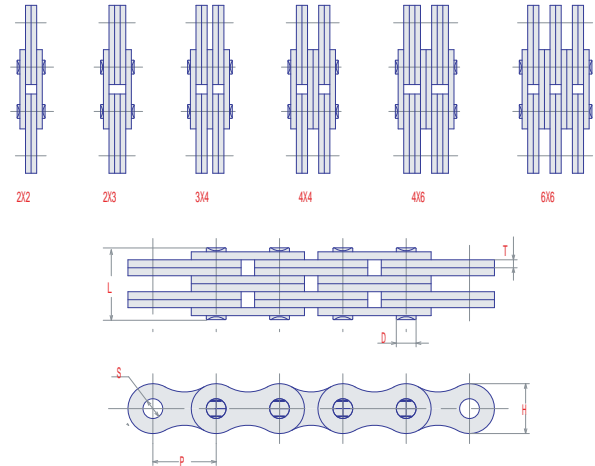

SY Chain No.	Lacing	Dimensions - mm						Average Ultimate Strength	Maximum Allowable Load	Average Weight
		Pitch	Pin		Plate		Hole Dia			
			Dia.	Length	Height	Thickness				
P	D	L	H	T	S	kN	kN	kg/m		
AL422	2 × 2	12.70	3.96	8.4	10.3	1.5	4.03	18.6	1.86	0.36
AL444	4 × 4			14.6				37.3	3.43	0.70
AL466	6 × 6			21.2				55.9	3.92	1.04
AL522	2 × 2	15.875	5.08	10.5	12.7	2.0	5.15	30.4	3.04	0.58
AL544	4 × 4			19.0				60.8	5.30	1.16
AL566	6 × 6			27.6				94.1	6.28	1.73
AL622	2 × 2	19.05	5.95	12.4	15.2	2.4	6.04	43.1	4.41	0.81
AL644	4 × 4			22.2				86.3	7.45	1.68
AL666	6 × 6			32.6				129	8.73	2.46
AL822	2 × 2	25.40	7.93	16.6	20.2	3.2	8.00	72.6	7.35	1.42
AL844	4 × 4			29.4				145	13.2	2.88
AL866	6 × 6			43.0				218	15.4	4.23
AL1022	2 × 2	31.75	9.53	19.6	24.5	4.0	9.59	108	11.6	2.46
AL1044	4 × 4			36.2				216	20.6	4.81
AL1066	6 × 6			53.5				324	24.0	7.24
AL1222	2 × 2	38.10	11.10	24.0	29.2	4.8	11.22	152	16.5	3.35
AL1244	4 × 4			43.7				304	29.1	6.58
AL1266	6 × 6			63.4				456	34.2	9.82
AL1422	2 × 2	44.45	12.70	27.8	34.2	5.6	12.82	205	22.1	4.99
AL1444	4 × 4			51.2				410	38.9	9.56
AL1466	6 × 6			73.6				615	46.1	14.13
AL1622	2 × 2	50.80	14.28	31.8	40.3	6.4	14.47	269	28.3	6.35
AL1644	4 × 4			58.4				539	49.9	12.62
AL1666	6 × 6			84.8				809	58.8	18.87

SY Chain No.	Lacing	Dimensions - mm						Average Ultimate Strength	Maximum Allowable Load	Average Weight
		Pitch	Pin		Plate		Hole Dia			
			Dia.	Length	Height	Thickness				
			P	D	L	H				
							kN	kN	kg/m	
BL422	2 × 2	12.70	5.08	10.5	11.7	2.0	5.15	27.5	4.51	0.64
BL423	2 × 3			12.5				0.79		
BL434	3 × 4			16.8				1.07		
BL444	4 × 4			19.0				1.22		
BL446	4 × 6			23.0				1.58		
BL466	6 × 6			27.5				1.89		
BL522	2 × 2	15.875	5.95	12.4	14.6	2.4	6.04	42.7	6.86	1.01
BL523	2 × 3			15.0				1.19		
BL534	3 × 4			20.0				1.61		
BL544	4 × 4			22.2				1.80		
BL546	4 × 6			27.6				2.26		
BL566	6 × 6			32.4				2.65		
BL622	2 × 2	19.05	7.93	16.6	17.5	3.2	8.00	70.6	9.81	1.53
BL623	2 × 3			19.5				1.89		
BL634	3 × 4			26.2				2.68		
BL644	4 × 4			29.2				3.04		
BL646	4 × 6			36.5				4.15		
BL666	6 × 6			43.0				4.58		
BL822	2 × 2	25.40	9.53	19.6	24.1	4.0	9.59	114	17.0	2.57
BL823	2 × 3			23.8				3.17		
BL834	3 × 4			32.5				4.37		
BL844	4 × 4			36.2				4.95		
BL846	4 × 6			45.0				6.23		
BL866	6 × 6			53.5				7.44		
BL1022	2 × 2	31.75	11.10	24.0	29.3	4.8	11.20	157	26.0	3.73
BL1023	2 × 3			28.6				4.64		
BL1034	3 × 4			38.7				6.50		
BL1044	4 × 4			43.7				7.41		
BL1046	4 × 6			53.4				9.21		
BL1066	6 × 6			63.4				11.07		
BL1222	2 × 2	38.10	12.70	27.8	35.1	5.6	12.82	207	36.8	4.77
BL1223	2 × 3			34.2				6.46		
BL1234	3 × 4			45.5				9.05		
BL1244	4 × 4			51.2				10.27		
BL1246	4 × 6			62.6				11.86		
BL1266	6 × 6			73.6				14.40		
BL1422	2 × 2	44.45	14.28	31.8	40.9	6.4	14.39	270	49.0	7.87
BL1423	2 × 3			38.8				8.90		
BL1434	3 × 4			51.7				11.61		
BL1444	4 × 4			58.4				12.87		
BL1446	4 × 6			71.2				17.86		
BL1466	6 × 6			84.8				22.33		
BL1622	2 × 2	50.80	17.45	35.8	46.7	7.2	17.62	392	58.8	9.77
BL1623	2 × 3			43.7				12.08		
BL1634	3 × 4			58.9				16.85		
BL1644	4 × 4			65.9				18.85		
BL1646	4 × 6			80.2				23.94		
BL1666	6 × 6			96.2				28.54		

Leaf Chains

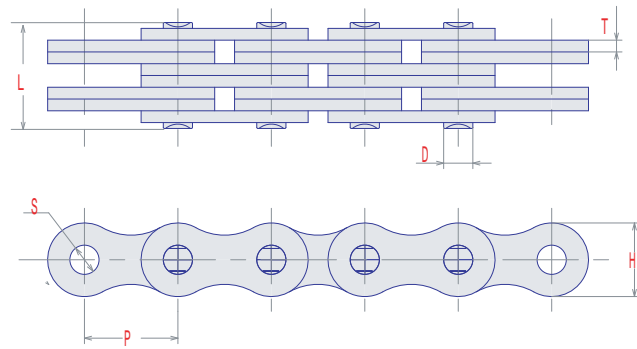
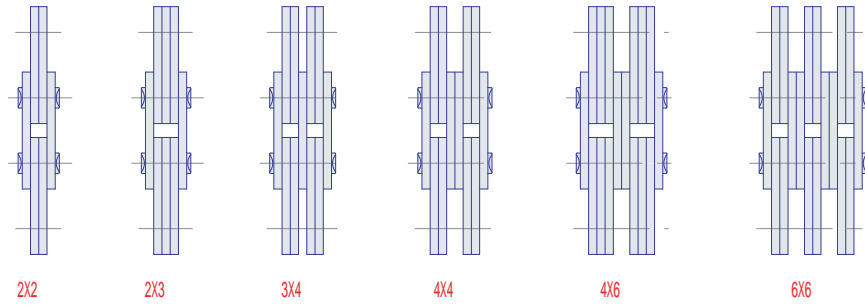

SY Chain No.	Lacing	Dimensions - mm						Minimum Ultimate Strength	Average Chain Weight
		Pitch	Pin		Plate		Hole Dia		
			Dia.	Length	Height	Thickness			
P	D	L	H	T	S	kN	kg/m		
LL0822	2 x 2	12.70	4.45	7.6	10.9	1.25	4.46	17.8	0.31
LL0844	4 x 4			13.0				31.1	0.60
LL0866	6 x 6			18.4				44.5	0.89
LL1022	2 x 2	15.875	5.08	9.3	13.7	1.65	5.09	22.2	0.48
LL1044	4 x 4			16.1				44.5	0.94
LL1066	6 x 6			22.9				66.7	1.40
LL1222	2 x 2	19.05	5.72	10.7	16.1	1.80	5.73	28.9	0.63
LL1244	4 x 4			18.5				57.8	1.22
LL1266	6 x 6			26.3				86.7	1.82
LL1622	2 x 2	25.40	8.28	50.1	21.0	3.20	8.30	58.0	1.48
LL1644	4 x 4			30.2				116	2.90
LL1666	6 x 6			43.2				174	4.31
LL2022	2 x 2	31.75	10.19	20.1	26.4	3.50	10.21	95.0	2.17
LL2044	4 x 4			35.1				190	4.24
LL2066	6 x 6			50.1				285	6.30
LL2422	2 x 2	38.10	14.63	28.4	33.4	4.90	14.65	170	4.02
LL2444	4 x 4			49.4				340	7.79
LL2466	6 x 6			70.4				510	11.55
LL2822	2 x 2	44.45	15.90	34.0	37.0	6.3	15.92	200	5.42
LL2844	4 x 4			60.0				400	10.56
LL2866	6 x 6			86.0				600	15.71
LL3222	2 x 2	50.80	17.81	35.0	42.2	6.3	17.83	260	5.92
LL3244	4 x 4			61.0				520	11.50
LL3266	6 x 6			87.0				780	17.06

LEAF CHAINS

SELECTION OF LEAF CHAIN

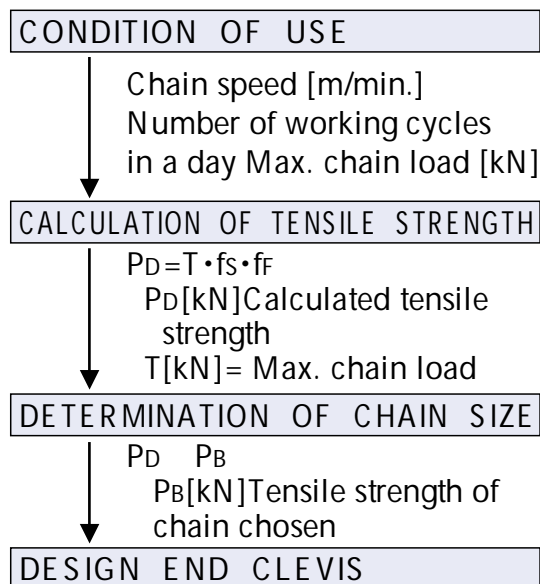

f_s : SERVICE FACTOR

Type of load	Example of use	f_s	Suitable Chain size
Smooth load	Smooth starts & stops and slow and gentle load variations.	1.0	AL series LL series
Smooth shocks	Frequent starts & stops load variations and reverse motions.	1.3	AL series LL series BL series
Heavy shocks	Sudden starts & stops, load variations and reverse motions.	1.5	BL series

f_f : SAFETY FACTOR

Type of load	No. of reciprocating max./day	f_f	Chain speed
AL LL	10 100	9 12	max. 30m/min
BL	1000	9	

DIMENSION OF ANCHOR CLEVIS

Lacing	$G = 2(T_{max.} + 4CL + 0.008P)$
2 x 2	$G = 3(T_{max.} + 5CL + 0.008P)$
2 x 3	$A = K + G$
3 x 4	$K = 3(T_{max.} + CL)$ $G = K - (T_{max.} + 0.004P)$
4 x 4	$A = K + G$
6 x 6	$K = 4(T_{max.} + CL)$ $G = K - 2(T_{max.} + 0.004P)$
4 x 6	$A = K + G$ $K = 5(T_{max.} + CL)$ $G = K - 2(T_{max.} + 0.004P)$
8 x 8	$A = K + G$ $K = 4(T_{max.} + CL)$ $G = K - 2(T_{max.} - 0.004P)$

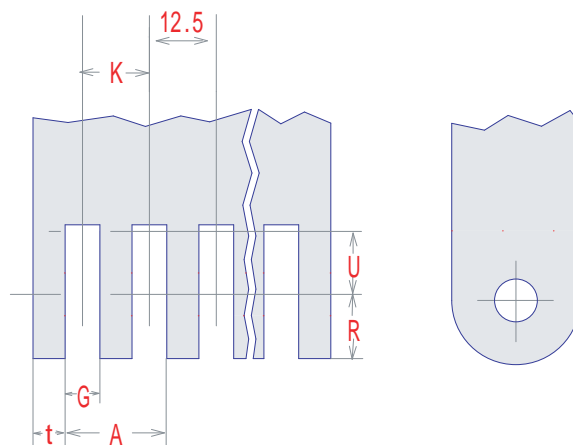

- P = chain pitch
- $T_{max.}$ = maximum link plate thickness
- R = end of radius = 0.5P
- t = minimum thickness of outside flange = $T_{max.}$
- U = minimum depth of slot for clearance = 0.5P
- CL = clearance
= 0.038 for 15.875 pitch and smaller
0.051 for 19.05 pitch or larger

GENERAL CLEVIS PROPORTIONS

STANDARD ATTACHMENT



A-1 attachment

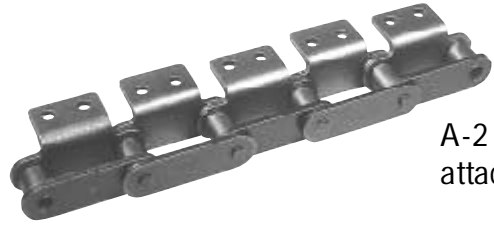

A-2 attachment

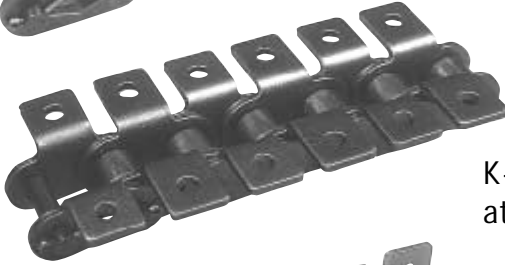

K-1 attachment

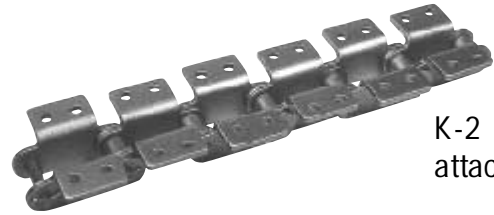

K-2 attachment

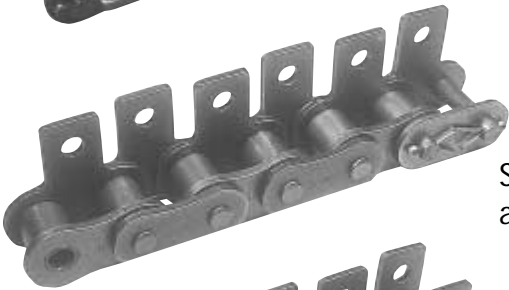

SA-1 attachment



SA-2 attachment

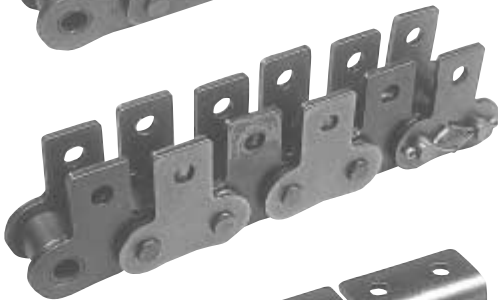

SK-1 attachment

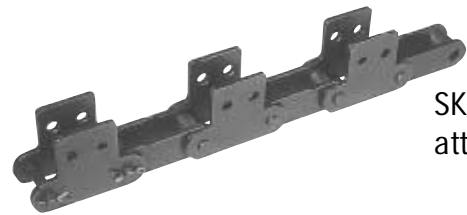

SK-2 attachment

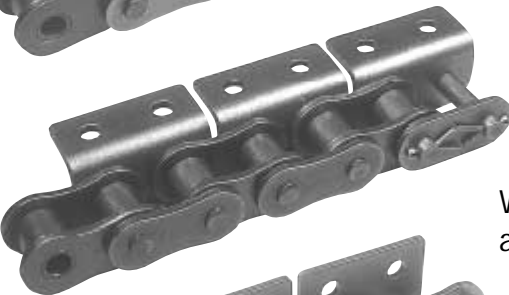

WA-2 attachment



GK-1 attachment

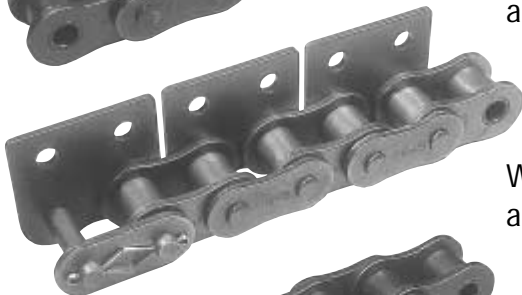

WSA-2 attachment



D-1 attachment



D-1 attachment



D-3 attachment



D-3 attachment

SPECIAL ATTACHMENT

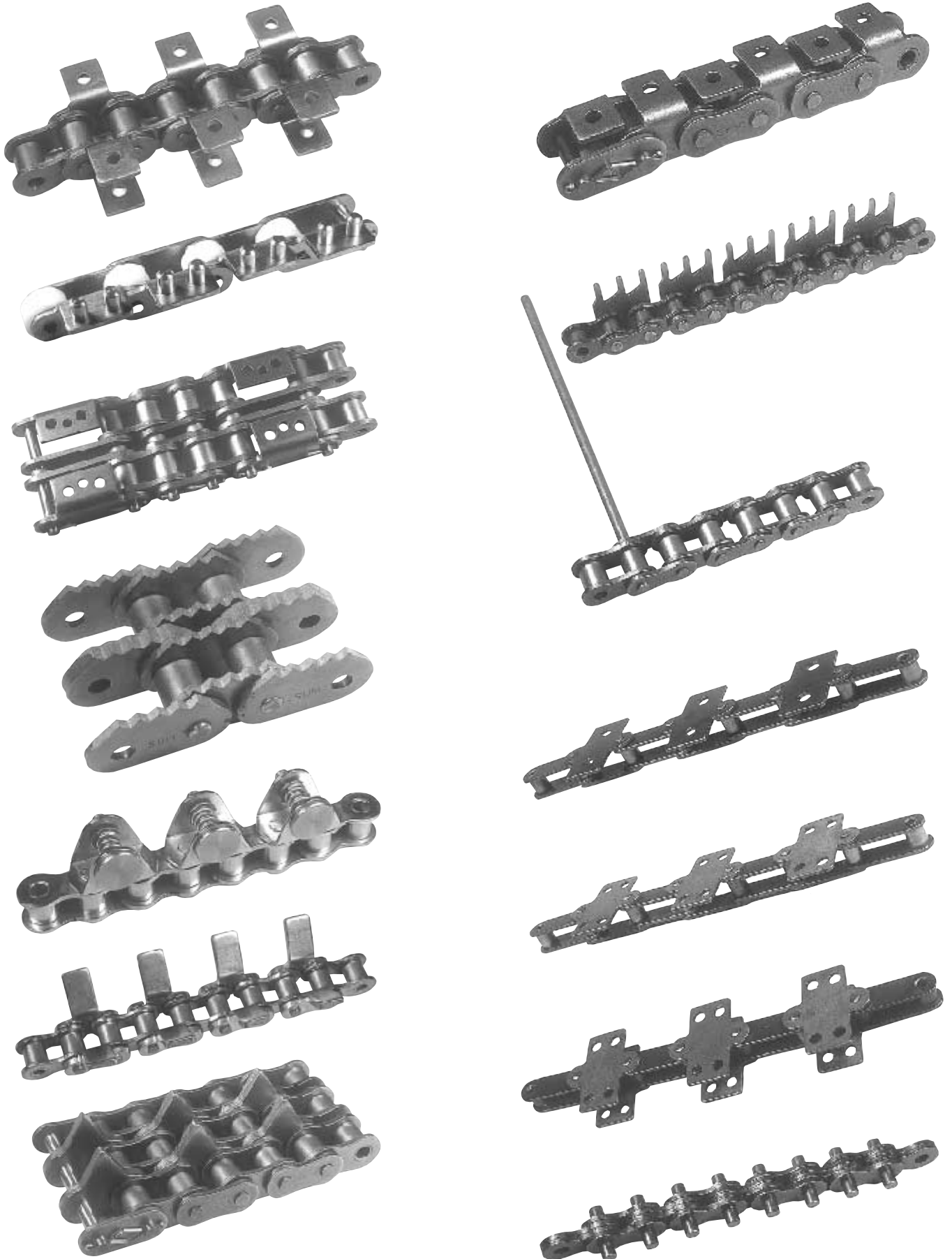

BS Standard Attachment Chains

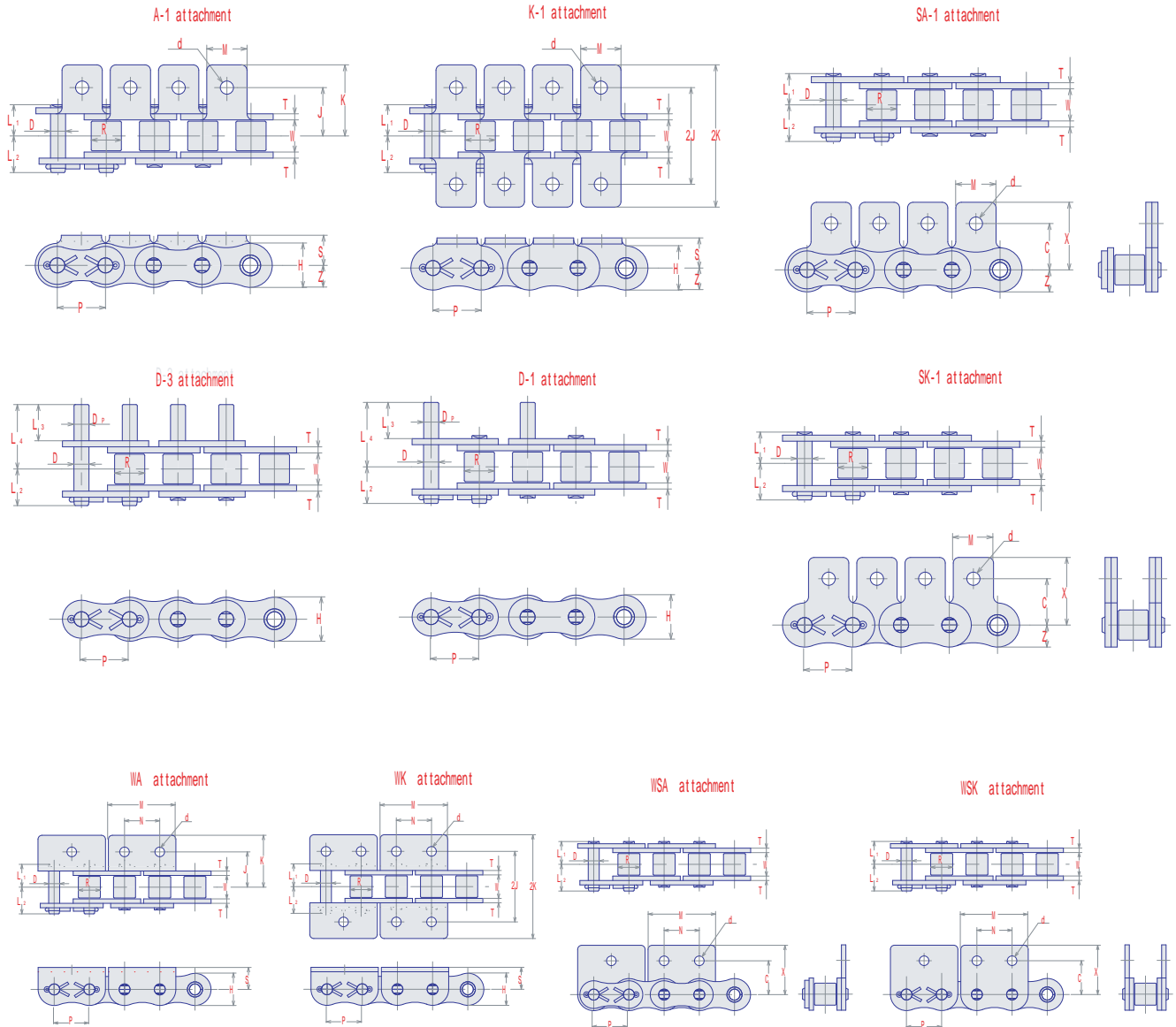

SY Chain No. (BS)	Pitch P	Dimensions - mm											Minimum Ultimate Strength kN	Maximum Allowable Load kN	Average Chain Weight kg/m
		Roller		Pin				Plate		Trans. Pitch TP					
		Width W	Dia. R	Dia. D	Length			Height H	Thickness						
				LR	LC	L1	L2		T1	T2					
08B	12.70	7.75	8.51	4.45	16.7	18.0	8.4	9.6	11.8	1.5	1.5	13.92	17.8	3.14	0.61
10B	15.88	9.65	10.16	5.08	19.0	20.7	9.5	11.2	14.7	1.65	1.65	16.59	22.3	4.90	0.89
12B	19.05	11.68	12.07	5.72	22.0	23.6	11.0	12.6	16.1	1.8	1.8	19.46	28.9	7.06	1.14
16B	25.40	17.02	15.88	8.26	35.1	38.2	17.6	20.6	21.0	3.2	4.0	31.88	60.8	12.6	2.59
20B	31.75	19.56	19.05	10.16	40.2	44.0	20.1	23.9	26.4	3.5	4.7	36.45	95.1	19.6	3.76

A-1, K-1 ATTACHMENT

SY Chain No.	Common Dimensions			Original Dimensions				Additional Weight	
	M	d	S	A-1		K-1		A-1	K-1
				J	K	2J	2K	g/pc	
08B	11.0	4.3	8.5	13.8	20.9	27.6	41.8	2.0	4.0
10B	14.0	5.3	10.5	15.8	24.2	31.6	48.4	3.2	6.4
12B	18.0	6.4	12.2	17.6	27.3	35.2	54.6	4.5	9.0
16B	24.0	8.4	17.0	29.0	41.9	58.0	83.8	20	40
20B	30.0	10.5	21.0	34.5	49.3	69.0	98.6	25	50

SA-1,SK-1 ATTACHMENT

SY Chain No.	Common Dimensions					Additional Weight	
	M	d	C	X	Z	SA-1	SK-1
						g/pc	
08B	11.0	4.3	13.7	20.8	5.9	2.0	4.0
10B	14.0	5.3	16.5	24.9	7.4	3.2	6.4
12B	18.0	6.4	18.5	28.1	8.1	4.5	9.0
16B	24.0	8.4	27.4	40.0	10.3	20	40
20B	30.0	10.5	33.0	47.5	13.2	25	50

D-1,D-3 ATTACHMENT

SY Chain No.	Common Dimensions				Additional Weight	
	Dp	L3	L4	H	D-1	D-3
					g/pc	
08B	4.45	14.8	21.8	11.8	1.8	3.6
10B	5.08	17.6	25.9	14.7	2.8	5.6
12B	5.72	20.7	30.5	16.1	4.1	8.2
16B	8.28	33.3	49.3	20.6	14.0	28.0
20B	10.16	38.3	56.6	26.4	24.3	48.6

WA-2,WK-2,WSA-2,WSK-2 ATTACHMENT

SY Chain No.	Common Dimensions				Original Dimensions					
	M	d	N	S	WA		WK		WSA, WSK	
					J	K	2J	2K	C	X
08B	24.5	4.3	12.7	8.5	13.8	20.9	27.6	41.8	13.7	20.8
10B	30.6	5.3	15.9	10.5	15.8	24.2	31.6	48.4	16.5	24.9
12B	35.2	6.4	19.1	12.2	17.6	27.3	35.2	54.6	18.5	28.1
16B	46.4	8.4	25.4	17.0	29.0	41.9	58.0	83.8	27.4	40.0
20B	58.2	10.5	31.8	21.0	34.5	49.3	69.0	98.6	33.0	47.5

ANSI Standard Attachment Chains

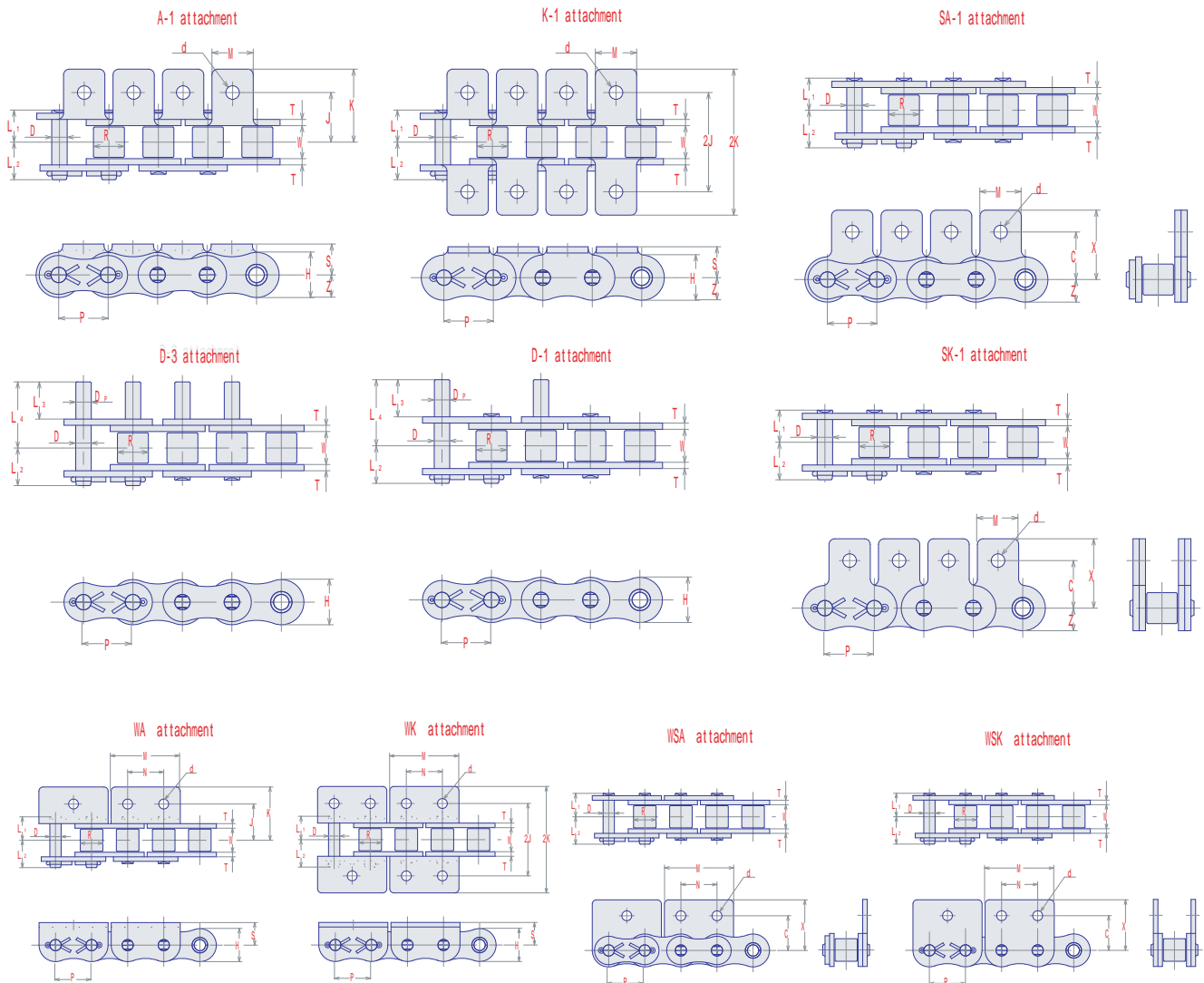

BASIC SPECS FOR ASSEMBLING ATTACHMENT

SY Chain No. (ANSI)	Dimensions - mm								Average Ultimate Strength kN	Average Chain Weight kg/m
	Pitch P	Roller		Pin		Plate				
		Width W	Dia. R	Dia. D	Length	Height H	Thick. T			
					L1	L2				
SY 35	9.525	4.78	*5.08	3.58	5.9	6.8	9.0	1.25	10.8	0.34
SY 40	12.70	7.95	7.92	3.96	8.2	9.1	11.7	1.5	19.1	0.60
SY 50	15.875	9.53	10.16	5.08	10.3	11.6	14.6	2.0	31.9	0.98
SY 60	19.05	12.70	11.91	5.95	12.7	13.9	17.5	2.4	43.1	1.46
SY 80	25.40	15.88	15.88	7.93	16.2	18.8	23.4	3.2	78.5	2.52
SY 100	31.75	19.05	19.05	9.53	19.6	23.2	29.3	4.0	118	3.91
SY 120	38.10	25.40	22.23	11.10	24.7	28.5	35.1	4.8	167	5.76
SY 140	44.45	25.40	25.4	12.70	26.9	31.2	40.9	5.6	216	7.41
SY 160	50.80	31.75	28.58	14.28	32.1	36.4	46.7	6.4	275	9.79

A-1, K-1 ATTACHMENT

SY Chain No.	Common Dimensions				Original Dimensions				Additional Weight	
	M	d	S	Z	A-1		K-1		A-1	K-1
					J	K	2J	2K	g/pc	
SY35	7.9	3.4	6.4	4.5	9.5	14.3	19.1	28.6	0.9	1.8
SY40	9.5	3.6	7.9	5.8	12.7	17.3	25.4	34.6	1.2	2.4
SY50	12.7	5.2	10.3	7.3	15.9	23.3	31.8	46.6	4	8
SY60	15.9	5.2	11.9	8.7	19.1	28.1	38.1	56.2	6.5	13
SY80	19.1	6.8	15.9	11.7	25.4	35.9	50.8	71.8	13	26
SY100	25.4	8.8	19.8	14.6	31.8	44.3	63.6	88.6	27	54
SY120	28.6	10.5	23.0	17.5	38.1	54.7	76.2	109.4	47	94
SY140	34.7	12.0	28.6	20.4	44.5	63.2	89.0	126.4	65	130
SY160	38.1	14.0	31.8	23.3	50.8	71.9	101.6	143.8	88	176

SA-1,SK-1 ATTACHMENT

SY Chain No.	Common Dimensions				Z	Additional Weight	
	M	d	C	X		SA-1	SK-1
						g/pc	
SY35	7.9	3.4	9.5	14.5	4.5	0.9	1.8
SY40	9.5	3.6	12.7	18.5	5.8	1.2	2.4
SY50	12.7	5.2	15.9	23.0	7.3	4	8
SY60	15.9	5.2	18.3	26.7	8.7	6.5	13
SY80	19.1	6.8	24.6	34.5	11.7	13	26
SY100	25.4	8.8	31.8	43.0	14.6	27	54
SY120	28.6	10.5	36.6	51.4	17.5	47	94
SY140	34.7	12.0	44.4	63.1	20.4	65	130
SY160	38.1	14.0	50.8	69.5	23.3	88	176

D-1,D-3 ATTACHMENT

SY Chain No.	Common Dimensions				Additional Weight	
	Dp	L3	L4	H	D-1	D-3
					g/pc	
SY35	3.58	9.5	14.7	9	0.8	1.6
SY40	3.96	9.5	16.8	11.7	1	2
SY50	5.08	11.9	21.0	14.6	2	4
SY60	5.95	14.3	25.9	17.5	3	6
SY80	7.93	19.1	33.9	23.4	7	14
SY100	9.53	23.8	41.9	29.3	12	24
SY120	11.10	28.6	51.4	35.1	20	40
SY140	12.70	33.3	57.5	40.9	30	60
SY160	14.28	38.1	67.4	46.7	45	90

WA-1,WA-2,WK-1,WK-2,WSA-1,WSA-2,WSK-1,WSK-2 ATTACHMENT

SY Chain No.	Common Dimensions				Original Dimensions					
	M	d	N	S	WA		WK		WSA, WSK	
					J	K	2J	2K	C	X
SY40	24.3	3.6	12.7	7.9	12.7	17.3	25.4	34.6	12.7	17.3
SY50	30.4	5.2	15.9	10.3	15.9	23.3	31.8	46.6	15.9	23.1
SY60	37.0	5.2	19.1	11.9	19.1	28.1	38.1	56.2	18.3	27.1
SY80	48.6	6.8	25.4	15.9	25.4	35.9	50.8	71.8	24.6	34.5
SY100	61.0	8.8	31.8	19.8	31.8	44.3	63.6	88.6	31.8	43.0

DOUBLE PITCH ATTACHMENT CHAINS

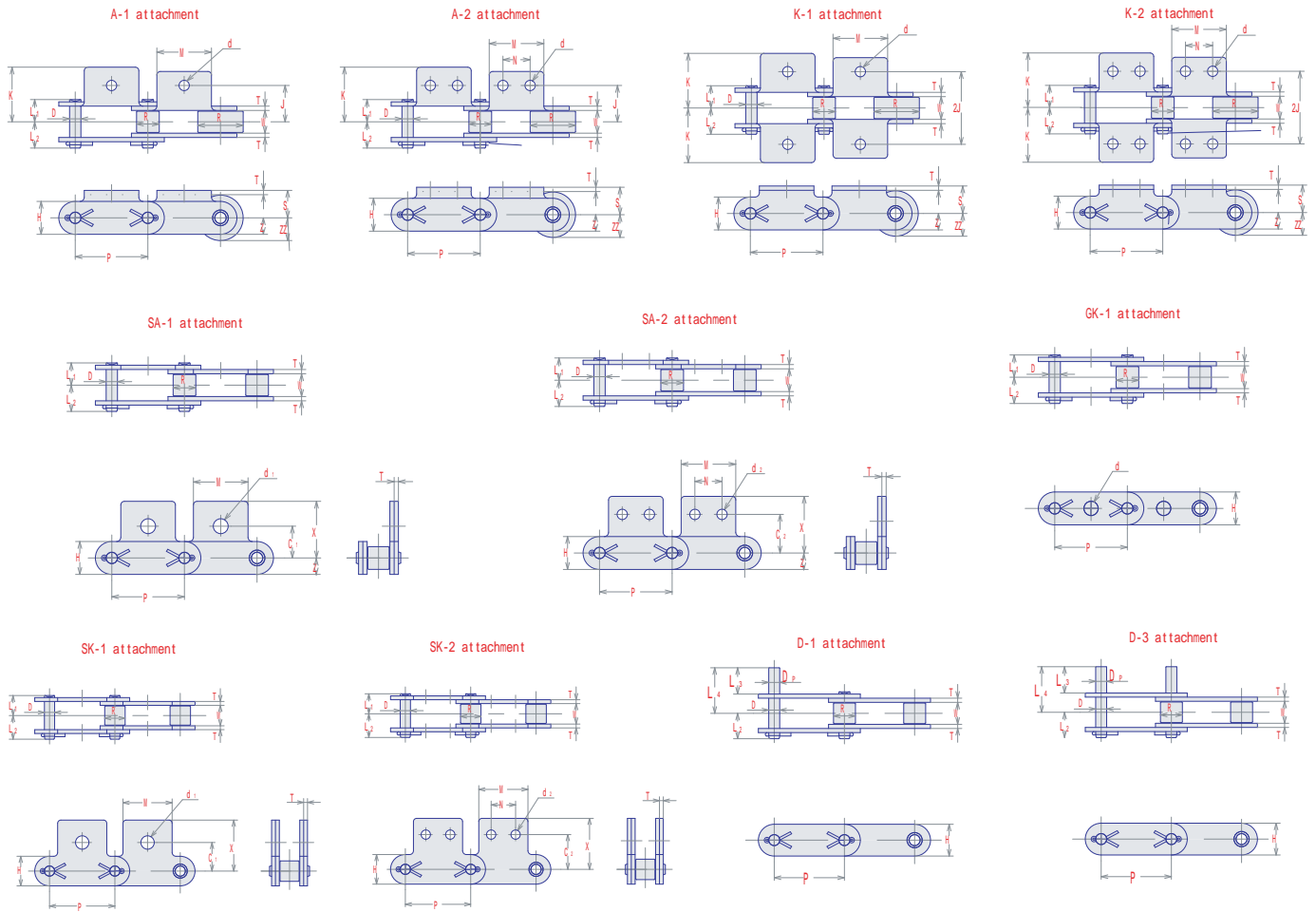

BASIC SPECS FOR ASSEMBLING ATTACHMENT

SY Chain No. (ANSI)	Dimensions - mm								Average Ultimate Strength kN	Average Chain Weight kg/m
	Pitch P	Roller		Pin		Plate				
		Width W	Dia. R	Dia. D	Length L1	Length L2	Height H	Thick. T		
C2040	25.40	7.95	7.92	3.96	8.2	9.1	11.4	1.5	19.1	0.48
C2042			15.88							0.82
C2050	31.75	9.53	10.16	5.08	10.3	11.6	15.0	2.0	31.9	0.82
C2052			19.05							1.26
C2060H	38.10	12.70	11.91	5.95	14.4	16.7	17.0	3.2	54.9	1.38
C2062H			22.23							2.08
C2080H	50.80	15.88	15.88	7.93	17.8	21.1	22.6	4.0	90.2	2.32
C2082H			28.58							3.36
C2100H	63.50	19.05	19.05	9.53	21.1	24.6	28.6	4.8	137	3.46
C2102H			39.67							5.64
C2120H	76.20	25.40	22.23	11.10	26.3	30.7	34.9	5.6	186	4.92
C2122H			44.45							7.87
C2160H	101.60	31.75	28.58	14.28	28.5	33.1	47.6	7.2	306	8.02
C2162H			57.15							12.77

A-1,A-2,K-1,K-2, ATTACHMENT

SY Chain No.		Dimensions - mm								
Standard Roller	Carrier Roller	M	d	N	S	Z	ZZ	A-1, A-2		K-1, K-2
								J	K	2J
C2040	C2042	19.1	3.6	9.5	9.1	5.7	- 7.94	12.7	19.1	25.4
C2050	C2052	23.8	5.2	11.9	11.1	7.5	- 9.53	15.9	24.2	31.8
C2060H	C2062H	28.6	5.2	14.3	14.7	8.5	- 11.11	21.4	31.2	42.8
C2080H	C2082H	38.1	6.8	19.1	19.1	11.3	- 14.29	27.8	40.6	55.6
C2100H	C2102H	47.6	8.8	23.8	23.4	14.3	- 19.84	33.3	50.0	66.6
C2120H	C2122H	57.2	10.5	28.6	27.8	17.4	- 22.22	39.7	61.9	79.4
C2160H	C2162H	76.2	14.0	38.1	36.5	23.8	- 28.58	52.4	76.1	104.8

SA-1,SA-2,SK-1,SK-2 ATTACHMENT

SY Chain No.		Dimensions - mm								
Standard Roller	Carrier Roller	M	X	Z	ZZ	SA-1, SK-1		SA-2, SK-2		
						C1	d1	C2	d2	N
C2040	C2042	19.1	19.8	5.7	- 7.94	11.1	5.2	13.5	3.6	9.5
C2050	C2052	23.8	24.6	7.5	- 9.53	14.3	6.8	15.9	5.2	11.9
C2060H	C2062H	28.6	30.6	8.5	- 11.11	17.5	8.8	19.1	5.2	14.3
C2080H	C2082H	38.1	40.2	11.3	- 14.29	22.2	10.5	25.4	6.8	19.1
C2100H	C2102H	47.6	50.3	14.3	- 19.84	28.6	14.0	31.8	8.8	23.8
C2120H	C2122H	57.2	61.1	17.4	- 22.22	33.3	16.0	37.3	10.5	28.6
C2160H	C2162H	76.2	76.2	23.8	- 28.58	44.5	21.0	50.8	14.0	38.1

D-1,D-3,GK-1 ATTACHMENT

SY Chain No.		Dimensions - mm								Additional Weight		
Standard Roller	Carrier Roller	D-1, D-3			GK-1					D-1	D-3	
		Dp	L3	L4	d					g/pc		
C2040	C2042	3.96	9.5	16.8	4.1					0.9	1.8	
C2050	C2052	5.08	11.9	21.1	5.1	5.2	6.2	6.4	8.0	8.2	1.8	3.6
C2060H	C2062H	5.95	14.3	27.5	6.05	6.4	7.2	8.1			3.0	6
C2080H	C2082H	7.93	19.1	35.6	8.0	8.1					7	14
C2100H	C2102H	9.53	23.8	43.2	10.1					12	24	
C2120H	C2122H	11.10	28.6	53.0	12.1					20	40	
C2160H	C2162H	14.28	38.1	69.0	-					44	88	

To be added to chain weight for each attachment used.

SIDE ROLLER CHAINS

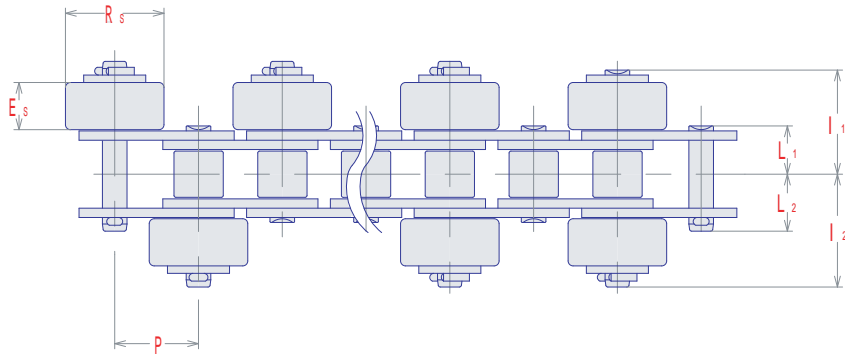

SY Chain No.	Dimensions - mm							Average Chain Weight kg/m	
	Pitch P	Side roller			Chain Pin		Riveted Side L1		Cotter Side L2
		Dia.	Width	Pin-Length					
		Rs	Es	l1	l2				
SY-40	12.70	15.88	7.6	17.3	19.1	8.2	10.3	0.86	
SY-50	15.875	19.05	9.2	21.4	23.1	10.3	11.6	1.40	
SY-60	19.05	22.23	12.5	27.9	30.0	12.7	14.9	1.93	
SY-80	25.40	28.58	15.6	34.8	37.8	16.2	18.8	3.30	
SY-100	31.75	39.67	18.5	41.9	45.5	19.6	23.2	3.57	
C 2040	25.40	15.88	7.6	17.3	19.1	8.2	10.3	0.61	
C 2050	31.75	19.05	9.2	21.4	23.1	10.3	11.6	1.01	
C 2060H	38.10	22.23	12.5	29.5	31.6	14.4	16.7	1.65	
C 2080H	50.80	28.58	15.6	36.5	39.5	17.8	21.1	2.74	
C 2100H	63.50	39.67	18.5	43.4	47.0	21.1	24.6	4.15	
C 2042	25.40	23.00	7.6	17.3	19.1	8.2	10.3	1.20	
C 2052	31.75	27.00	9.2	21.4	23.1	10.3	11.6	1.65	
C 2062H	38.10	30.00	12.5	29.5	31.6	14.4	16.7	2.60	

Average weight shows chains with plastic side rollers every second pitches on both sides.

SPECIAL AA-1 ATTACHMENT CHAINS

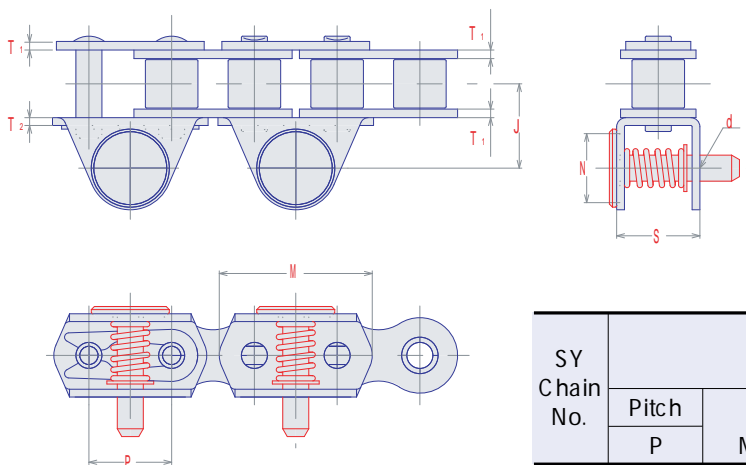

SY Chain No.	Dimensions - mm						Plate	
	Pitch P	M	N	J	S	d	Thickness	
							T1	T2
08B	12.70	23.5	12.9	15.3	16.0	5.15	1.5	1.5
10B	15.875	29.4	12.9	16.2	16.0	5.15	1.65	1.5

TOP ROLLER CHAINS

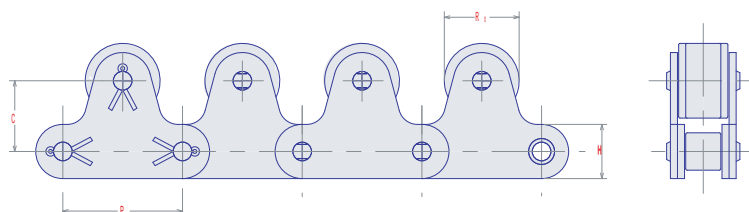
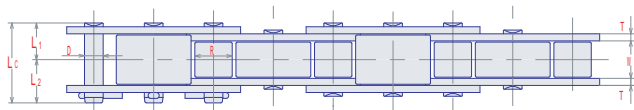

Top Roller Dia. Only Every Link

SY-40	11.00
SY-50	15.00
SY-60	18.00
SY-80	24.00
SY-100	30.00

SY Chain No.	Dimensions - mm										Average Ultimate Strength kN	Average Chain Weight kg/m
	Pitch P	Roller		Pin			Plate		Top-Roller			
		W	Dia. R	Dia. D	Length L1 L2		Height H	Thickness T	Position C	Dia. Rt		
SY-40	12.70	7.95	7.92	3.96	8.2	9.1	11.7	1.5	12.7	15.88	19.1	1.10
SY-50	15.875	9.53	10.16	5.08	10.3	11.6	14.6	2.0	15.9	19.05	31.9	1.61
SY-60	19.05	12.70	11.91	5.95	12.7	13.9	17.5	2.4	18.3	22.23	43.1	2.80
SY-80	25.40	15.88	15.88	7.93	16.2	18.8	23.4	3.2	24.6	28.58	78.5	4.60
SY-100	31.75	19.05	19.05	9.53	19.6	23.2	29.3	4.0	31.8	39.67	118	7.60
C2040	25.40	7.95	7.92	3.96	8.2	10.3	11.4	1.5	15.0	15.88	19.1	1.29
C2050	31.75	9.53	10.16	5.08	10.3	11.6	15.0	2.0	19.0	19.05	31.9	1.99
C2060H	38.10	12.70	11.91	5.95	14.4	16.7	17.0	3.2	23.0	22.23	54.9	3.50
C2080H	50.80	15.88	15.88	7.93	17.8	21.1	22.6	4.0	29.0	28.58	90.2	5.30
C2100H	63.50	19.05	19.05	9.53	21.1	24.6	28.6	4.8	35.4	39.67	137	8.60
C2042	25.40	7.95	15.88	3.96	8.2	10.3	11.4	1.5	15.0	15.88	19.1	1.61
C2052	31.75	9.53	19.05	5.08	10.3	11.6	15.0	2.0	19.0	19.05	31.9	2.50
C2062H	38.10	12.70	22.23	5.95	14.4	16.7	17.0	3.2	23.0	22.23	54.9	4.30
C2082H	50.80	15.88	28.58	7.93	17.8	21.1	22.6	4.0	29.0	28.58	90.2	6.50
C2102H	63.50	19.05	39.67	9.53	21.1	24.6	28.6	4.8	35.4	39.67	137	10.70

Average weight shows chains with top rollers spaced every second.

In case of large roller chain, the sprocket becomes special type of small out side diameter.

(If cannot be use the sprocket of double pitch chain.)

BOOK BINDING CHAIN

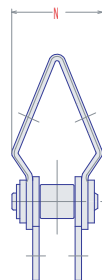
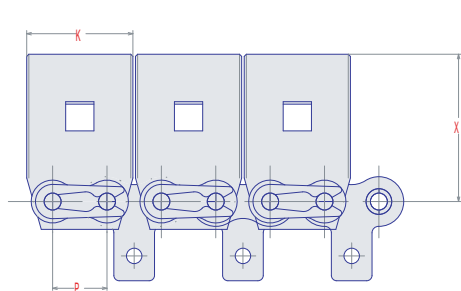

SY Chain No.	Dimensions - mm				Average Ultimate Strength kN	Average Chain Weight kg/m
	Pitch P	X	K	N		
	40 Binding Chain	12.70	34.4	24.8	21.8	19.1

81X SERIES

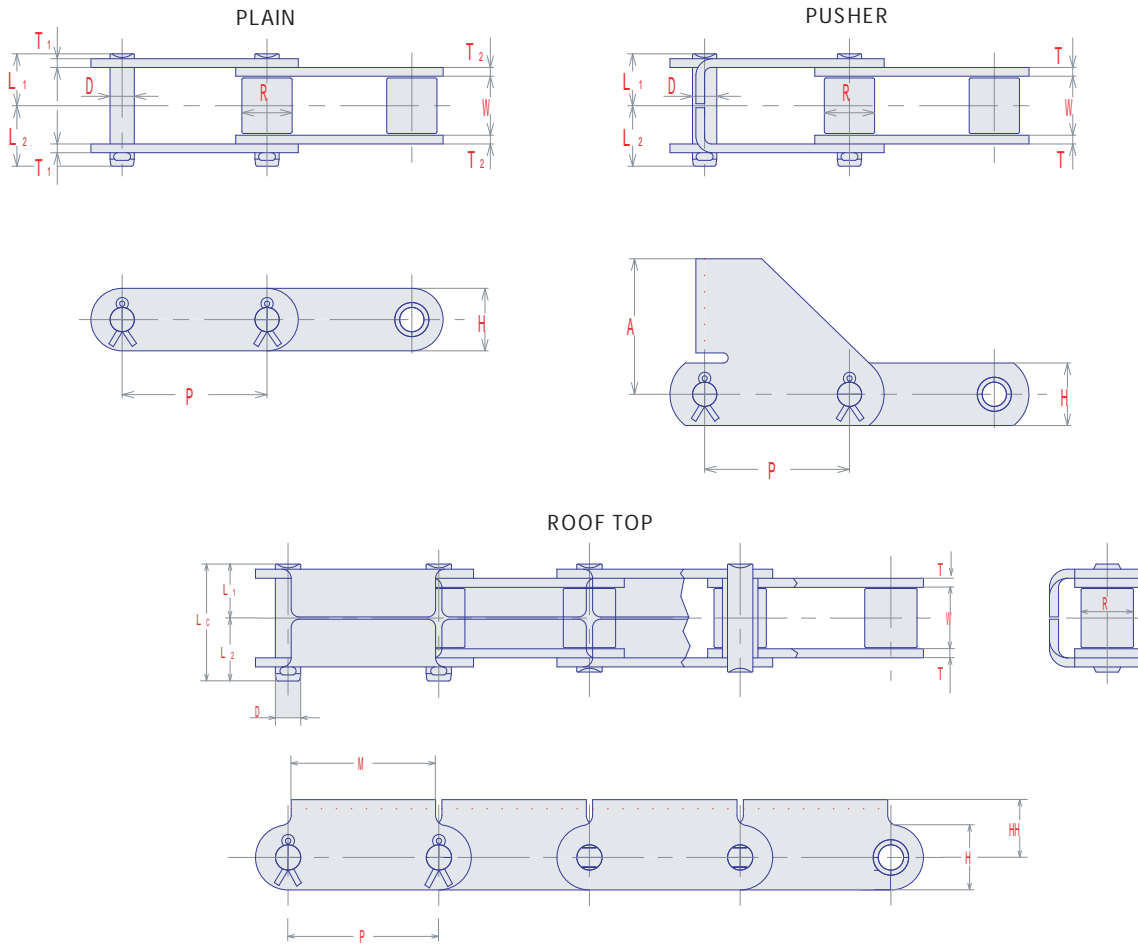

81X . 81XH. 81XH-S

SY Chain No.	Dimensions - mm									Average Ultimate Strength	Approx. Weight
	Pitch	Roller		Pin		Plate					
		Width	Dia.	Dia.	Length	Height	Thickness				
P	W	R	D	L1	L2	H	T1	T2	kN	kg/m	
81X	66.27	27.0	23.0	11.1	24.0	28.4	28.6	3.9	3.9	110	3.9
81XH	66.27	27.0	23.0	11.1	30.2	34.1	32.1	5.5	8.0	187	5.8
81XH-S	66.27	27.0	23.0	11.1	32.0	36.3	32.1	8.0	8.0	187	6.8

81X PUSHER

SY Chain No.	Dimensions - mm									Average Ultimate Strength
	Pitch	Roller		Pin		Plate				
		Width	Dia.	Dia.	Length	Height	Thickness			
P	W	R	D	L1	L2	H	A	T	kN	
81X Pusher	66.27	27.0	23.0	11.1	24.0	28.4	28.6	65.1	3.9	110

81X ROOF TOP CHAIN

SY Chain No.	Dimensions - mm										Average Ultimate Strength	Approx. Weight
	Pitch	Roller		Pin		Plate		Roof Width	Roof Height			
		Width	Dia.	Dia.	Length	Height	Thick					
P	W	R	D	L1	L2	H	T	M	HH	kN	kg/m	
81X Roof Top Chain	66.27	27.0	23.0	11.1	24.0	28.4	28.6	3.9	63.5	31.8	110	5.5

3939 ATTACHMENT CHAIN

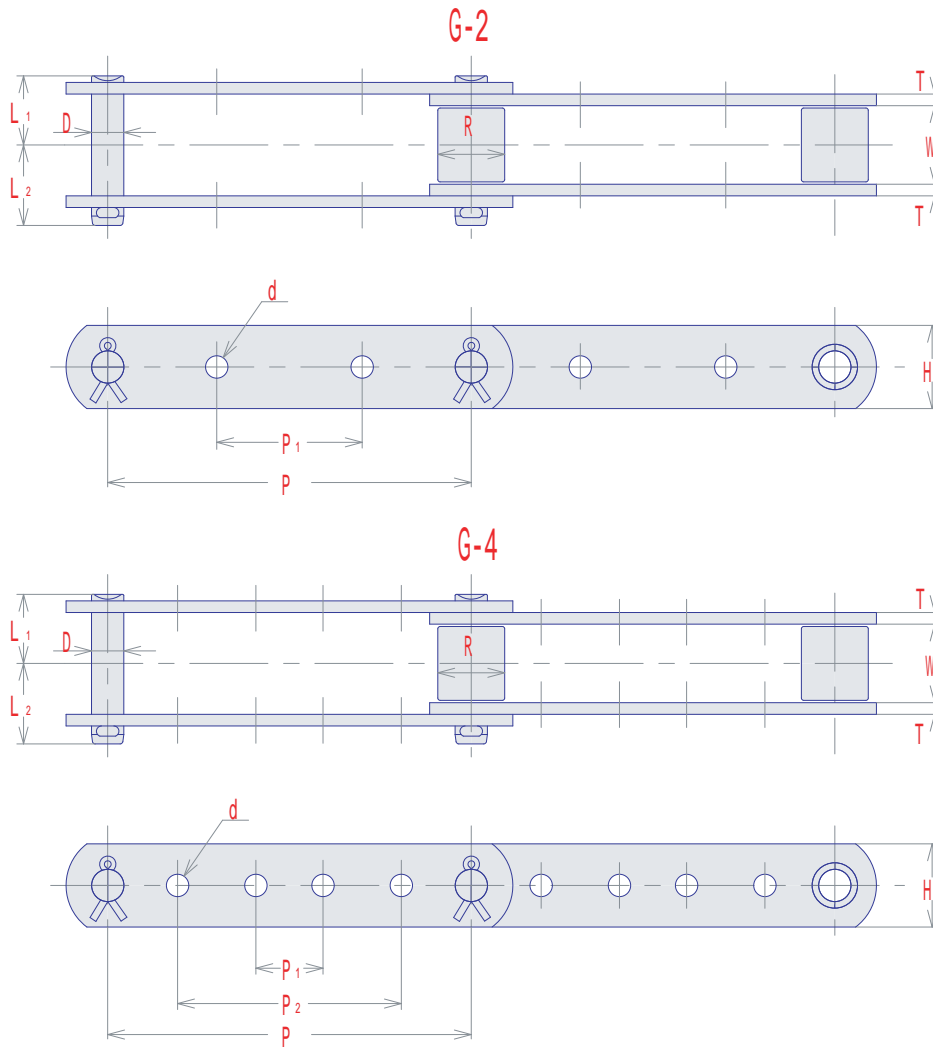

3939 G-2 ATTACHMENT

SY Chain No.	Dimensions - mm										Average Ultimate Strength kN
	Pitch P	Roller		Pin		Plate		G-2		Hole d	
		Width W	Dia. R	Dia. D	Length L1 L2	Height H	Thick T	Pitch P1			
3939	203.20	27.0	23.0	11.1	24.0	28.4	28.6	3.9	38.1 76.2 92.1 101.6	7.2	110

3939 G-4 ATTACHMENT

SY Chain No.	Dimensions - mm										Average Ultimate Strength kN	
	Pitch P	Roller		Pin		Plate		G-4		Hole d		
		Width W	Dia. R	Dia. D	Length L1 L2	Height H	Thick T	Pitch P1 P2				
3939	203.20	27.0	23.0	11.1	24.0	28.4	28.6	3.9	38.1 38.1 38.1	76.2 92.1 101.6	7.2	110

Trouble Shooting Hints

The below chart shows the most common chain failures and causes, but not necessarily the only ones.

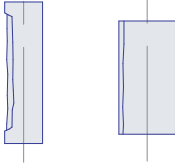
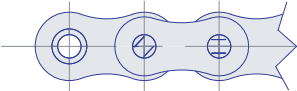
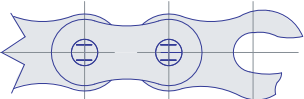
Problem	Possible Causes of Problem	Suggested Remedy
 <p>Pin or Bushing Galling</p>	<ul style="list-style-type: none"> • Overload • Inadequate lubrication 	<ul style="list-style-type: none"> • Properly lubrication • Replace chain when elongation exceeds functional limits
 <p>Turned Pins</p>	<ul style="list-style-type: none"> • Overload • Inadequate lubrication 	<ul style="list-style-type: none"> • Replace chain as soon as possible
<p>Excessive Noise</p>	<ul style="list-style-type: none"> • Too little or too much slack • Chain obstruction • Loose chain guard or bearing 	<ul style="list-style-type: none"> • Adjust centers or take-up • Inspect & remove obstruction • Tighten bolts and check bearings
<p>Chain Vibration</p>	<ul style="list-style-type: none"> • Excessive chain slack • Center distance too long • stiff links 	<ul style="list-style-type: none"> • Adjust chain tensioner • Install idler • Lubricate or replace chain
<p>Wear on inside of link plate and one side of sprocket teeth</p>	<ul style="list-style-type: none"> • Misalignment 	<ul style="list-style-type: none"> • Realign sprockets and shafts • Replace chain and sprockets if necessary
<p>Chain stiffens</p>	<ul style="list-style-type: none"> • Excessive load • Misalignment • Inadequate lubrication • Corrosion 	<ul style="list-style-type: none"> • Replace chain with one of suitable strength • Inspect alignment • Clean and establish correct lubrication • Replace with corrosion resistant chain
<p>Chain Climbs Sprockets</p>	<ul style="list-style-type: none"> • Excessive chain wear • Excessive chain slack • Inadequate lubrication • Sprocket tooth wear 	<ul style="list-style-type: none"> • Replace chain • Install tensioner if necessary • Replace sprocket
 <p>Fractured Plate</p>	<ul style="list-style-type: none"> • Extreme overload 	<ul style="list-style-type: none"> • Inspect the drive to determine the cause of high load • Redesign drive using a higher capacity chain

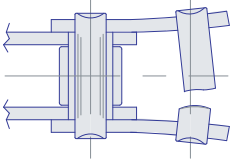
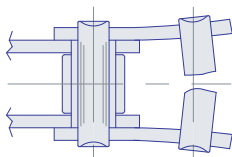
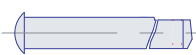
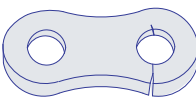
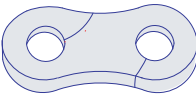
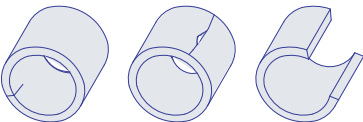
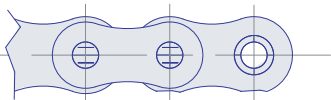
Problem	Possible Causes of Problem	Suggested Remedy
 <p>Broken Pins</p>	<ul style="list-style-type: none"> • Extreme overload 	<ul style="list-style-type: none"> • Inspect the drive to determine the cause of high load • Redesign drive using a higher capacity chain
 <p>Broken Pins(center)</p>	<ul style="list-style-type: none"> • Loading is greater than pins dynamic capacity 	<ul style="list-style-type: none"> • Inspect the drive to determine the cause of high load • Redesign drive using a higher capacity chain
 <p>Broken Offset Link Pins</p>	<ul style="list-style-type: none"> • Overload 	<ul style="list-style-type: none"> • One-pitch offsetlinks are not recommended • Redesign drive using a higher capacity chain
 <p>Fatigue Failure</p>	<ul style="list-style-type: none"> • Loading is greater than chain's dynamic capacity 	<ul style="list-style-type: none"> • Inspect the drive to determine the cause of high load • Redesign drive using a higher capacity chain
 <p>Cracking</p>	<ul style="list-style-type: none"> • Stress corrosion cracking 	<ul style="list-style-type: none"> • Protect the chain from corrosion • Install anti-corrosive chains
 <p>Broken Rollers</p>	<ul style="list-style-type: none"> • Foreign material between chain and sprocket tooth • Fatigue failure 	<ul style="list-style-type: none"> • Redesign chain speed and load • Shield drive from foreign matter
 <p>Worn Plates</p>	<ul style="list-style-type: none"> • Bottom of plates worn due to rubbing on guides. 	<ul style="list-style-type: none"> • Chain should be replaced when wear becomes over 5% of the plates height

SELECTION OF ROLLER CHAIN

It is important to select the most suitable roller chains and sprockets for the job by careful study of power transmission requirements.

The following basic factors should be considered when selecting roller chains for transmission needs through there may be other factors.

ATMOSPHERIC CONSIDERATION

The input power ratings appearing on the pages of 80 to 84, have been worked out under the following conditions.

- 1) To be driven in normal atmosphere of -10° F to 60° C free from ill effect of abrasive dust, corrosive gas, high humidity etc.
- 2) Sprockets should be aligned and mounted on parallel horizontal shafts.
- 3) Recommended method of lubrication and recommended kind of lubricant should be used.
- 4) Should be driven at even load or small load variations.

Power rating of multiple strand chain is not simply calculable by multiplying the power rating of one strand by the number of strand because of uneven load distribution onto each strand. So, multiple strand factor should be used for expected service life.

A service life of 15,000 hrs, can be expected when chain length is 100 pitches and the above conditions are met.

POINT IN SELECTION ROLLER CHAIN AND SPROCKET

The following factors must be taken into consideration in selecting proper chain drive, depending on chain speed-normal or low speed. Also correction factors should be used, fully grasping the conditions of use.

- | | |
|--|---|
| a) Driven machine | e) RPM and diameter of high speed shaft[n1:rpm] |
| b) Type of load: smooth light or heavy shock | f) RPM and diameter of low speed shaft[n2:rpm] |
| c) Source of power | g) Center distance of shaft [m] |
| d) kW to be transmitted [kW0:kW] | h) Chain-driving speed [S:m/min] |

SELECTION PROCEDURE ACCORDING TO CHAIN SPEED

IN CASE OF NORMAL SPEED

S=50 ~ 250m/min

To obtain corrected power kW₁ multiply kW₀ by corrected factor f₁ applied according to condition of use

$$kW_1 = kW_0 \cdot f_1 = kW_0 \cdot f_1 \cdot f_2$$

To obtain chain and high-speed sprocket teeth N₁ use roller chain quick selection chart and power rating chart according to RPM of high speed shaft and corrected power kW₁

N₁

Determine low speed sprocket teeth N₂ from speed ratio R

$$R = n_1/n_2 \\ N_2 = R \cdot N_1$$

See if each sprocket shaft diameter and mounting space satisfy specifications of machinery

* Check

Make special sprocket

Obtain corrected power kW₁ of single strand by referring to multiple strand factor f₂

OK

Finally determined

Economical sprockets for general industrial use are recommended except when special sprockets are made due to unavoidable circumstances.

IN CASE OF LOW SPEED

S=Less than 50m/min.

Divided into two cases depending on chain driving conditions

- 1) For low speed drive with few stops and starts, make the chain selection in a way to satisfy the following formula:
 $T \times f_1 \times f_3$ Max. allowable chain load.
- 2) For low speed drive with frequent stops and starts.
 $T \times f_1 \times f_3 \times f_4$ Ave. ultimate strength.

Select the chain by substituting the values of chain speed and max working load into formulas (1)&(2), after chain selected tentatively in the general way.

N₁ [-] = Number of teeth on small sprocket.

N₂ [-] = Number of teeth on large sprocket.

P [mm] = Chain pitch

S [m/min] = Chain speed

$$= N_1 \cdot P \cdot n_1 / 1000$$

T [kN] = Max. working load.

$$= 60 \times kW_0 / S$$

f₂ : MULTI-STRAND FACTOR

Number of roller chain strands	f ₂
2	1.7
3	2.5
4	3.3
5	3.9
6	4.6
8	6.2
10	7.5

Roller Chain Quick Selection Chart

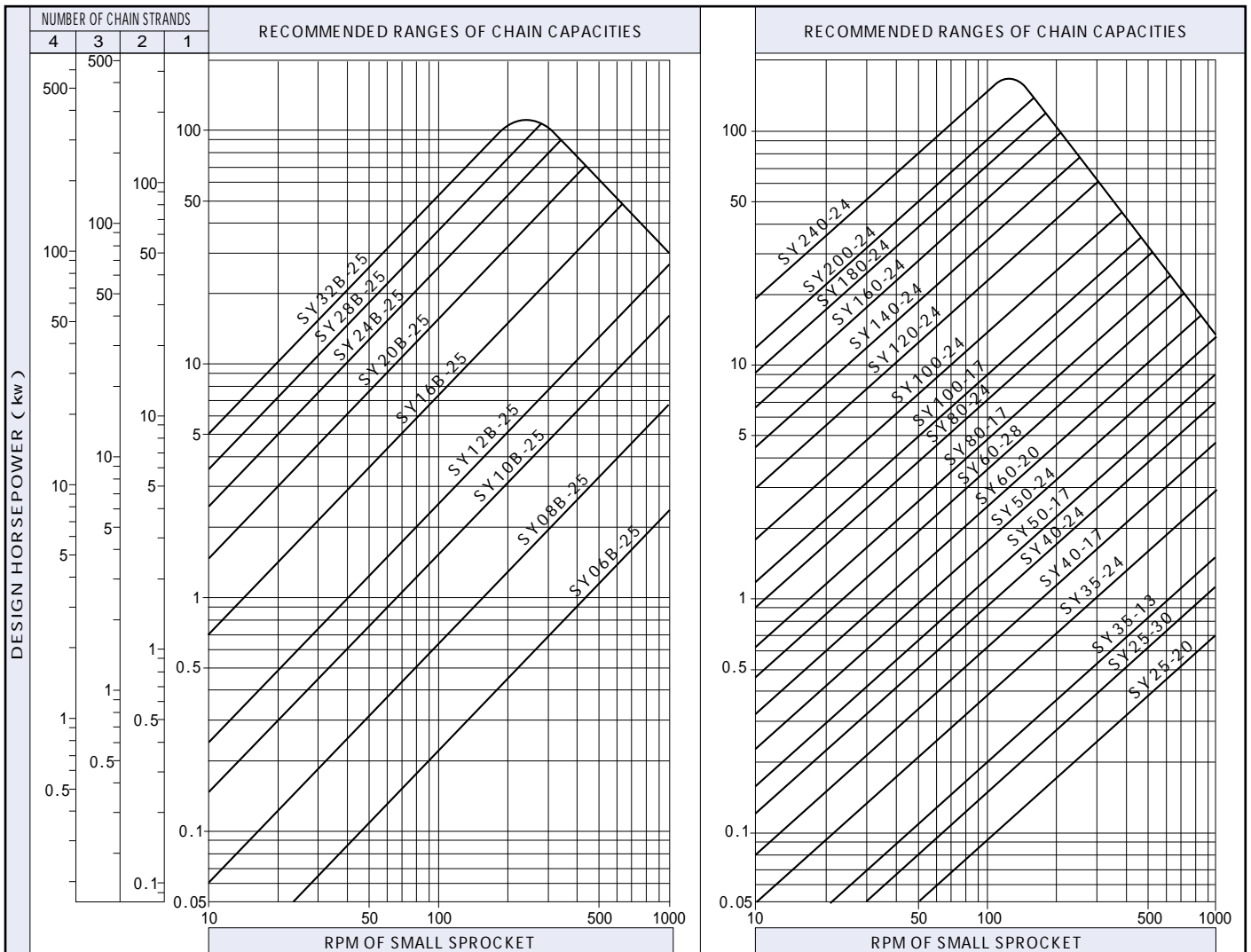

CONCISE SELECTION DATA

SY Chain No.	SY Standard(ANSI)		Each Series				
	Max. Allowable Load	Ave. Ultimate Strength	Ave. Ultimate Strength(kN)				
			E	U	H	HE	HU
35	2.16	10.8					
40	3.63	19.1					
50	6.28	31.9					
60	8.63	43.1	47.1		54.9	53.9	
80	14.7	78.5	79.4	84.3	60.2	93.2	98.1
100	22.6	118	119	127	137	142	145
120	30.4	167	174	186	186	191	196
140	40.2	216	227	245	241	252	255
160	53.0	275	294	314	306	319	324
180	57.9	353		412	373		
200	71.6	451		490	520		
240	98.1	677		726	726		

f1: SERVICE FACTOR

Driven Load Condition	Interval Combustion Engine		Motor or Turbine
	Hydraulic Drive	Mechanical Drive	
Uniform Smooth	1.0	1.2	1.0
Moderate Shock	1.2	1.4	1.3
Heavy Shock	1.4	1.7	1.5

f3: SPEED COEFFICIENT f4: SAFETY FACTOR

Chain Speed	f3	Chain Speed	f4
15m/min.	1.0	25m/min.	7
15 ~ 30	1.2	25 ~ 50	8
30 ~ 50	1.4		

INSTALLATION AND ARRANGEMENT

To design excellent chain drives, chains and sprockets should be properly arranged and installed.

CENTER DISTANCE AND CHAIN LAP

Chain lap on the small sprocket must be at least 120 degrees.

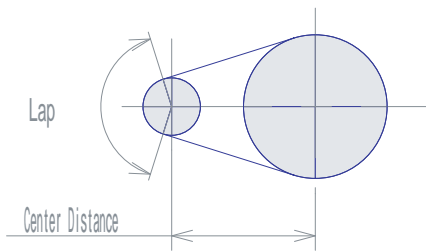

Sprockets can be spaced at any distance as long as their teeth do not touch. Optimum distance is 30 to 50 times of pitch of the chain used except when there is a pulsating load. In case of pulsating drive, distance of less than 20 chain pitches is adequate.

TENSION AND SLACK

Proper amount of chain tension should be maintained. Inadequate tension will step up wear, while excessive sag will result in pulsating impact, stranding and breakage.

Adequate slack is 4 % of the span for normal drives. In the following cases, the slack should be about 2 % of the span.

- 1) Vertical position or near to vertical position.
- 2) Center distance exceeding 1 meter.
- 3) Heavy load application with frequent starts and stops.
- 4) Application with sudden reverse motions.

DRIVE POSITIONS

Horizontal

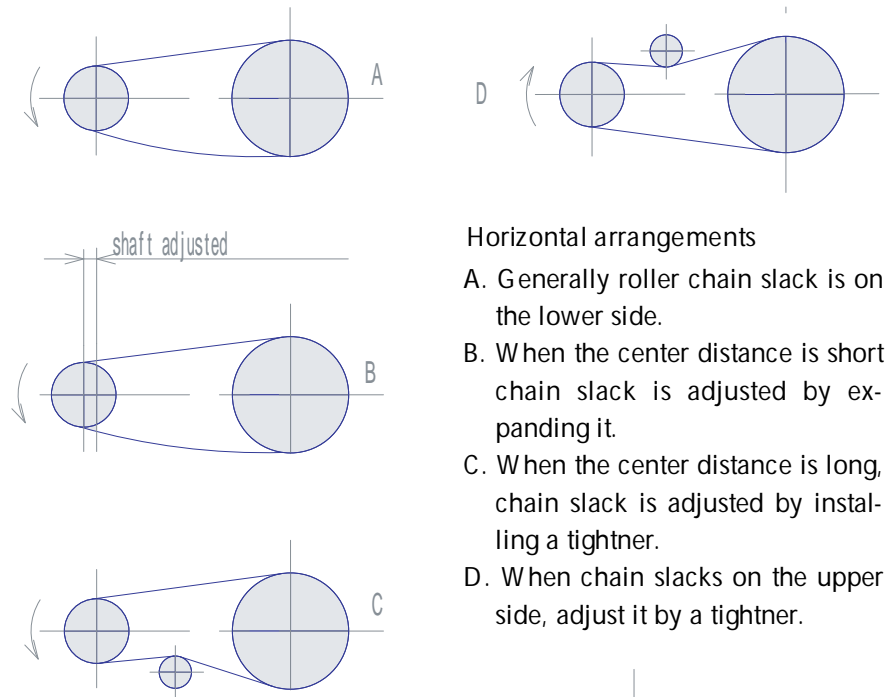

Horizontal arrangements

- A. Generally roller chain slack is on the lower side.
- B. When the center distance is short chain slack is adjusted by expanding it.
- C. When the center distance is long, chain slack is adjusted by installing a tightener.
- D. When chain slacks on the upper side, adjust it by a tightener.

Inclined and Vertical

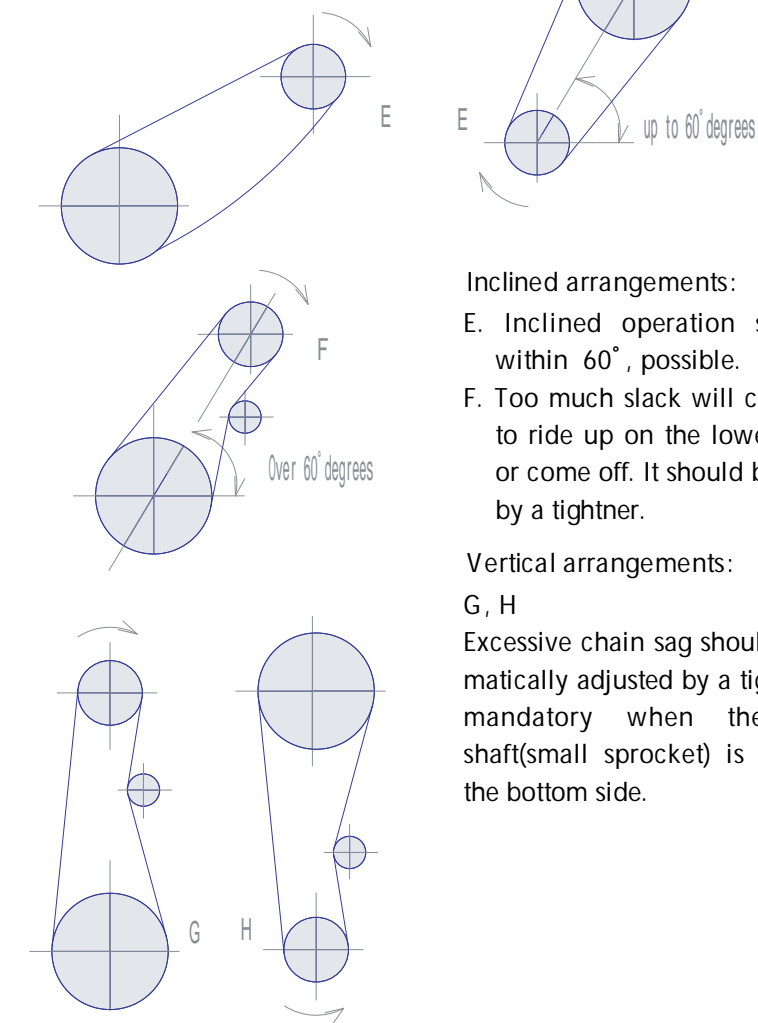

Inclined arrangements:

- E. Inclined operation should be within 60° , possible.
- F. Too much slack will cause chain to ride up on the lower sprocket or come off. It should be adjusted by a tightener.

Vertical arrangements:

- G, H
Excessive chain sag should be automatically adjusted by a tightener. It is mandatory when the driving shaft (small sprocket) is placed on the bottom side.

LUBRICATION

Proper lubrication of roller chains is a very important factor in getting their best possible performance and longer lifetime. No matter how well a transmission system is designed, if it is not properly lubricated, its service life will be shortened.

Abrasion between the pin and bushing causes roller chains to stretch. Therefore, these parts should be well lubricated.



The gap between the pin-link plate and roller-link plate on the slack side of the chain should be filled with lubricant.

The oil forms a film which minimizes wear of the pin and bushing thus increasing the chain service life.

It also reduces noises and cools down the chain running at high speed.

POINTS OF LUBRICATION

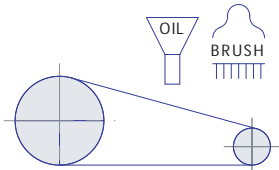
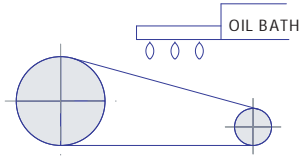
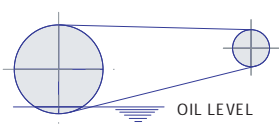
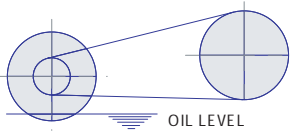
- 1) Fill and change oil periodically.
- 2) Generally, heavy oil and grease are not suitable as a lubricant.
- 3) Avoid mix of oil with another kind or other maker's.
- 4) Adequate lubrication quantity is also essential for a chain's longer service life.

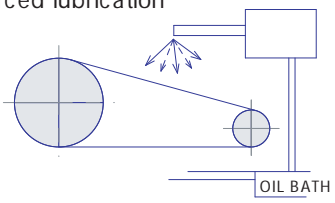
Type	Method	Amount
A	Manual lubrication 	Periodically to keep chain joints from drying
	Dripping lubrication 	Usually 4-20 drops of oil per minute. Excess oil should be reserved in a simple case.
B	Oil bath lubrication 	Effective at medium and low speeds. To be dipped 6 ~ 12 mm.
	Lubrication by slinger disc For large speed ratio 	Effective at rather high speeds. To be dipped 12 ~ 25mm at about 200m/min. circumferential speed of slinger disc.
	Lubrication by slinger disc For small speed ratio 	Case should be cleaned to remove impurities.
C	Forced lubrication 	Effective for heavy load, high power and high speed. Ab 4ltr/min. should be filled without oil shortage or heating up. Closed circulating lubrication system needs a clean tank or case.

SY Chain No.	Temperature[°C]							
	-10	0	40	50	-10	0	40	50
	0	40	50	60	0	40	50	60
Lubrication Type	TYPE A·B				TYPE C			
~SY50	SAE10	SAE20	SAE30	SAE50	SAE10	SAE20	SAE30	SAE40
SY60~SY80	20	30	40	50	10	20	30	40
SY100	20	30	40	50	20	30	40	50
SY120~	30	40	50	50	20	30	40	50



If misselected, misinstalled and missafe-guard Chain will break and serious injury or property damage can result. Please read an instruction manual carefully before installation.

Roller Chain Application Information

Please select the chain (compare with Technical Data) when you use.

If the chain abused through improper installation, operating or maintenance procedures, failure can lead to personal injury or property damage.

Ultimate Tensile Strength

Ultimate tensile strength is the one time pull required to break the chain therefore these are not the allowable working load.

Safety factor must be considered when selecting roller chain.

A roller chain should never be loaded above 50% of Ultimate strength for even one cycle. When to use a multiple-strand roller chain, please consider the multiple-strand factor.

Guarding

The chain can break in normal service due to the effects of wear, fatigue or unexpected overloads. Therefore a roller chain drive should have adequate guarding to prevent personal injury or property damage.

Connecting Link

When a slip-fit connecting link coverside for ease of assembly is used, a chain's working capacity is reduced as much as 20% on some models. SUGIYAMA CHAIN offered New Connecting Links with slip-fit coverside as strong as the base chain. Recommend this New Connecting Link to use.

Offset Link

One-pitch offset links are very handy, pin and offset linkplates have to be slip-fitted.

It's allowable working load is approximately 30% less.

Therefore one-pitch offset links are not recommended especially frequent, impact load and high speed driving.

The two-pitch offset link is combination of a roller link and an offset link connected with a riveted pin.

So two-pitch offset link can be used in high speed or heavy duty applications.

Cotter Pin, Spring Clip

Keep angle 90° approx. to spread out prongs of cotter pin. Do not reuse the cotter and do not use the commercial cotters on the market.

Be sure to insert spring clip properly into and seat in the groove on the end of Pin after installation of Connecting Link cover plate onto pins, and do not spring one leg of the clip over the pin end to avoid breakdown of the leg.

Do not spread out clip's legs too much to prevent falling spring clip off and unexpected accident.

Install spring clips with solid end pointing in the direction of chain travel.

Rust Corrosion

If a chain is corroded, its capacity is reduced.

If corrosion is severe, the link plates may crack even though the chain is not under load.

In view this, carbon steel chain should not be exposed to corrosive conditions, acid fumes, salt spray sea water.

Chain corrosion from normal atmospheric conditions may be minimized by proper lubrication.

CAUTION

- 1) Always lock out machinery power switch before attempting removal , installation, or any servicing of chain
- 2) Wear eye and face protection when grinding, driving, or disassembling pins.
- 3) Always wear gloves ,protective clothing and safety shoes with steel toe when working with chains.
- 4) Make absolutely sure that chain is properly supported to prevent uncontrolled movement of chain and parts.
- 5) Chain pressers and breaking tools are recommended to be in good working order and to be used according to instructions.
- 6) Avoid plating or welding assembled chains or components.
- 7) Never repair damaged chains by replacing only the component parts.
- 8) Damaged chain may be yielded and therefore should not be reworked.

Maintenance Check List

Inspect on regularly scheduled basis for worn ,damaged or broken parts ,possible interference by other systems components, and proper lubrication.

Normal maintenance procedures can prevent most of the conditions described below.

Carefully inspect roller chain drives on the same schedule as associated equipment.

Sprocket Misalignment

Wear on the sides of sprocket teeth generally indicates improper installation of sprockets and/or shafts. If shafts are out of parallel or not in the same plane, non-symmetrical wear will appear on sprockets or chain rollers.

After proper alignment is made retighten set screws in sprocket hubs.

Chain wear and Elongation

Normal wear will cause some increase in chain length. However,if a sudden increase in elongation occurs , look for severe wear on the tips of sprocket teeth. This may be caused by any of the following : excessive loading or shock loading , displacement and/or wear in bearings,displacement of take-up ,or under-designed drives.

Excessive elongation may be an indication that chain and/or sprockets should be replaced.

Before replacing chain or sprockets ,recalculate initial drive design. Check chain tension if there is too much accumulated slack in the drive.

Broken Chain Parts

Generally caused by an overloaded drive ; extreme misalignment ; excessive elongation causing chain to jump sprocket teeth; heavy shock; improper drive design geometry; foreign objects.

Recalculate initial drive design and make necessary correction .Inspect sprockets and shafts for proper alignment or looseness.

Link Plate Wear

Wear on inside of the link plates and on one side of sprocket teeth may be caused by a misalignment misalignment of sprockets.

Realign sprockets and shafts. Inspect chain carefully ,readjust chain properly or replace.

Removing Chain

Turn the drive until a connecting link is fully engaged with one of the sprockets so as to relieve the tension on the connecting pin.

The connecting link may then be removed.

Excessive Noise

Can be caused by broken links and chain rollers,extreme misalignment, elongation, chain jumping sprocket teeth , loose sprockets, broken teeth ,accumulation of dirt packed into the chain or sprockets teeth, interference by foreign objects, contacting a fixed object

Check for worn broken or missing parts. Check alignment of shafts and/or sprockets.

Lubrication

On slow speed drives, where manual lubrication is used, if drip lubrication is used check for adequate oil flow and proper application to the chain.

With bath or pump lubrication, check oil level and add oil if needed. Check oil for contamination and change oil if needed. If pump lubrication is used, check each orifice to be sure it is clear and is directing oil onto the chain properly.

Recommended Replacement

Measure the chain wear elongation and if elongation exceeds functional limits or is greater than 3% (0.36 inch in one foot) replace the entire chain.

Do not connect a new section of chain to a worn chain because it may run roughly and damage the drive. Do not continue to run a chain worn beyond

3% elongation because the chain will not engage the sprockets properly and it may damage the sprockets.

Cutting Riveted Chain

The two pins of a pin link must be driven out of the link plate. Strike the pins alternately to avoid distortion of the roller link plates as well as the plates of the adjacent links.

Chain cutting tools can also be used. Follow their instruction carefully.

Inserting New Links

Insert only on new roller chain. Pitch variance between a new link and an old link, especially one which is elongated due to wear, will cause shock when the new link engages the sprockets.

Installing New Chain

Chain and/or related parts should be visually inspected for damage, which could have occurred during shipping prior to installation.

Never install new chain on worn sprockets as this will permanently damage chain. With new chain and sprockets installed , check for proper and sprockets installed, check for proper tension and alignment.

MAXIMUM KILLOWATT RATING OF 120

Table with 19 columns (10-1600) and 18 rows (9-45). Header includes 'Maximum R.P.M.-Small Sprocket' and 'Lubrication System' with sub-sections A, B, and C.

MAXIMUM KILLOWATT RATING OF 140

Table with 19 columns (10-1200) and 18 rows (9-45). Header includes 'Maximum R.P.M.-Small Sprocket' and 'Lubrication System' with sub-sections A, B, and C.

MAXIMUM KILLOWATT RATING OF 160

Table with 20 columns (10-900) and 18 rows (9-45). Header includes 'Maximum R.P.M.-Small Sprocket' and 'Lubrication System' with sub-sections A, B, and C.

Chain No.	Page	Type of Chain	Chain No.	Page	Type of Chain	Chain No.	Page	Type of Chain
06B	10	BS	40 -NP	43	Nickel Plated	120	19	Roller Chain
-F	22	Straight	-SB	45	Side Bow	-E	26	Heavy Duty
-SS	36	Stainless	-SL	49	Self-Lube	-F	23	Straight
-NP	42	Nickel Plated	-SLR	52	"	-H	24	Heavy Duty
08B	11	BS	-SS	36	Stainless	120 -HE	28	"
-F	22	Straight	HB 40 -SL	49	Oilless Hollow	-SL	49	Self-Lube
-SS	36	Stainless	40AB -MF	57	Maintenance Free	-SS	36	Stainless
-NP	42	Nickel Plated	40B -ECO	15	Economical Style	-DC	32	Double cap.
-SLR	51	Self-Lube	48B -ECO	15	Economical Style	-SUPER	30	Heavy Duty
10B	11	BS	50	17	Roller Chain	-SUPER-H	30	"
-F	22	Straight	-F	23	Straight	140	19	Roller Chain
-SS	36	Stainless	-HP	46	Hollow-Pin	-E	27	Heavy Duty
-NP	42	Nickel Plated	-HPSS	47	Hollow-Pin	-F	23	Straight
-SLR	51	Self-Lube	-NP	43	Nickel Plated	-H	24	Heavy Duty
12B	12	BS	-SB	45	Side Bow	-HE	29	"
-F	22	Straight	-SL	49	Self-Lube	-SL	49	"
-SS	36	Stainless	-SLR	52	"	-SS	36	Stainless
-NP	42	Nickel Plated	-SS	36	Stainless	-DC	32	Double cap.
-SLR	51	Self-Lube	48AB -MF	57	Maintenance Free	-SUPER	30	Heavy Duty
16A -MF	57	Maintenance Free	HB 50 -SL	49	Oilless Hollow	-SUPER-H	30	"
16B	12	BS	60	17	Roller Chain	160	20	Roller Chain
-MF	57	Maintenance Free	-E	26	Heavy Duty	-E	27	Heavy Duty
-F	22	Straight	-F	23	Straight	-F	23	Straight
-SS	36	Stainless	-H	24	Heavy Duty	-H	24	Heavy Duty
-DC	32	Double cap.	-HP	46	Hollow-Pin	-HE	29	"
-NP	42	Nickel Plated	-HPSS	47	Hollow-Pin	-SL	49	"
-SLR	51	Self-Lube	-NP	43	Nickel Plated	-SS	36	Stainless
-ECO	15	Economical Style	-SB	45	Side Bow	-DC	32	Double cap.
20AB -MF	57	Maintenance Free	-SL	49	Self-Lube	-SUPER	30	Heavy Duty
20B	13	BS	-SLR	52	"	-SUPER-H	30	"
-F	22	Straight	-SS	36	Stainless	180	20	Roller Chain
-DC	32	Double cap.	HB 60 -SL	49	Oilless Hollow	-E	27	Heavy Duty
-NP	42	Nickel Plated	80	18	Roller Chain	-H	24	"
-SLR	51	Self-Lube	-E	26	Heavy Duty	-DC	32	Double cap.
-ECO	15	Economical Style	-F	23	Straight	200	21	Roller Chain
24A -MF	57	Maintenance Free	-H	24	Heavy Duty	-E	27	Heavy Duty
24B	13	BS	-HE	28	"	-F	23	Straight
-MF	57	Maintenance Free	-HP	46	Hollow-Pin	-H	24	Heavy Duty
-F	22	Straight	-HPSS	47	Hollow-Pin	-HE	29	"
-DC	32	Double cap.	-NP	43	Nickel Plated	-DC	32	Double cap.
-SLR	51	Self-Lube	-SB	45	Side Bow	-SUPER	30	Heavy Duty
-ECO	15	Economical Style	-SL	49	Self-Lube	240	21	Roller Chain
28A -MF	57	Maintenance Free	-SLR	52	"	-E	27	Heavy Duty
28B	14	BS	-SS	36	Stainless	-F	23	Straight
-MF	57	Maintenance Free	-DC	32	Double cap.	-H	24	Heavy Duty
-F	22	Straight	-SUPER	30	Heavy Duty	-HE	29	"
-DC	32	Double cap.	-SUPER-H	30	"	-DC	32	Double cap.
-SLR	51	Self-Lube	HB 80 -SL	49	Oilless Hollow	-SUPER	30	Heavy Duty
-ECO	15	Economical Style	81X	72	Engineering	251S	33	"
32AB -MF	57	Maintenance Free	-H	72	"	264S	33	"
32B	14	BS	-HS	72	"	AL 422	58	Leaf Chain
-F	22	Straight	100	18	Roller Chain	BL 422	59	"
-DC	32	Double cap.	-E	26	Heavy Duty	BL 423	59	"
-SLR	51	Self-Lube	-F	23	Straight	BL 434	59	"
-ECO	15	Economical Style	-H	24	Heavy Duty	AL 444	58	"
35	16	Rollerless	-HE	28	"	BL 444	59	"
-F	23	Straight	-NP	43	Nickel Plated	BL 446	59	"
-NP	43	Nickel Plated	-SL	49	Self-Lube	AL 466	58	"
-SS	36	Stainless	-SLR	52	"	BL 466	59	"
40	16	Roller Chain	-SS	36	Stainless	AL 522	58	"
-F	23	Straight	-DC	32	Double cap.	BL 522	59	"
-HP	46	Hollow-Pin	-SUPER	30	Heavy Duty	BL 523	59	"
-HPSS	47	Hollow-Pin	-SUPER-H	30	Heavy Duty	BL 534	59	"

TECHNICAL INFORMATION

Chain No.	Page	Type of Chain	Chain No.	Page	Type of Chain	Chain No.	Page	Type of Chain
AL544	58	Leaf Chain	AL1644	58	Leaf Chain	HB2060 -SL	55	Oilless Hollow
BL544	59	"	BL1644	59	"	C2060H	35	Double Pitch
BL546	59	"	LL1644	60	"	-NP	44	Nickel Plated
AL566	58	"	BL1646	59	"	-SLR	54	Self-Lube
BL566	59	"	AL1666	58	"	-SS	37	Stainless
AL622	58	"	BL1666	59	"	-DC	33	Double Cap.
BL622	59	"	LL1666	60	"	C2062 -HP	46	Hollow-Pin
BL623	59	"	BL2022	59	"	-HPSS	47	Hollow-Pin
BL634	59	"	LL2022	60	"	-SB	45	Side Bow
AL644	58	"	BL2023	59	"	-SL	50	Self-Lube
BL644	59	"	BL2034	59	"	HR2062 -SL	55	Oilless Hollow
BL646	59	"	A2040	34	Double Pitch	C2062H	35	Double Pitch
AL666	58	"	-NP	44	Nickel Plated	-NP	44	Nickel Plated
BL666	59	"	-SL	50	Self-Lube	-SS	37	Stainless
AL822	58	"	-SS	37	Stainless	LL2066	60	"
BL822	59	"	C2040	35	Double Pitch	A2080	34	Double Pitch
LL0822	60	"	-HP	46	Hollow-Pin	-NP	44	Nickel Plated
BL823	59	"	-HPSS	47	Hollow-Pin	-SS	37	Stainless
BL834	59	"	-NP	44	Nickel Plated	C2080 -HP	46	Hollow Pin
AL844	58	"	-SB	45	Side Bow	-HPSS	47	Hollow-Pin
BL844	59	"	-SL	50	Self-Lube	-SL	50	Self-Lube
LL0844	60	"	-SLR	54	"	HB2080 -SL	55	Oilless Hollow
BL846	59	"	-SS	37	Stainless	C2080H	35	Double Pitch
AL866	58	"	-DC	33	Double Cap.	-NP	44	Nickel Plated
BL866	59	"	HB2040 -SL	55	Oilless Hollow	-SLR	54	Self-Lube
LL0866	60	"	C2042	35	Double Pitch	-SS	37	Stainless
AL1022	58	"	-HP	46	Hollow-Pin	-DC	33	Double Cap.
BL1022	59	"	-HPSS	47	Hollow-Pin	C2082 -HP	46	Hollow Pin
LL1022	60	"	-NP	44	Nickel Plated	-HPSS	47	Hollow-Pin
BL1023	59	"	-SB	45	Side Bow	-SL	50	Self-Lube
BL1034	59	"	-SL	50	Self-Lube	HR2082 -SL	55	Oilless Hollow
AL1044	58	"	-SS	37	Stainless	C2082H	35	Double Pitch
BL1044	59	"	HR2042 -SL	55	Oilless Hollow	-NP	44	Nickel Plated
LL1044	60	"	LL2044	60	Leaf Chain	-SS	37	Stainless
BL1046	59	"	A2050	34	Double Pitch	C2100H	35	Double Pitch
AL1066	58	"	-NP	44	Nickel Plated	C2100H -NP	44	Nickel Plated
BL1066	59	"	-SL	50	Self-Lube	-SLR	54	Self-Lube
LL1066	60	"	-SS	37	Stainless	-SS	37	Stainless
AL1222	58	"	C2050	35	Double Pitch	-DC	33	Double Cap.
BL1222	59	"	-HP	46	Hollow-Pin	C2102H	35	Double Pitch
LL1222	60	"	-HPSS	47	Hollow-Pin	-NP	44	Nickel Plated
BL1223	59	"	-NP	44	Nickel Plated	-SS	37	Stainless
BL1234	59	"	-SB	45	Side Bow	C2120H	35	Double Pitch
AL1244	58	"	-SL	50	Self-Lube	-SS	37	Stainless
BL1244	59	"	-SLR	54	"	-DC	33	Double Cap.
LL1244	60	"	-SS	37	Stainless	C2122H	35	Double Pitch
BL1246	59	"	-DC	33	Double Cap.	-SS	37	Stainless
AL1266	58	"	HB2050 -SL	55	Oilless Hollow	C2160H	35	Double Pitch
BL1266	59	"	C2052	35	Double Pitch	-SS	37	Stainless
LL1266	60	"	-HP	46	Hollow-Pin	-DC	33	Double Cap.
AL1422	58	"	-HPSS	47	Hollow-Pin	C2162H	35	Double Pitch
BL1422	59	"	-NP	44	Nickel Plated	-SS	37	Stainless
BL1423	59	"	-SB	45	Side Bow	LL2422	60	Leaf Chain
BL1434	59	"	-SL	50	Self-Lube	LL2444	60	"
AL1444	58	"	-SS	37	Stainless	LL2466	60	"
BL1444	59	"	A2060	34	Double Pitch	LL2822	60	"
BL1446	59	"	-NP	44	Nickel Plated	LL2844	60	"
AL1466	58	"	-SL	50	Self-Lube	LL2866	60	"
AL1622	58	"	-SS	37	Stainless	LL3222	60	"
BL1622	59	"	C2060 -HP	46	Hollow-Pin	LL3244	60	"
LL1622	60	"	-HPSS	47	Hollow-Pin	LL3266	60	"
BL1623	59	"	C2060 -SB	45	Side Bow			
BL1634	59	"	-SL	50	Self-Lube			